

Instructions for Parts Books

The heading at the top of the page will be the same for the picture of the parts at it is for the page with the part numbers.

Definition of column headings on part number pages:

REF.No → The number referring to the part on the picture page of the parts book.

Part No. → The number assigned to this part at the time of printing the parts book.

Description → Discription of part.

Q'ty → Quantity of part used on that page.

S.No. → Serial number range of the equipment that this part will fit.

>= Your serial number should be greater than or equal to the number shown.

<= Your serial number should be lesser than or equal to the serial number shown.

I/C → Interchangeability of part shown.

↔ The part shown will work for the older and later serial number.

The part shown is not interchangeable with the other serial number.

← new for old

→ old for new

Remarks → Notes about this particulart part. Sometimes this may say except [FR] or [CA]

Note about Country Codes:

The parts books we use in the United States of America may also contain information about a part that would be different in another country. It is important that you are aware of the country codes in some instances.

Symbol	Country
A	United States of America
CA	Canada
FR	France
GR	Greece
PO	Portugal
AU	Australia

If the remarks column says for example EXCEPT [FR] this part works in all countries except France. That means it will work here in the USA.

ALL PRODUCT INDEX
L355SS

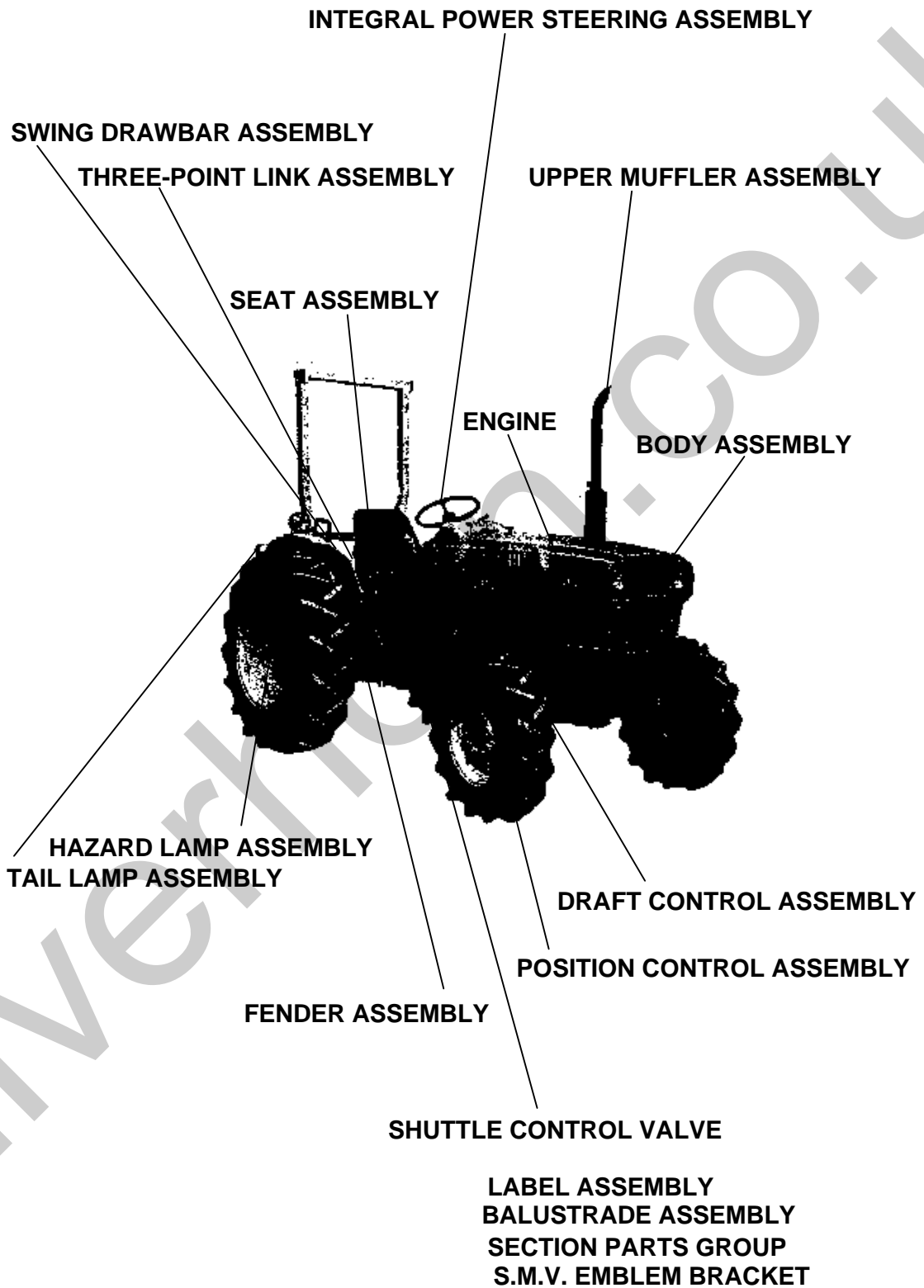

Item	Part No.	Description	Book	
ENGINE	01001	CRANKCASE	100K0347	
	01002	OIL PAN	100K0347	
	01003	CYLINDER HEAD	100K0347	
	01004	GEAR CASE	100K0347	
	01005	MAIN BEARING CASE	100K0347	
	01006	AIR CLEANER	100K0347	
	01007	EXHAUST MANIFOLD	100K0347	
	01008	VALVE,ROCKER ARM	100K0347	
	01009	HEAD COVER	100K0347	
	01010	CAMSHAFT	100K0347	
	01011	PISTON,CRANKSHAFT	100K0347	
	01012	FLYWHEEL	100K0347	
	01013	STARTER SECTION PARTS	100K0347	
	01014	FUEL CAMSHAFT	100K0347	
	01015	GOVERNOR	100K0347	
	01016	SPEED CONTROL PLATE	100K0347	
	01017	ENGINE STOP LEVER	100K0347	
	01018	DYNAMO	100K0347	
	01019	DYNAMO SECTION PARTS	100K0347	
	01020	RADIATOR	100K0347	
	01021	WATER PUMP	100K0347	
	01022	INJECTION PUMP	100K0347	
	01023	INJECTION PUMP SECTION PARTS	100K0347	
	01024	NOZZLE HOLDER	100K0347	
	01025	NOZZLE HOLDER SECTION PARTS	100K0347	
	01026	OIL HYDRAULIC PUMP	100K0347	
	01027	OIL HYDRAULIC PUMP SECTION PARTS	100K0347	
	BODY ASSEMBLY	01028	AIR CLEANER SUPPORT	100K0347
		01029	FLYWHEEL HOUSING	100K0347
		01030	CLUTCH HOUSING	100K0347
		01031	OIL HYDRAULIC MANIFOLD	100K0347
		01032	CLUTCH SHAFT UPPER	100K0347
		01033	CLUTCH SHAFT LOWER	100K0347
		01034	REVERSE SHAFT	100K0347
		01035	CLUTCH	100K0347
		01036	CLUTCH PEDAL	100K0347
		01037	HAND ACCELERATOR	100K0347
		01038	HOOD 1	100K0347
		01039	HOOD 2	100K0347
		01040	TRANSMISSION CASE	100K0347
		01041	MAIN SHAFT	100K0347
		01042	COUNTER SHAFT	100K0347
		01043	PTO COUNTER SHAFT	100K0347
		01044	SPIRAL BEVEL PINION	100K0347
		01045	POWER TAKE-OFF SHAFT	100K0347
		01046	MAIN SHIFT LEVER	100K0347
		01047	MAIN SHIFT FORK	100K0347
01048		HI-LO GEAR SHIFT LEVER	100K0347	
01049		PTO GEAR SHIFT LEVER	100K0347	
01050		SHUTTLE LEVER	100K0347	
01051		DIFFERENTIAL SYSTEM	100K0347	
01052		DIFF LOCK PEDAL	100K0347	
01053		DIFF YOKE SHAFT	100K0347	
01054		REAR AXLE	100K0347	
01055		AXLE CASE	100K0347	
01056		BRAKE	100K0347	
01057		BRAKE PEDAL	100K0347	

Item	Part No.	Description	Book	
BODY ASSEMBLY	01058	STEP	100K0347	
	01059	PANEL	100K0347	
	01060	HOUR METER AND SWITCH	100K0347	
	01061	REGULATOR	100K0347	
	01062	BATTERY	100K0347	
	01063	HEAD LAMP	100K0347	
	01064	WIRING DIAGRAM	100K0347	
	01065	FUEL FILTER	100K0347	
	01066	FUEL FILTER SECTION PARTS	100K0347	
	01067	OIL HYDRAULIC SYSTEM	100K0347	
	01068	CONTROL VALVE SECTION PARTS	100K0347	
	01069	RELIEF VALVE SECTION PARTS	100K0347	
	01070	CONTROL LEVER	100K0347	
	01071	LEVER GUIDE	100K0347	
	01072	OIL HYDRAULIC CYLINDER	100K0347	
	01073	OIL HYDRAULIC CYLINDER COVER	100K0347	
	01074	LIFT ARM	100K0347	
	01075	OIL HYDRAULIC PIPING	100K0347	
	01076	FRONT DIFF GEAR CASE	100K0347	
	01077	FRONT DIFF CASE	100K0347	
	01078	FRONT AXLE SUPPORT	100K0347	
	01079	AXLE CASE	100K0347	
	01080	BEVEL GEAR SHAFT	100K0347	
	01081	FRONT AXLE	100K0347	
	01082	TIE ROD	100K0347	
	01083	FRONT AXLE BRACKET	100K0347	
	01084	CENTER PIN	100K0347	
	01085	PROPELLER SHAFT	100K0347	
	01086	DRIVE CASE	100K0347	
	01087	DRIVE SHAFT	100K0347	
	THREE-POINT LINK ASSEMBLY	01088	3-POINT LINK 1	100K0347
		01089	3-POINT LINK 2	100K0347
	INTEGRAL POWER STEERING ASSEMBLY	01090	POWER STEERING	100K0347
	01091	OIL TANK	100K0347	
	01092	FUEL TANK	100K0347	
SWING DRAWBAR ASSEMBLY	01093	SWING DRAWBAR	100K0347	
TAIL LAMP ASSEMBLY	01094	TAIL LAMP	100K0347	
HAZARD LAMP ASSEMBLY	01095	HAZARD LAMP	100K0347	
LABEL ASSEMBLY	01096	LABEL	100K0347	
BALUSTRADO ASSEMBLY	01097	BALUSTRADO	100K0347	
SEAT ASSEMBLY	01098	SEAT	100K0347	
S.M.V. EMBLEM BRACKET	01099	S.M.V. EMBLEM BRACKET	100K0347	
FENDER ASSEMBLY	01100	FENDER	100K0347	
SHUTTLE CONTROL VALVE	01101	CONTROL VALVE	100K0347	
	01102	CONTROL VALVE SECTION PARTS 1	100K0347	
	01103	CONTROL VALVE SECTION PARTS 2	100K0347	
UPPER MUFFLER ASSEMBLY	01104	UPPER MUFFLER	100K0347	
POSITION CONTROL ASSEMBLY	01105	TOP LINK HOLDER	100K0347	
DRAFT CONTROL ASSEMBLY	01106	DRAFT CONTROL VALVE	100K0347	
	01107	DRAFT CONTROL VALVE SECTION PARTS	100K0347	
	01108	TOP LINK BRACKET	100K0347	
SECTION PARTS GROUP	01109	VALVE, FLOW PRIORITY	100K0347	
	01110	INTEGRAL TYPE POWER STEERING	100K0347	

CRANKCASE

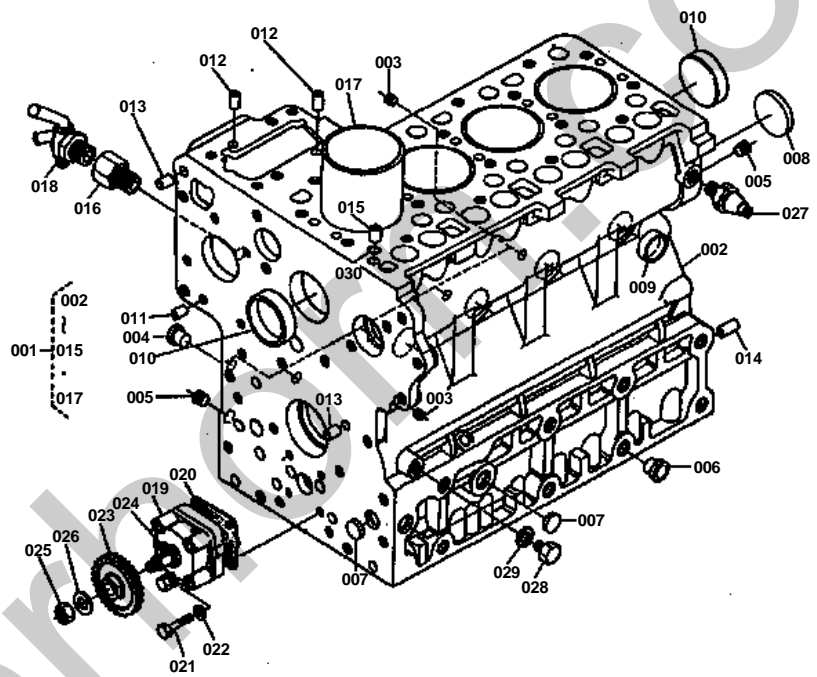



CRANKCASE

↔ Interchangeable; ≠ not interchangeable; ← new for old; → old for new

REF.No	Part No.	Description	Q'ty	S.No.	I/C	REMARKS	Weight (kgf)	Weight (lb)
001	15424-01010	ASSY CRANKCASE	1				54.5	119.9
002	99999-99999	BLANK	0			ORDER BY REF.No.001	0	0
003	15521-96020	PLUG	6				0.003	0.0066
004	34150-27580	PLUG	1				0.001	0.0022
005	15521-96030	PLUG	2				0.007	0.0154
006	32210-27580	PLUG	19				0.001	0.0022
007	06311-75018	PLUG,EXPANSION	3				0.004	0.0088
008	06311-75045	PLUG,EXPANSION	1				0.026	0.0572
009	15221-03380	CAP,SEALING	6				0.017	0.0374
010	15221-03390	CAP,SEALING	2				0.03	0.066
011	05012-00408	PIN,STRAIGHT	2				0.001	0.0022
012	05012-00609	PIN,STRAIGHT	2				0.003	0.0066
013	05012-00612	PIN,STRAIGHT	2				0.003	0.0066
014	05012-01018	PIN,STRAIGHT	3				0.012	0.0264
015	15221-33650	PIN,PIPE	1				0.004	0.0088
016	15291-73160	JOINT,DRAIN COCK	1				0.04	0.088
017	15201-02310	LINER,CYLINDER	4				0.57	1.254
018	15575-73100	COCK,DRAIN	1				0.065	0.143
019	15471-35010	ASSY PUMP,OIL	1				0	0
020	15221-35150	GASKET,OIL PUMP	1				0	0
021	01053-50650	BOLT	4				0.011	0.0242
022	04512-50060	WASHER,SPRING	4				0	0
023	19202-35660	GEAR,OIL PUMP DRIVE	1				0.23	0.506
024	05712-00410	KEY,FEATHER	1				0.001	0.0022
025	15221-35680	NUT	1				0	0
026	15221-35670	WASHER	1				0.005	0.011
027	15221-39010	SWITCH,OIL	1				0	0
028	15221-33610	PLUG	1				0.009	0.0198
029	15021-33660	GASKET	1				0.001	0.0022
030	15221-33700	O RING	1				0.001	0.0022

OIL PAN

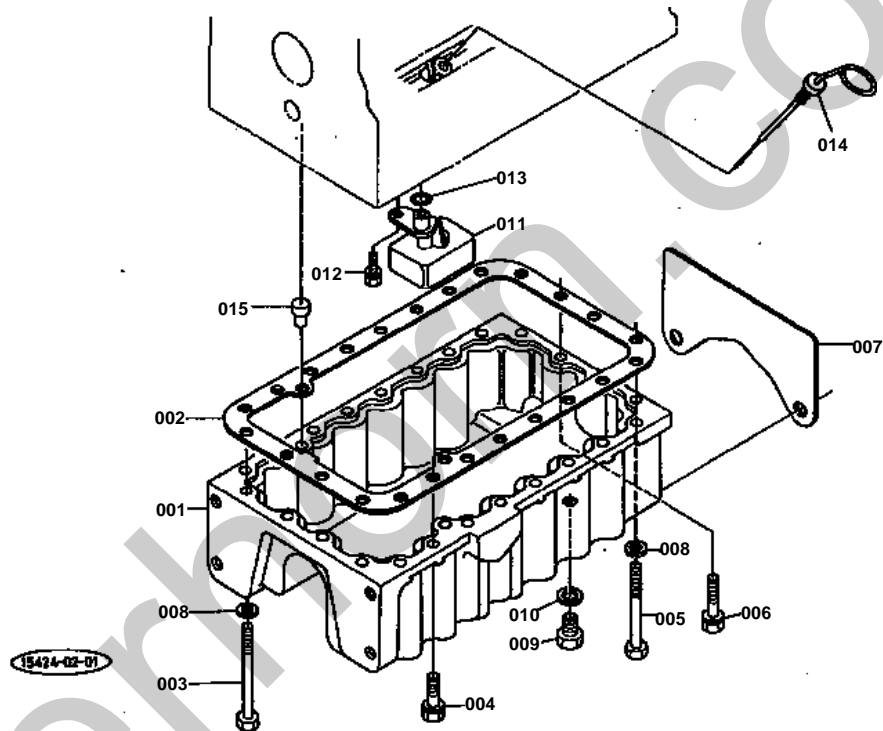



OIL PAN

↔ Interchangeable; ≠ not interchangeable; ← new for old; → old for new

REF.No	Part No.	Description	Q'ty	S.No.	I/C	REMARKS	Weight (kgf)	Weight (lb)
001	15415-01610	OIL PAN	1				15.4	33.88
002	15401-01620	GASKET,OIL PAN	1				0	0
003	15411-91010	BOLT	4				0	0
004	01133-51035	BOLT	16				0.03	0.066
005	15415-91010	BOLT	2				0.075	0.165
006	01133-51050	BOLT	2				0.035	0.077
007	15415-04690	SHIM	2				0.03	0.066
008	04512-50100	WASHER	6				0	0
009	15221-33750	PLUG	2				0.032	0.0704
010	15109-33660	GASKET	2				0.001	0.0022
011	15411-32110	FILTER,OIL 1	1				0.24	0.528
012	01123-50816	BOLT	1				0.011	0.0242
013	04811-00160	O RING	1				0.001	0.0022
014	19222-36410	GAUGE,OIL	1				0.04	0.088
015	15411-94510	PIN	2				0.01	0.022

CYLINDER HEAD

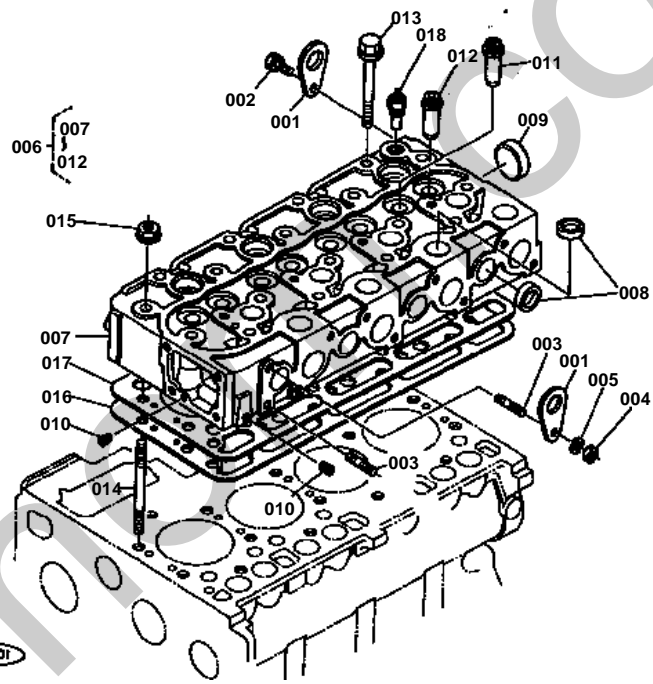



CYLINDER HEAD

↔ Interchangeable; ≠ not interchangeable; ← new for old; → old for new

REF.No	Part No.	Description	Q'ty	S.No.	I/C	REMARKS	Weight (kgf)	Weight (lb)
001	15221-01750	HOOK,ENGINE	2				0.04	0.088
002	01123-50816	BOLT	1				0.011	0.0242
003	15471-91530	STUD	2				0.01	0.022
004	02156-50080	NUT	1				0.004	0.0088
005	04512-50080	WASHER,SPRING	1				0.001	0.0022
006	15422-03040	ASSY CYLINDER HEAD	1				0	0
007	99999-99999	BLANK	0			ORDER BY REF.No.006	0	0
008	15221-03370	CAP,SEALING	12				0.01	0.022
009	15221-03490	CAP,SEALING	1				0.02	0.044
010	15261-96010	PLUG	2				0.002	0.0044
011	15221-13580	GUIDE,VALVE	4				0	0
012	15601-13560	GUIDE,EXHAUST VALVE	4				0	0
013	19202-03450	BOLT,CYLINDER HEAD	16				0.065	0.143
014	19202-03410	STUD,CYLINDER HEAD	2				0.065	0.143
015	19202-03510	NUT,CYLINDER HEAD	2				0.012	0.0264
016	15421-03310	GASKET,CYLINDER HEAD	1				0	0
017	15421-03320	SHIM,CYLINDER HEAD G	1				0.07	0.154
018	33400-75250	SWITCH,THERMOMETER	1				0.033	0.0726

GEAR CASE

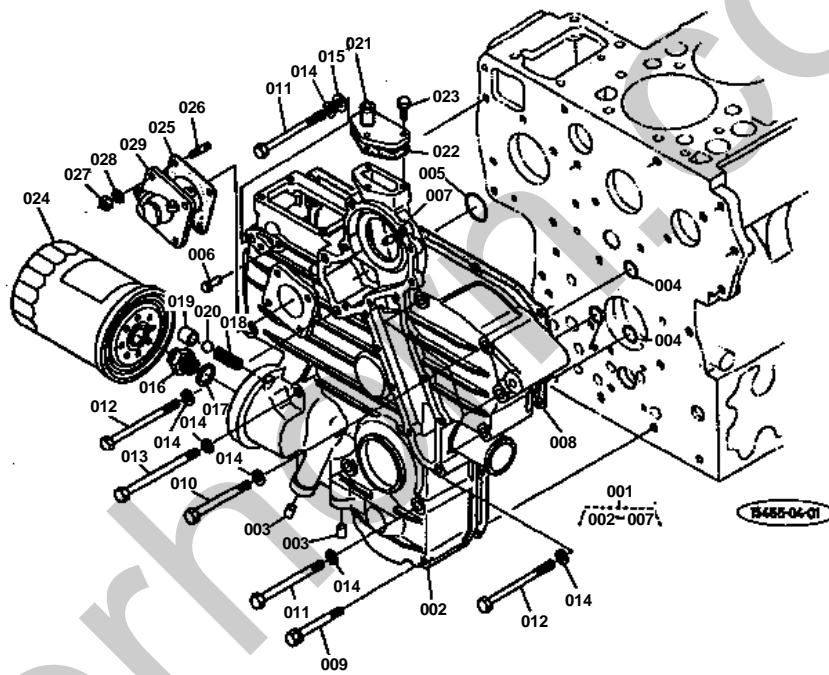



GEAR CASE

↔ Interchangeable; ≠ not interchangeable; ← new for old; → old for new

REF.No	Part No.	Description	Q'ty	S.No.	I/C	REMARKS	Weight (kgf)	Weight (lb)
001	15521-04020	ASSY CASE,GEAR	1				0	0
002	99999-99999	BLANK	0			ORDER BY REF.No.001	0	0
003	15521-33630	PLUG,PIN	2				0.003	0.0066
004	04811-00150	O RING	3				0.001	0.0022
005	04811-00360	O RING	1				0.002	0.0044
006	15221-56280	PIN,START SPRING	1				0.006	0.0132
007	05012-00612	PIN,STRAIGHT	2				0.003	0.0066
008	15521-04130	GASKET,GEAR CASE	1				0	0
009	01123-50860	BOLT	2				0.026	0.0572
010	01153-50870	BOLT	5				0.026	0.0572
011	01153-50880	BOLT	3				0.03	0.066
012	15521-91020	BOLT	3				0.035	0.077
013	01153-50895	BOLT	2				0.035	0.077
014	04512-50080	WASHER,SPRING	13				0.001	0.0022
015	04012-50080	WASHER,PLAIN	1				0.001	0.0022
016	15521-32290	JOINT,PIPE	1				0.05	0.11
017	04011-50180	WASHER,PLAIN	1				0.012	0.0264
018	15241-36950	SPRING	1				0.004	0.0088
019	15521-36930	SEAT,VALVE	1				0.015	0.033
020	07715-03213	BALL	1				0.004	0.0088
021	15521-73320	FLANGE,WATER RETURN	1				0.04	0.088
022	15521-73330	GASKET,WATER RETURN	1				0	0
023	01023-50620	BOLT	3				0.006	0.0132
024	15521-32430	CARTRIDGE,OIL FILTER	1				0	0
025	15221-88130	GASKET,HOUR METER	1				0	0
026	15221-88210	STUD	4				0.005	0.011
027	02056-50060	NUT	4				0.002	0.0044
028	04512-50060	WASHER,SPRING	4				0	0
029	38240-34660	ASSY GEAR CASE,HOUR	1				0.335	0.737

MAIN BEARING CASE

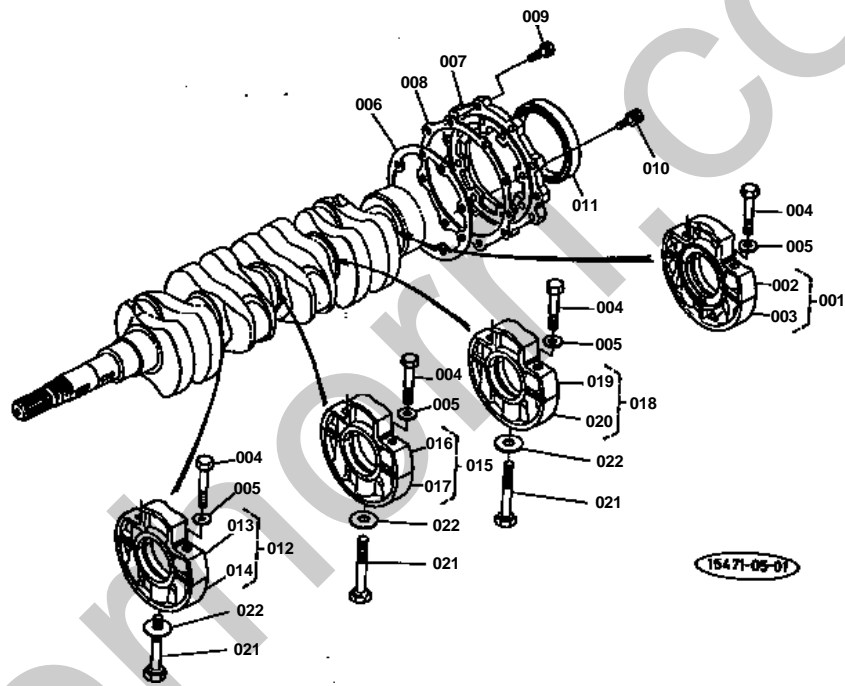



MAIN BEARING CASE

↔ Interchangeable; ≠ not interchangeable; ← new for old; → old for new

REF.No	Part No.	Description	Q'ty	S.No.	I/C	REMARKS	Weight (kgf)	Weight (lb)
001	19202-04040	ASSY CASE,MAIN BEARI	1				1.28	2.816
002	99999-99999	BLANK	0			ORDER BY REF.No.001	0	0
003	99999-99999	BLANK	0			ORDER BY REF.No.001	0	0
004	15521-04540	BOLT,BEARING CASE 1	8				0	0
005	15521-94010	WASHER,PLAIN	8				0.001	0.0022
006	15221-04360	GASKET,BEARING	1				0	0
007	19202-04810	COVER,BEARING	1				0.36	0.792
008	15221-04820	GASKET,COVER	1				0	0
009	01123-50825	BOLT	8				0.013	0.0286
010	01123-50828	BOLT	8				0.014	0.0308
011	19202-04460	SEAL,OIL	1				0.055	0.121
012	15521-04050	ASSY CASE,MAIN BEARI	1				0	0
013	99999-99999	BLANK	0			ORDER BY REF.No.012	0	0
014	99999-99999	BLANK	0			ORDER BY REF.No.012	0	0
015	15521-04060	ASSY CASE,MAIN BEARI	1				0	0
016	99999-99999	BLANK	0			ORDER BY REF.No.015	0	0
017	99999-99999	BLANK	0			ORDER BY REF.No.015	0	0
018	15411-04070	ASSY CASE,MAIN BEARI	1				1.25	2.75
019	99999-99999	BLANK	0			ORDER BY REF.No.018	0	0
020	99999-99999	BLANK	0			ORDER BY REF.No.018	0	0
021	15291-04560	BOLT 2	3				0.06	0.132
022	15521-94020	WASHER,PLAIN	3				0.004	0.0088

AIR CLEANER

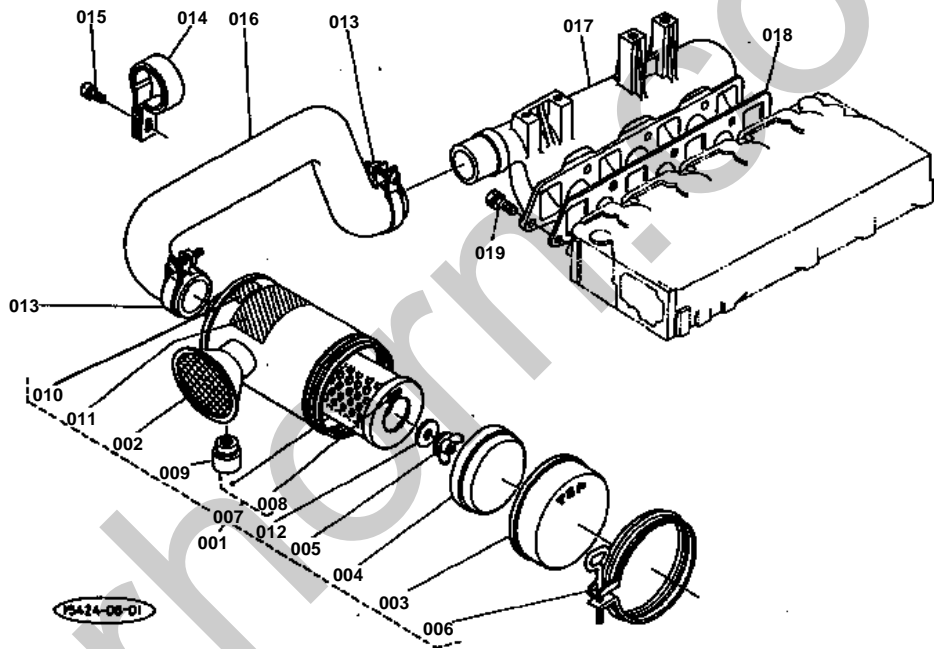



AIR CLEANER

↔ Interchangeable; ≠ not interchangeable; ← new for old; → old for new

REF.No	Part No.	Description	Q'ty	S.No.	I/C	REMARKS	Weight (kgf)	Weight (lb)
001	15401-11010	ASSY CLEANER,AIR	1				2.9	6.38
002	15401-11150	BODY,AIR CLEANER	1				1.15	2.53
003	15401-11160	COVER,AIR CLEANER	1				0.38	0.836
004	15401-11410	COVER,BAFFLE	1				0.05	0.11
005	15401-92620	NUT,WING	1				0.01	0.022
006	15401-11070	ASSY BAND,AIR CLEANER	1				0.115	0.253
007	15401-11080	ASSY ELEMENT,AIR CLEANER	1				0.74	1.628
008	15222-87480	LABEL	1				0.001	0.0022
009	15401-11090	ASSY INDICATER	1				0.021	0.0462
010	15401-87750	MARK,FORM	1				0.001	0.0022
011	15401-87450	LABEL,AIR CLEANER	1				0.002	0.0044
012	15401-94430	WASHER,SEAL	1				0.009	0.0198
013	15401-11720	BAND,PIPE	2				0.05	0.11
014	15401-11700	ASSY HOLDER,INLET PIPE	1				0.08	0.176
015	03004-50812	BOLT	1				0.008	0.0176
016	15401-11620	PIPE,INLET	1				0.84	1.848
017	15461-11760	MANIFOLD,INLET	1				1.155	2.541
018	15471-11823	GASKET,IN-MANIFOLD	1				0	0
019	01123-50822	BOLT	7				0.012	0.0264

EXHAUST MANIFOLD

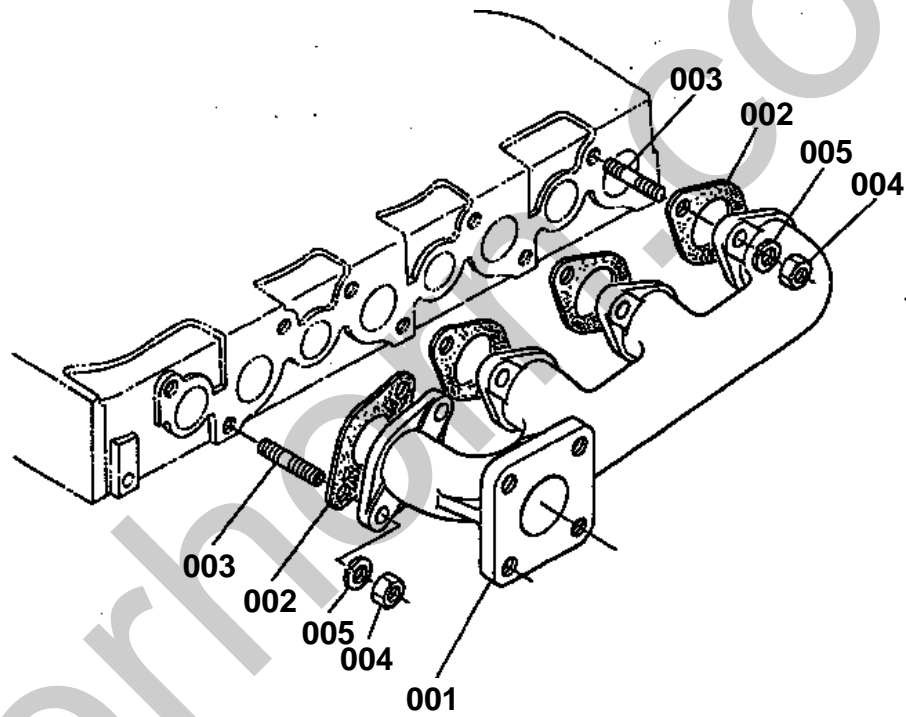



EXHAUST MANIFOLD

↔ Interchangeable; ≠ not interchangeable; ← new for old; → old for new

REF.No	Part No.	Description	Q'ty	S.No.	I/C	REMARKS	Weight (kgf)	Weight (lb)
001	15416-12310	MANIFOLD,EXHAUST	1				0	0
002	15521-12350	GASKET,EX-MANIFOLD	4				0	0
003	15221-91530	STUD	8				0.011	0.0242
004	02156-50080	NUT	8				0.004	0.0088
005	04512-50080	WASHER,SPRING	8				0.001	0.0022

VALVE,ROCKER ARM

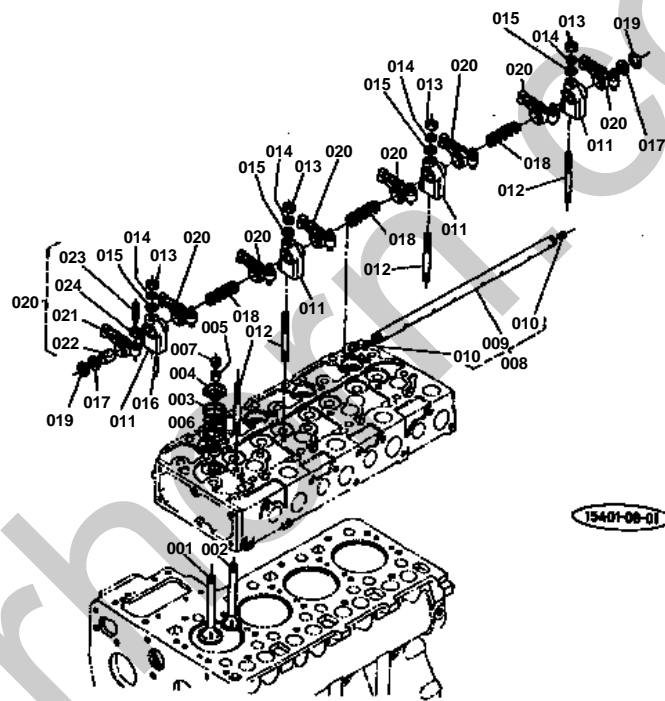

15401-00-01



VALVE,ROCKER ARM

↔ Interchangeable; ≠ not interchangeable; ← new for old; → old for new

REF.No	Part No.	Description	Q'ty	S.No.	I/C	REMARKS	Weight (kgf)	Weight (lb)
001	15221-13110	VALVE,INLET	4				0.062	0.1364
002	15221-13120	VALVE,EXHAUST	4				0.054	0.1188
003	15221-13240	SPRING,VALVE	8				0.036	0.0792
004	15221-13330	RETAINER,VALVE SPRIN	8				0.03	0.066
005	15221-13360	COLLET,VALVE SPRING	16				0	0
006	15221-13150	SEAL,VALVE STEM	8				0.001	0.0022
007	15221-13280	CAP,VALVE	8				0.006	0.0132
008	15401-14050	ASSY SHAFT,ROCKER AR	1				0.335	0.737
009	99999-99999	BLANK	0			ORDER BY REF.No.008	0	0
010	03410-50808	SCREW,SET	2				0	0
011	15221-14350	BRACKET,ROCKER ARM	4				0.044	0.0968
012	15521-91500	STUD	4				0.035	0.077
013	02156-50080	NUT	4				0.004	0.0088
014	04512-50080	WASHER,SPRING	4				0.001	0.0022
015	04012-50080	WASHER,PLAIN	4				0.001	0.0022
016	15221-14420	SCREW,SET	1				0.003	0.0066
017	15221-14430	WASHER,ROCKER ARM SH	2				0.002	0.0044
018	15221-14310	SPRING,ROCKER ARM	3				0.005	0.011
019	04612-00140	CIR-CLIP,EXTERNAL	2				0.001	0.0022
020	15601-14030	ASSY ROCKER ARM	8				0	0
021	99999-99999	BLANK	0			ORDER BY REF.No.020	0	0
022	15221-14180	BUSH,ROCKER ARM	8				0.007	0.0154
023	15521-14230	SCREW,ADJUSTING	8				0.009	0.0198
024	15021-14240	NUT	8				0.003	0.0066

HEAD COVER

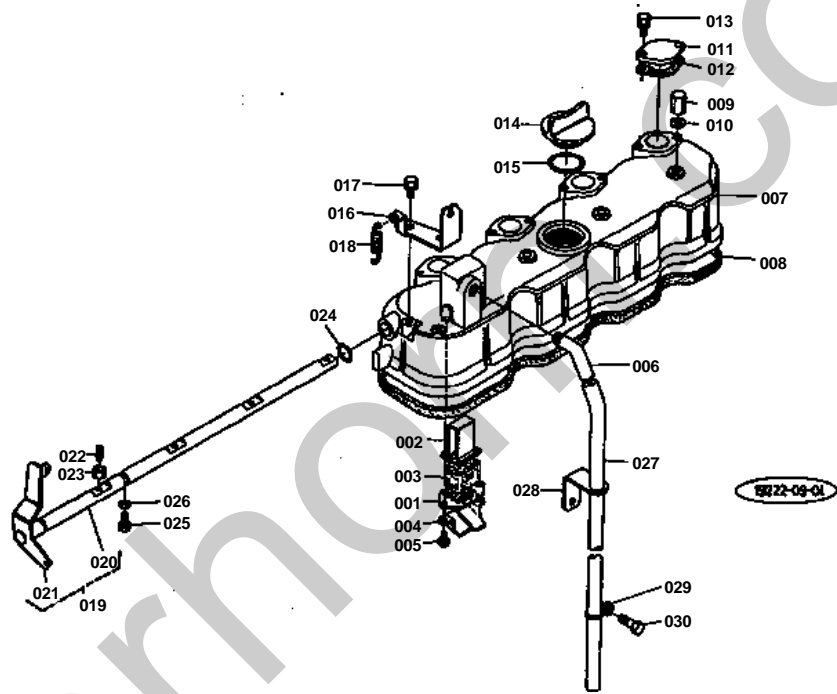



HEAD COVER

↔ Interchangeable; ≠ not interchangeable; ← new for old; → old for new

REF.No	Part No.	Description	Q'ty	S.No.	I/C	REMARKS	Weight (kgf)	Weight (lb)
001	15521-05140	PLATE,ELEMENT 1	1				0.005	0.011
002	15521-05150	PLATE,ELEMENT 2	1				0.01	0.022
003	15521-05670	ELEMENT,BREATHER	1				0.01	0.022
004	15521-05370	OIL SHIELD,BREATHER	1				0.005	0.011
005	15521-93310	SCREW,WITH WASHER	2				0.004	0.0088
006	15521-05550	JOINT,BREATHER PIPE	1				0.04	0.088
007	15471-14510	COVER,CYLINDER HEAD	1				1.48	3.256
008	15471-14520	GASKET,HEAD COVER	1				0.05	0.11
009	15451-92330	NUT,CAP	4				0.015	0.033
010	15021-33660	GASKET	4				0.001	0.0022
011	15221-66630	COVER,DECOMP.HOLE	4				0.035	0.077
012	15221-66640	GASKET,COVER	4				0	0
013	01023-50614	BOLT	8				0.005	0.011
014	15221-33140	PLUG,OIL FILLER	1				0.038	0.0836
015	04811-50300	O RING	1				0.001	0.0022
016	15221-66190	HOLDER,DECOMP.WIRE	1				0.055	0.121
017	01023-50614	BOLT	2				0.005	0.011
018	15221-66280	SPRING,DECOMPRESS	1				0.008	0.0176
019	15471-66040	ASSY SHAFT,DECOMPRES	1				0.485	1.067
020	99999-99999	BLANK	0			ORDER BY REF.No.020	0	0
021	99999-99999	BLANK	0			ORDER BY REF.No.020	0	0
022	15221-66350	BOLT,DECOMPRESS	4				0.005	0.011
023	15221-66360	NUT,DECOMPRESS	4				0.003	0.0066
024	04811-06100	O RING	1				0.001	0.0022
025	15221-66410	BOLT	1				0.005	0.011
026	04512-50060	WASHER,SPRING	1				0	0
027	15521-05510	PIPE,BREATHER	1				0.075	0.165
028	15401-05580	CLAMP,PIPE	1				0.02	0.044
029	15341-05590	CLAMP,PIPE	1				0.003	0.0066
030	01173-51218	BOLT	1				0.028	0.0616

CAMSHAFT

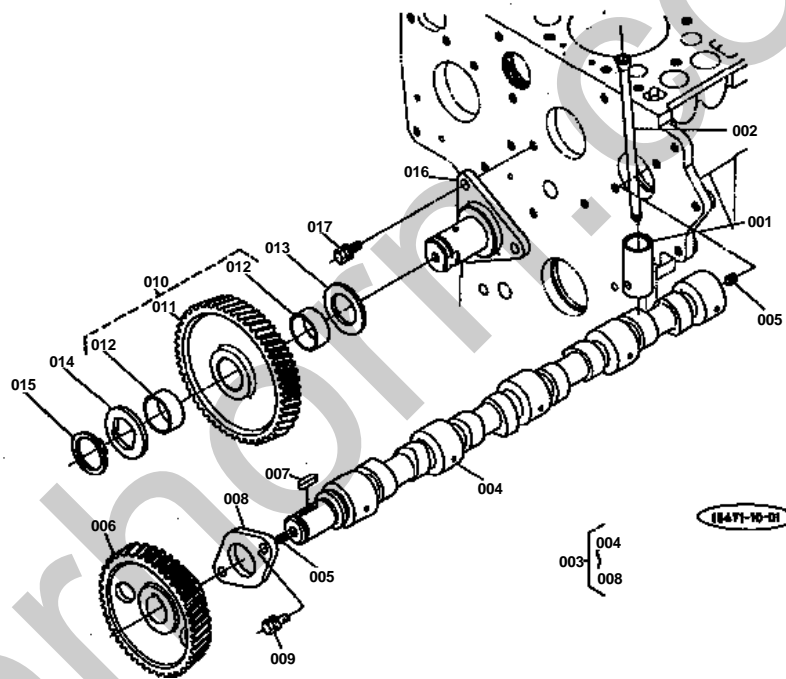



CAMSHAFT

↔ Interchangeable; ≠ not interchangeable; ← new for old; → old for new

REF.No	Part No.	Description	Q'ty	S.No.	I/C	REMARKS	Weight (kgf)	Weight (lb)
001	15221-15550	TAPPET	8				0	0
002	15221-15110	ROD,PUSH	8				0.05	0.11
003	15471-16010	ASSY CAMSHAFT	1				3.26	7.172
004	15471-16150	CAMSHAFT	1				2.4	5.28
005	15521-93610	SCREW,SET	2				0.002	0.0044
006	15521-16510	GEAR,CAMSHAFT	1				0.85	1.87
007	05712-00720	KEY,FEATHER	1				0.008	0.0176
008	15221-16270	STOPPER,CAMSHAFT	1				0.073	0.1606
009	01123-50818	BOLT	2				0.012	0.0264
010	15221-24010	ASSY GEAR,IDLE	1				0.5	1.1
011	99999-99999	BLANK	0			ORDER BY REF.No.010	0	0
012	15221-24980	BUSH,IDLE GEAR	2				0.02	0.044
013	15521-24360	COLLAR 1	1				0.015	0.033
014	15521-24370	COLLAR 2	1				0.015	0.033
015	15221-24320	CIR-CLIP,EXTERNAL	1				0.01	0.022
016	15221-24250	SHAFT,IDLE GEAR	1				0.48	1.056
017	01123-50818	BOLT	3				0.012	0.0264

PISTON,CRANKSHAFT

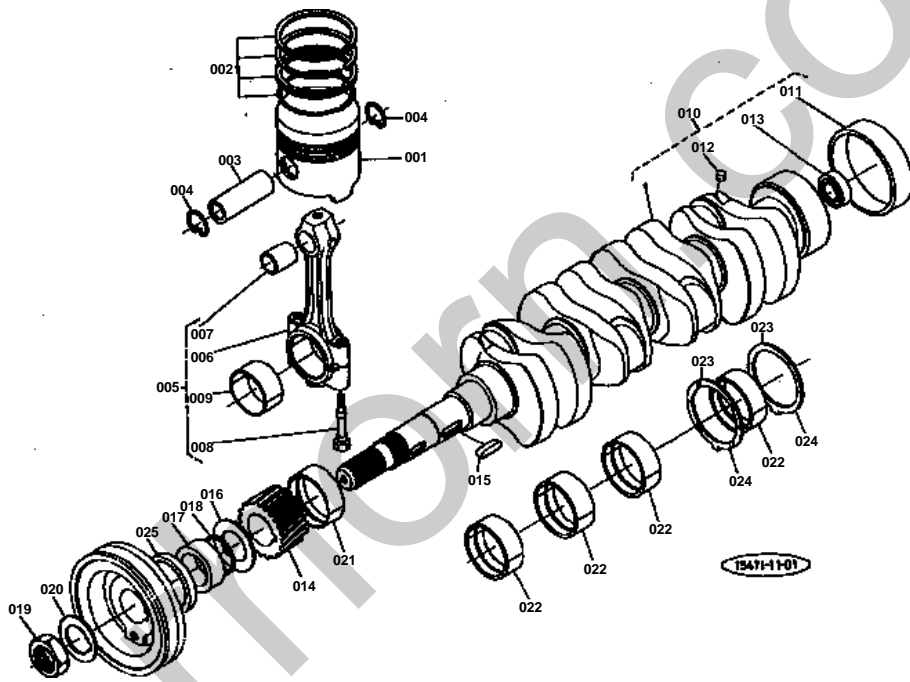



PISTON,CRANKSHAFT

↔ Interchangeable; ≠ not interchangeable; ← new for old; → old for new

REF.No	Part No.	Description	Q'ty	S.No.	I/C	REMARKS	Weight (kgf)	Weight (lb)
001	19223-21110	PISTON	4				0.53	1.166
002	15201-21050	ASSY PISTON RING	4			STD	0	0
002	15201-21090	ASSY PISTON RING	1			+0.5	0	0
003	15521-21310	PISTON PIN	4				0.156	0.3432
004	15221-21330	CIR-CLIP,PISTON PIN	8				0.002	0.0044
005	15521-22010	ASSY CONNECTING ROD	4				0	0
006	99999-99999	BLANK	0			ORDER BY REF.No.005	0	0
007	15221-21980	BUSH,PISTON PIN	4				0	0
008	15521-22140	BOLT,CONNECTING ROD	8				0	0
009	15221-22310	METAL,CRANK PIN	8			STD	0	0
009	15471-22970	METAL,CRANK PIN	1			-0.2	0.04	0.088
009	15471-22980	METAL,CRANK PIN	1			-0.4	0.04	0.088
010	15422-23010	ASSY CRANKSHAFT	1				17	37.4
011	19202-23280	SLEEVE,CRANKSHAFT	1				0.09	0.198
012	15221-33630	PLUG PIN	4				0.001	0.0022
013	08121-06002	BEARING,BALL	1				0.03	0.066
014	15471-24110	GEAR,CRANKSHAFT	1				0.375	0.825
015	05712-00720	KEY,FEATHER	1				0.008	0.0176
016	15471-23310	OIL SLINGER	1				0	0
017	19202-23250	COLLAR,CRANKSHAFT	1				0.065	0.143
018	04811-10300	O RING	1				0.001	0.0022
019	15221-23360	NUT,CRANKSHAFT	1				0.11	0.242
020	15221-23380	WASHER,CRANKSHAFT	1				0.02	0.044
021	15221-23470	METAL,CRANKSHAFT 1	1			STD	0	0
021	15221-23910	METAL,CRANKSHAFT 1	1			-0.2	0.058	0.1276
021	15221-23920	METAL,CRANKSHAFT 1	1			-0.4	0	0
022	15221-23480	METAL,CRANKSHAFT 2	8			STD	0	0
022	15221-23930	METAL,CRANKSHAFT 2	1			-0.2	0.055	0.121
022	15221-23940	METAL,CRANKSHAFT 2	1			-0.4	0.056	0.1232
023	15521-23530	METAL,SIDE 1	2			STD	0.01	0.022
023	15221-23950	METAL,SIDE 1	1			+0.2	0	0
023	15221-23960	METAL,SIDE 1	1			+0.4	0.009	0.0198
024	19202-23540	METAL,SIDE 2	2			STD	0.01	0.022
024	15221-23970	METAL,SIDE 2	1			+0.2	0.009	0.0198
024	15221-23980	METAL,SIDE 2	1			+0.4	0.009	0.0198
025	09550-00001	SEAL,OIL	1				0.015	0.033

FLYWHEEL

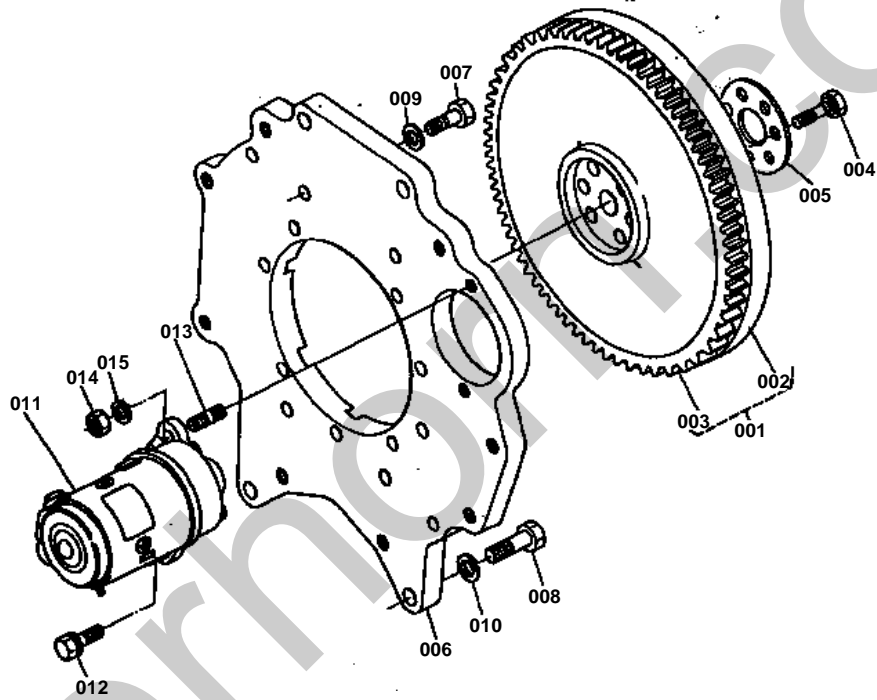



FLYWHEEL

↔ Interchangeable; ≠ not interchangeable; ← new for old; → old for new

REF.No	Part No.	Description	Q'ty	S.No.	I/C	REMARKS	Weight (kgf)	Weight (lb)
001	15424-25010	ASSY FLYWHEEL	1				0	0
002	99999-99999	BLANK	0			ORDER BY REF.No.001	0	0
003	15606-63820	GEAR,RING	1				1.44	3.168
004	15424-25160	BOLT,FLYWHEEL	6				0.06	0.132
005	15521-25170	WASHER,FLYWHEEL	1				0.06	0.132
006	15415-04620	PLATE,REAR END	1				13	28.6
007	01073-51030	BOLT	11				0.028	0.0616
008	01073-51240	BOLT	2				0.049	0.1078
009	04512-50100	WASHER,SPRING	11				0	0
010	04512-50120	WASHER,SPRING	2				0	0
011	15601-63010	ASSY STARTER	1				0	0
012	01133-51030	BOLT	1				0.025	0.055
013	01517-51028	STUD	1				0.022	0.0484
014	02176-50100	NUT	1				0.005	0.011
015	04512-50100	WASHER,SPRING	1				0	0

STARTER SECTION PARTS

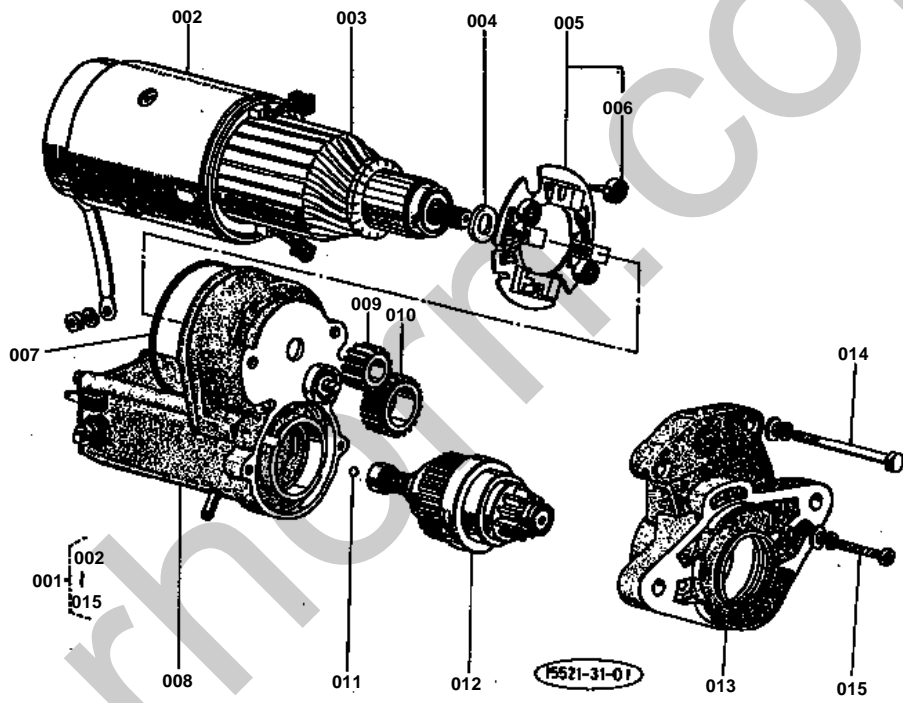



STARTER SECTION PARTS

↔ Interchangeable; ≠ not interchangeable; ← new for old; → old for new

REF.No	Part No.	Description	Q'ty	S.No.	I/C	REMARKS	Weight (kgf)	Weight (lb)
001	15601-63010	ASSY STARTER	1				0	0
002	15401-63080	YOKE	1				1.2	2.64
003	19212-63070	ARMATURE	1				1	2.2
004	19212-96670	GASKET	1				0.001	0.0022
005	15401-63380	HOLDER,BRUSH	1				0.1	0.22
006	15401-63390	SPRING,BRUSH	4				0.003	0.0066
007	15401-96660	GASKET	1				0.002	0.0044
008	15521-63020	SWITCH,MAGNET	1				1.29	2.838
009	15521-63260	GEAR 1	1				0.03	0.066
010	15401-63270	GEAR 2	1				0.043	0.0946
011	15451-97130	BALL	1				0	0
012	15601-63042	CLUTCH	1				0.75	1.65
013	15401-63030	FRAME,DRIVE END	1				0.35	0.77
014	15401-63320	BOLT,THROUGH	2				0.017	0.0374
015	15401-93310	SCREW	2				0.01	0.022

FUEL CAMSHAFT

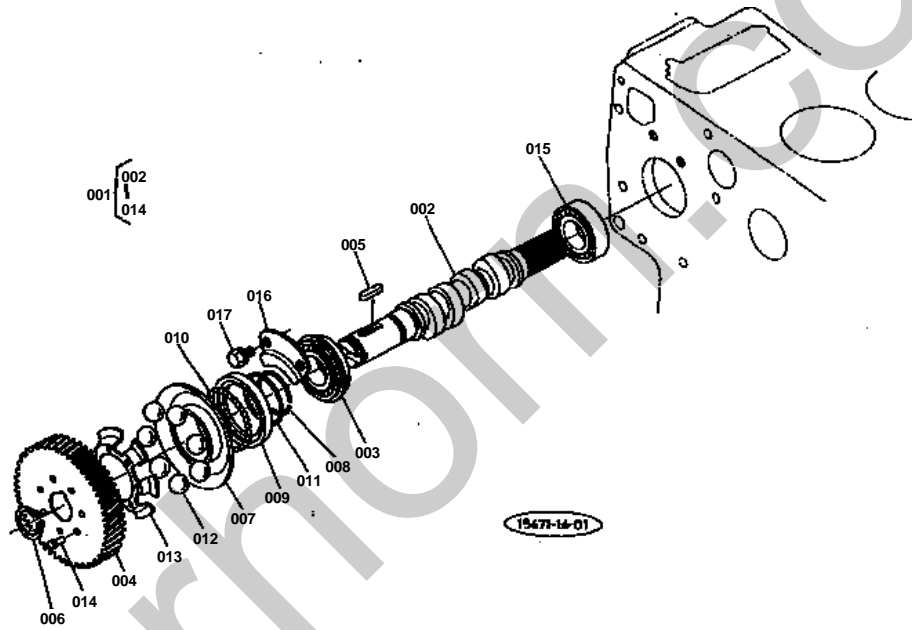



FUEL CAMSHAFT

↔ Interchangeable; ≠ not interchangeable; ← new for old; → old for new

REF.No	Part No.	Description	Q'ty	S.No.	I/C	REMARKS	Weight (kgf)	Weight (lb)
001	15471-16020	ASSY CAMSHAFT,FUEL	1				2.3	5.06
002	15471-16170	CAMSHAFT,FUEL	1				0.96	2.112
003	08153-06205	BEARING,BALL	1				0.13	0.286
004	15401-51150	GEAR,INJECTION PUMP	1				0.8	1.76
005	05712-00525	KEY,FEATHER	1				0.005	0.011
006	04612-00240	CIR-CLIP,EXTERNAL	1				0.002	0.0044
007	15221-55450	SLEEVE,GOVERNOR	1				0.19	0.418
008	15221-55470	CIR-CLIP,SLEEVE	1				0.003	0.0066
009	15221-55690	CASE,GOVERNOR BALL	1				0	0
010	07715-03205	BALL	39				0.001	0.0022
011	15221-55740	CIR-CLIP,BALL CASE	1				0.002	0.0044
012	07715-00805	BALL	7				0.016	0.0352
013	15521-55650	GUIDE,GOVERNOR BALL	1				0.035	0.077
014	05611-10310	RIVET	7				0.001	0.0022
015	08240-00001	BEARING,BALL	1				0.19	0.418
016	15221-16320	STOPPER,FUEL CAMSHAF	1				0.02	0.044
017	01123-50814	BOLT	2				0	0

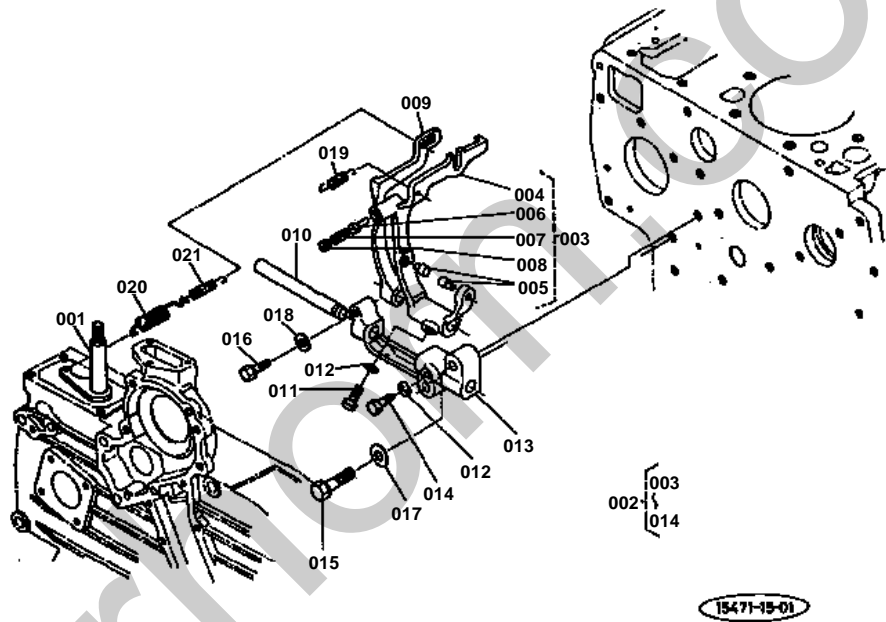



GOVERNOR

↔ Interchangeable; ≠ not interchangeable; ← new for old; → old for new

REF.No	Part No.	Description	Q'ty	S.No.	I/C	REMARKS	Weight (kgf)	Weight (lb)
001	15601-56020	ASSY LEVER,GOVERNOR	1				0.055	0.121
002	15471-56050	ASSY LEVER,FORK	1				0.41	0.902
003	15471-56040	ASSY LEVER,FORK 1	1				0.195	0.429
004	99999-99999	BLANK	0			ORDER BY REF.No.003	0	0
005	99999-99999	BLANK	0			ORDER BY REF.No.003	0	0
006	99999-99999	BLANK	0			ORDER BY REF.No.003	0	0
007	99999-99999	BLANK	0			ORDER BY REF.No.003	0	0
008	99999-99999	BLANK	0			ORDER BY REF.No.003	0	0
009	99999-99999	BLANK	0			ORDER BY REF.No.002	0	0
010	15221-56150	SHAFT,FORK LEVER	1				0.1	0.22
011	15021-56240	BOLT,LEVER SHAFT	1				0.005	0.011
012	04512-50060	WASHER,SPRING	2				0	0
013	15221-56230	HOLDER,FORK LEVER	1				0.1	0.22
014	15221-66410	BOLT	1				0.005	0.011
015	01123-50832	BOLT	2				0.016	0.0352
016	01023-50628	BOLT	1				0.015	0.033
017	04012-50080	WASHER,PLAIN	2				0.001	0.0022
018	04012-50060	WASHER,PLAIN	1				0.001	0.0022
019	15601-56480	SPRING,START	1				0.002	0.0044
020	15521-56410	SPRING,GOVERNOR 1	1				0	0
021	15521-56420	SPRING,GOVERNOR 2	1				0.002	0.0044

SPEED CONTROL PLATE

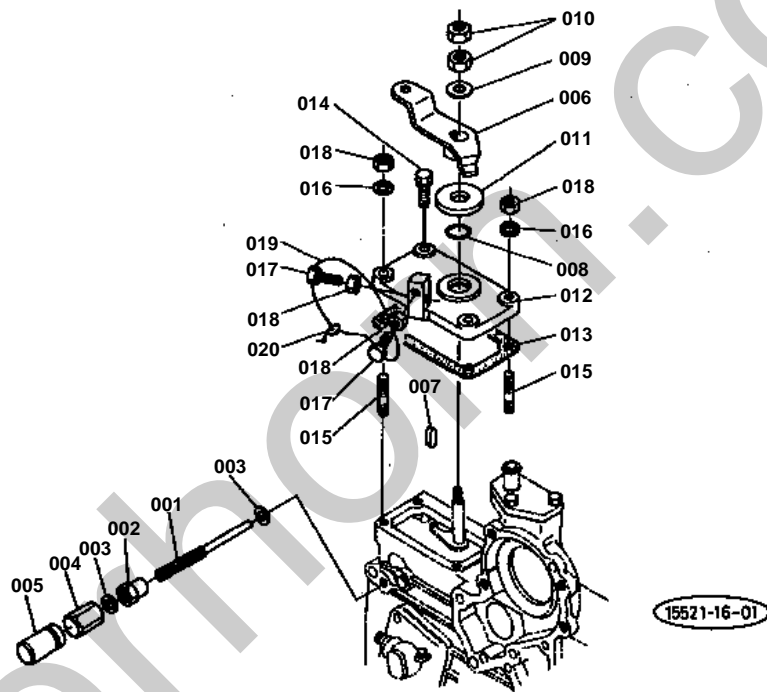



SPEED CONTROL PLATE

↔ Interchangeable; ≠ not interchangeable; ← new for old; → old for new

REF.No	Part No.	Description	Q'ty	S.No.	I/C	REMARKS	Weight (kgf)	Weight (lb)
001	15601-54120	BOLT,ADJUSTING	1				0.011	0.0242
002	15601-92010	NUT	1				0	0
003	15601-96650	GASKET	2				0.001	0.0022
004	15601-54220	NUT,CAP	1				0	0
005	15601-54420	CAP	1				0	0
006	15471-57150	LEVER,SPEED CONTROL	1				0.05	0.11
007	05712-00408	KEY,FEATHER	1				0.001	0.0022
008	04811-00120	O RING	1				0.001	0.0022
009	04013-50080	WASHER,PLAIN	1				0	0
010	02112-50080	NUT	2				0.003	0.0066
011	17011-57380	PLATE,FRICITION	1				0	0
012	15521-57110	PLATE,SPEED CONTROL	1				0	0
013	15221-57210	GASKET,CONTROL PLATE	1				0	0
014	01023-50620	BOLT	2				0.006	0.0132
015	15221-88210	STUD	2				0.005	0.011
016	04512-50060	WASHER,SPRING	2				0	0
017	15108-57280	STOPPER	2				0.008	0.0176
018	02056-50060	NUT	4				0.002	0.0044
019	99999-99999	BLANK	0			NON SALE	0	0
020	99999-99999	BLANK	0			NON SALE	0	0

ENGINE STOP LEVER

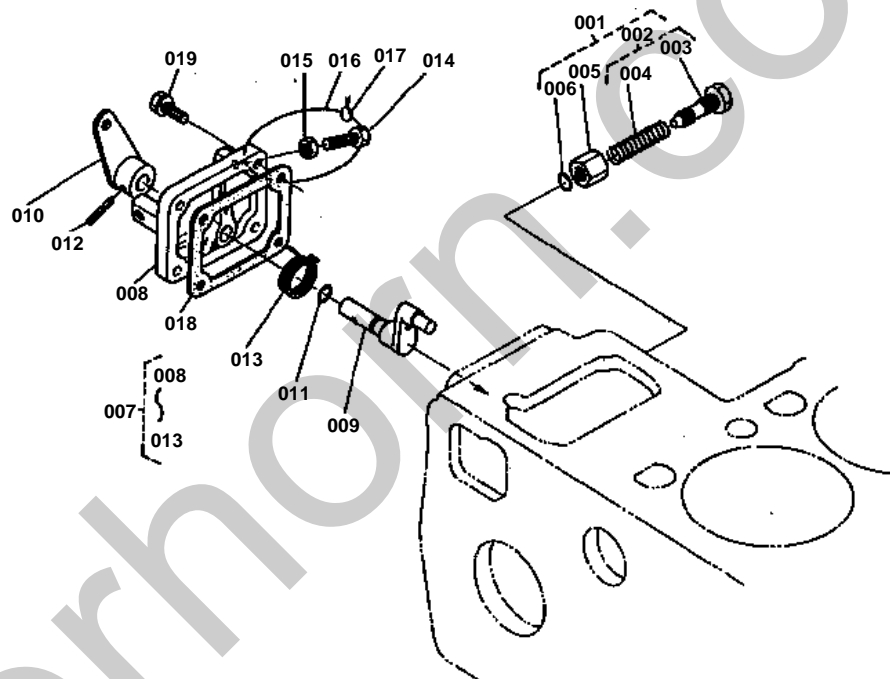



ENGINE STOP LEVER

↔ Interchangeable; ≠ not interchangeable; ← new for old; → old for new

REF.No	Part No.	Description	Q'ty	S.No.	I/C	REMARKS	Weight (kgf)	Weight (lb)
001	15471-54090	ASSY APPARATUS,IDLE	1				0.025	0.055
002	15471-54100	ASSY BOLT,ADJUSTING	1				0.015	0.033
003	15471-54250	BOLT,ADJUSTING	1				0.02	0.044
004	15521-54260	SPRING	1				0.001	0.0022
005	15471-92010	NUT	1				0.07	0.154
006	04811-00060	O RING	1				0.001	0.0022
007	15521-57700	ASSY LEVER,ENGINE ST	1				0	0
008	15521-51650	COVER,INJECTION PUMP	1				0	0
009	15611-57740	SHAFT,LEVER	1				0.04	0.088
010	99999-99999	BLANK	0			ORDER BY REF.No.007	0	0
011	04811-10070	O RING	1				0.001	0.0022
012	05411-00420	PIN,SPRING	1				0.001	0.0022
013	15611-57510	SPRING	1				0.003	0.0066
014	15108-57280	STOPPER	1				0.008	0.0176
015	02056-50060	NUT	1				0.002	0.0044
016	99999-99999	BLANK	0			NON SALE	0	0
017	99999-99999	BLANK	0			NON SALE	0	0
018	15221-51660	GASKET,PUMP COVER	1				0	0
019	01023-50618	BOLT	4				0.006	0.0132

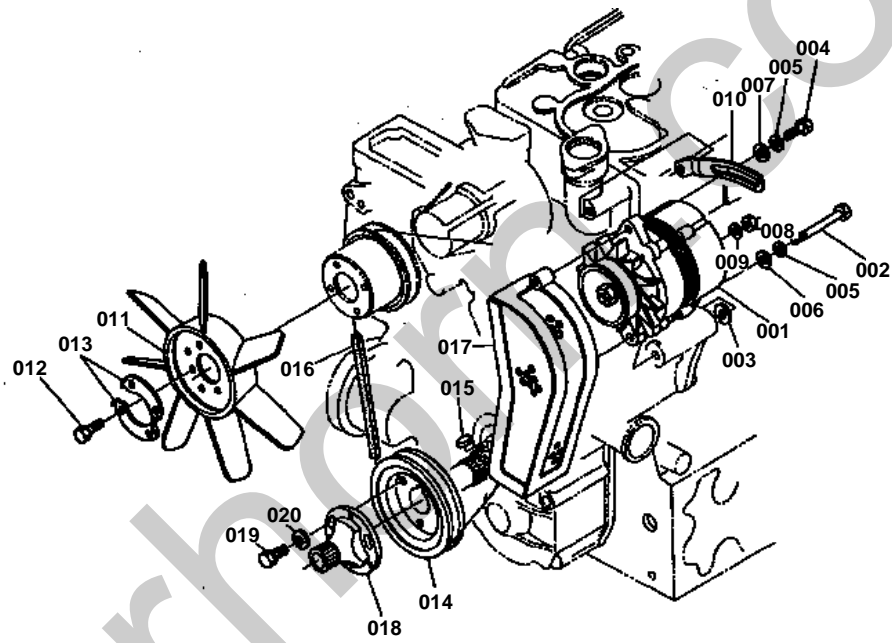

19424-18-01

**DYNAMO**

↔ Interchangeable; ≠ not interchangeable; ← new for old; → old for new

REF.No	Part No.	Description	Q'ty	S.No.	I/C	REMARKS	Weight (kgf)	Weight (lb)
001	15471-64010	ASSY DYNAMO	1				3.68	8.096
002	15521-91030	BOLT	1				0	0
003	15521-94030	WASHER,PLAIN	1				0.01	0.022
004	01153-50835	BOLT	1				0.016	0.0352
005	04512-50080	WASHER,SPRING	2				0.001	0.0022
006	04012-50080	WASHER,PLAIN	1				0.001	0.0022
007	04015-50080	WASHER,PLAIN	1				0	0
008	02056-50060	NUT	1				0.002	0.0044
009	04512-50060	WASHER,SPRING	1				0	0
010	15321-64420	STAY,DYNAMO	1				0.1	0.22
011	15521-74110	FAN,COOLING	1				0.67	1.474
012	01053-50618	BOLT	4				0.006	0.0132
013	15321-74230	WASHER,FAN 1	2				0.005	0.011
014	15424-74280	PULLEY,FAN DRIVE	1				1.55	3.41
015	05712-00720	KEY,FEATHER	1				0.008	0.0176
016	15469-97010	BELT	1				0.095	0.209
017	34260-13860	COVER,BELT LH	1				0	0
018	35370-88530	FLANGE	1				0.57	1.254
019	01123-50825	BOLT	3				0.013	0.0286
020	04013-50080	WASHER,PLAIN	3				0	0

DYNAMO SECTION PARTS

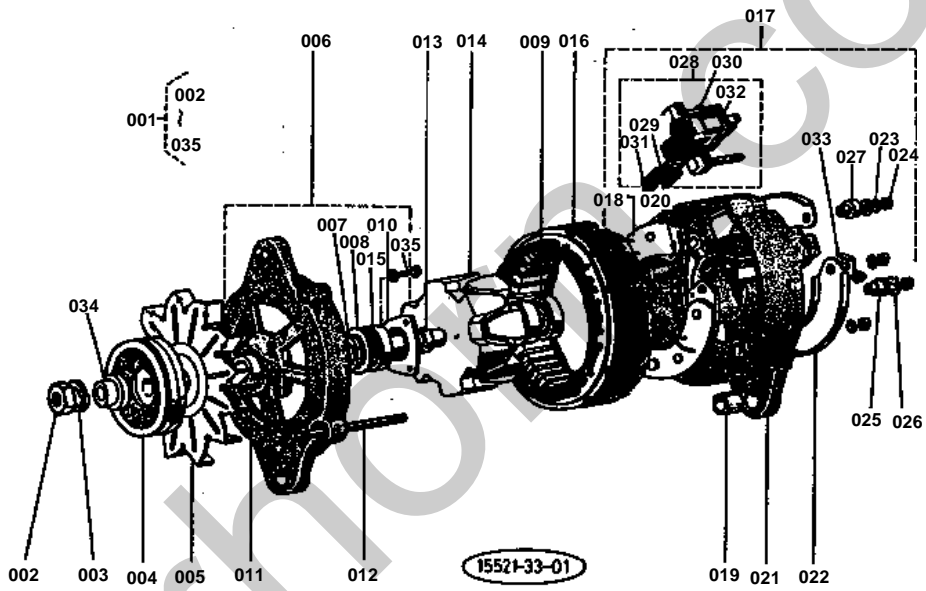



DYNAMO SECTION PARTS

↔ Interchangeable; ≠ not interchangeable; ← new for old; → old for new

REF.No	Part No.	Description	Q'ty	S.No.	I/C	REMARKS	Weight (kgf)	Weight (lb)
001	15471-64010	ASSY DYNAMO	1				3.68	8.096
002	15221-92010	NUT	1				0.012	0.0264
003	15221-94070	WASHER,SPRING	1				0.008	0.0176
004	15471-64110	PULLEY,DYNAMO	1				0.435	0.957
005	15221-64130	FAN,DYNAMO	1				0	0
006	15321-64020	FRAME,DRIVE END	1				0	0
007	15221-64790	FELT,OIL	1				0.001	0.0022
008	15221-64830	COVER,FELT	1				0.003	0.0066
009	08121-06201	BEARING,BALL	1				0.036	0.0792
010	15221-64710	PLATE,RETAINER	1				0.018	0.0396
011	15221-64150	COLLAR	1				0.008	0.0176
012	15321-64260	BOLT,THROUGH	2				0.008	0.0176
013	15321-64170	SPACER	1				0.007	0.0154
014	15606-64030	ARMATURE	1				1.34	2.948
015	08141-06202	BEARING,BALL	1				0.043	0.0946
016	15606-64050	YOKE	1				0.76	1.672
017	15321-64070	ASSY FRAME,END	1				0.52	1.144
018	15321-64850	ASSY RECTIFIER	1				0.134	0.2948
019	15221-64210	BUSH	1				0.007	0.0154
020	15321-64880	WASHER,INSULATION	1				0.001	0.0022
021	15321-64060	FRAME,END	1				0.298	0.6556
022	15321-64230	COVER,END	1				0.029	0.0638
023	04512-50050	WASHER,SPRING	5				0	0
024	15221-92030	NUT	5				0.001	0.0022
025	15321-64920	BUSH,INSULATION	1				0.001	0.0022
026	15321-94080	WASHER	1				0	0
027	15221-64910	BUSH,INSULATION	1				0.001	0.0022
028	15321-64310	ASSY HOLDER,BRUSH	1				0.039	0.0858
029	15221-64330	SPRING,BRUSH	2				0.001	0.0022
030	15221-64880	WASHER,INSULATION	2				0.001	0.0022
031	15221-64090	BRUSH	2				0.002	0.0044
032	15321-64940	INSULATOR,TERMINAL	1				0.001	0.0022
033	15321-67570	CLAMP,CORD	1				0.04	0.088
034	15321-64170	SPACER	1				0.007	0.0154
035	01050-50516	BOLT	2				0	0

RADIATOR

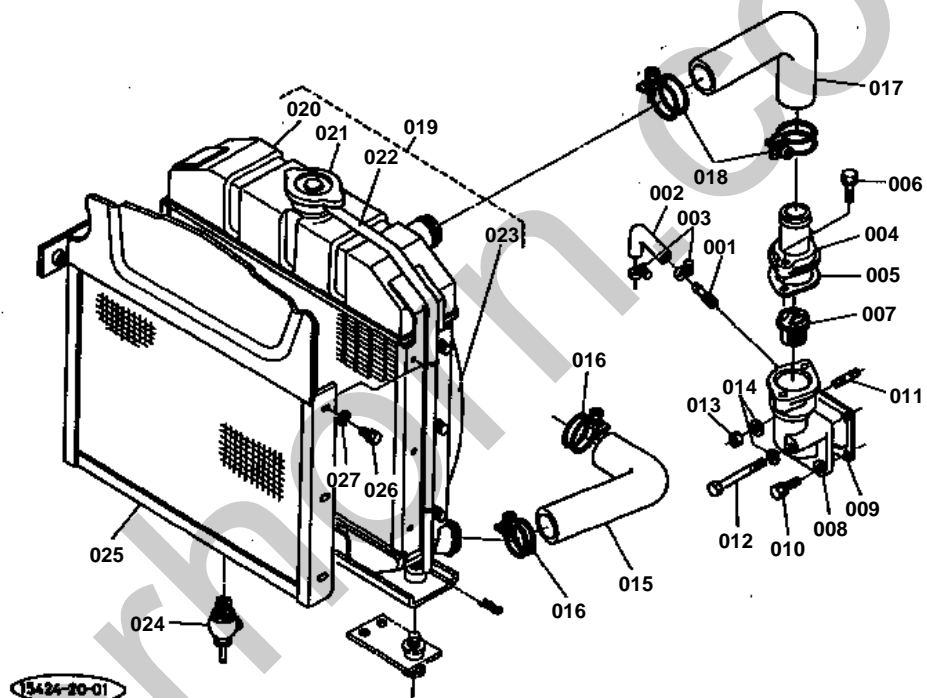



RADIATOR

↔ Interchangeable; ≠ not interchangeable; ← new for old; → old for new

REF.No	Part No.	Description	Q'ty	S.No.	I/C	REMARKS	Weight (kgf)	Weight (lb)
001	15321-73340	PIPE,WATER RETURN	1				0.016	0.0352
002	15521-73340	PIPE,WATER RETURN	1				0.025	0.055
003	15109-73360	BAND,PIPE	2				0.01	0.022
004	15321-73260	COVER,THERMOSTAT	1				0.107	0.2354
005	15321-73270	GASKET,THERMOSTAT CO	1				0	0
006	01123-50835	BOLT	2				0.02	0.044
007	15321-73010	ASSY THERMOSTAT	1				0.068	0.1496
008	15521-72910	FLANGE,WATER	1				0	0
009	15521-72920	GASKET,WATER FLANGE	1				0	0
010	01123-50822	BOLT	2				0.012	0.0264
011	01513-50822	STUD	1				0.01	0.022
012	01153-50870	BOLT	1				0.026	0.0572
013	02156-50080	NUT	1				0.004	0.0088
014	04512-50080	WASHER,SPRING	2				0.001	0.0022
015	15321-72850	PIPE,WATER 1	1				0.181	0.3982
016	15108-72870	BAND	2				0.027	0.0594
017	15401-72940	PIPE,WATER 4	1				0.145	0.319
018	15108-72870	BAND	2				0.027	0.0594
019	15411-72060	ASSY RADIATOR	1				0	0
020	99999-99999	BLANK	0			ORDER BY REF.No.019	0	0
021	15101-72030	CAP,RADIATOR	1				0.075	0.165
022	15401-72710	PIPE,WATER OVER FLOW	1				0.032	0.0704
023	15411-72330	SHROUD,FAN	1				1.12	2.464
024	14301-73110	COCK,DRAIN	1				0.094	0.2068
025	15411-72250	NET,RADIATOR	1				1.44	3.168
026	01023-50612	BOLT	6				0.005	0.011
027	04013-50060	WASHER,PLAIN	6				0	0

WATER PUMP

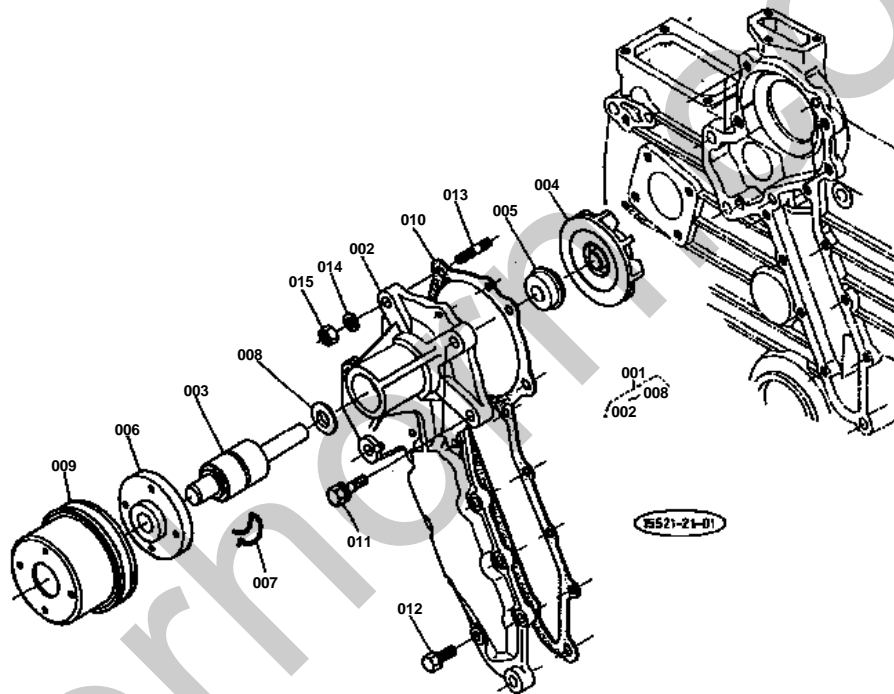



WATER PUMP

↔ Interchangeable; ≠ not interchangeable; ← new for old; → old for new

REF.No	Part No.	Description	Q'ty	S.No.	I/C	REMARKS	Weight (kgf)	Weight (lb)
001	15521-73030	ASSY PUMP,WATER	1				0	0
002	99999-99999	BLANK	0			ORDER BY REF.No.001	0	0
003	15521-73550	BEARING	1				0.235	0.517
004	15321-73510	IMPELLER,WATER PUMP	1				0.22	0.484
005	15121-73050	SET,SEAL	1				0.018	0.0396
006	15521-73520	FLANGE,WATER PUMP SH	1				0.25	0.55
007	15521-94810	PIN,SNAP	1				0.001	0.0022
008	15121-73620	SLINGER	1				0.002	0.0044
009	15471-74250	PULLEY,FAN	1				0.3	0.66
010	15521-73430	GASKET,WATER PUMP	1				0	0
011	01123-50828	BOLT	2				0.014	0.0308
012	01023-50618	BOLT	8				0.006	0.0132
013	01518-50822	STUD	2				0.012	0.0264
014	04512-50080	WASHER,SPRING	2				0.001	0.0022
015	02156-50080	NUT	2				0.004	0.0088

INJECTION PUMP

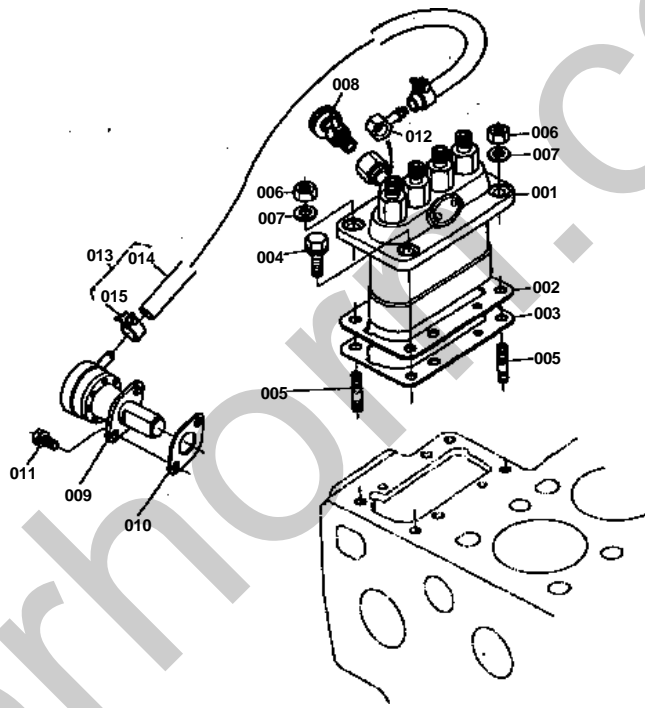



INJECTION PUMP

↔ Interchangeable; ≠ not interchangeable; ← new for old; → old for new

REF.No	Part No.	Description	Q'ty	S.No.	I/C	REMARKS	Weight (kgf)	Weight (lb)
001	15461-51010	ASSY PUMP,INJECTION	1				2.6	5.72
002	15401-52110	SHIM	3				0	0
003	15471-52110	SHIM	1				0.01	0.022
004	01123-50822	BOLT	4				0.012	0.0264
005	01513-50822	STUD	2				0.01	0.022
006	02156-50080	NUT	2				0.004	0.0088
007	04512-50080	WASHER,SPRING	2				0.001	0.0022
008	14311-60504	ASSY COCK,JET START	1				0.034	0.0748
009	15381-52030	ASSY PUMP,FUEL	1				0	0
010	15241-52140	GASKET,FUEL PUMP	1				0	0
011	01023-50616	BOLT	2				0.005	0.011
012	14111-42410	JOINT,EYE	1				0.025	0.055
013	15471-42010	ASSY PIPE,FUEL	1				0.035	0.077
014	99999-99999	BLANK	0			ORDER BY REF.No.015	0	0
015	14301-42750	CLIP,PIPE	2				0.005	0.011

INJECTION PUMP SECTION PARTS

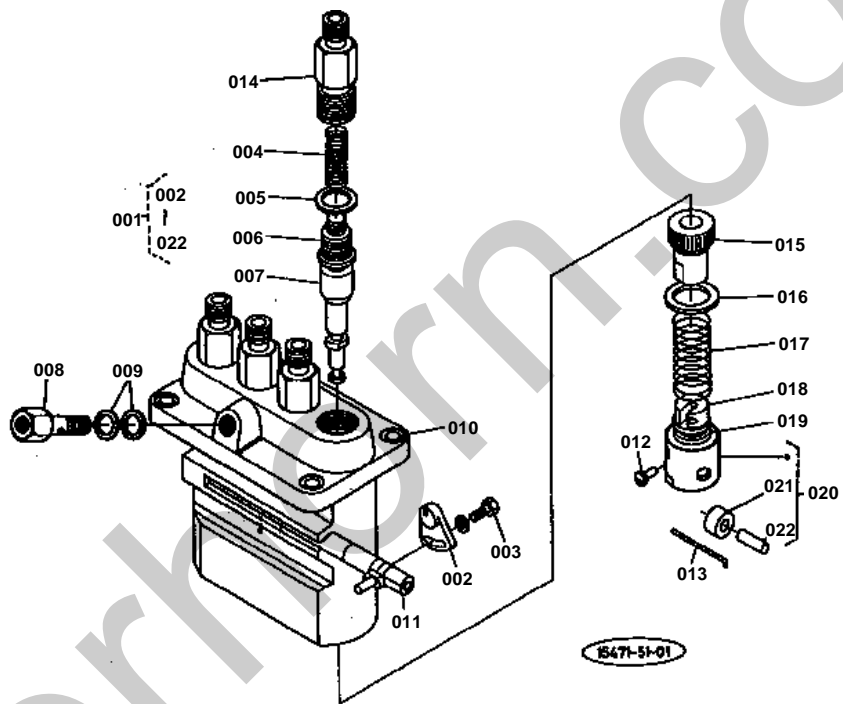



INJECTION PUMP SECTION PARTS

↔ Interchangeable; ≠ not interchangeable; ← new for old; → old for new

REF.No	Part No.	Description	Q'ty	S.No.	I/C	REMARKS	Weight (kgf)	Weight (lb)
001	15461-51010	ASSY PUMP,INJECTION	1				2.6	5.72
002	15221-51390	PLATE,ADJUST	3				0	0
003	15221-91030	BOLT	3				0	0
004	15221-51230	SPRING,DELIVERY VALV	4				0.002	0.0044
005	15221-51240	GASKET,DELIVERY VALV	4				0.001	0.0022
006	15221-51030	VALVE,DELIVERY	4				0.012	0.0264
007	15221-51050	ELEMENT,PUMP	4				0.053	0.1166
008	15471-51320	SCREW	1				0.032	0.0704
009	15221-96650	GASKET	2				0.001	0.0022
010	99999-99999	BLANK	0			ORDER BY REF.No.001	0	0
011	15401-51060	RACK,CONTROL	1				0.05	0.11
012	15221-51250	PIN,TAPPET GUIDE	4				0.001	0.0022
013	15221-51430	PIN,CLAMP	2				0.001	0.0022
014	15601-51220	HOLDER,DELIVERY VALV	4				0.055	0.121
015	15221-51380	SLEEVE,CONTROL	4				0	0
016	15221-51270	SEAT,SPRING UPPER	4				0.004	0.0088
017	15221-51280	SPRING,PLUNGER	4				0.015	0.033
018	15221-51290	SEAT,SPRING UNDER	4				0.01	0.022
019	15221-51490	SHIM	4				0.002	0.0044
020	15221-51070	ASSY TAPPET	4				0.039	0.0858
021	99999-99999	BLANK	0			ORDER BY REF.No.020	0	0
022	99999-99999	BLANK	0			ORDER BY REF.No.020	0	0

NOZZLE HOLDER

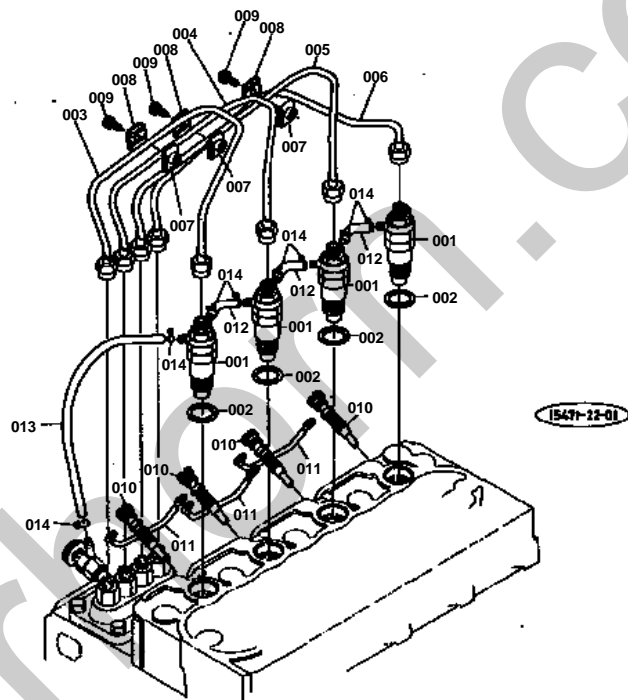



NOZZLE HOLDER

↔ Interchangeable; ≠ not interchangeable; ← new for old; → old for new

REF.No	Part No.	Description	Q'ty	S.No.	I/C	REMARKS	Weight (kgf)	Weight (lb)
001	15271-53020	ASSY HOLDER,NOZZLE 2	4				0.26	0.572
002	17011-53620	GASKET	4				0.003	0.0066
003	15221-53710	PIPE,INJECTION 1	1				0	0
004	15221-53720	PIPE,INJECTION 2	1				0	0
005	15321-53730	PIPE,INJECTION 3	1				0	0
006	15401-53740	PIPE,INJECTION 4	1				0	0
007	15121-53850	CLAMP,PIPE 1	3				0	0
008	15121-53860	CLAMP,PIPE 2	3				0	0
009	03024-50520	SCREW,WITH WASHER	3				0.004	0.0088
010	15521-65510	GLOW PLUG	4				0.025	0.055
011	15401-65560	CORD,GLOW PLUG	3				0.005	0.011
012	15221-42510	PIPE,FUEL OVER FLOW	3				0.005	0.011
013	15471-42520	PIPE,FUEL OVER FLOW	1				0	0
014	14971-42750	CLIP,PIPE	8				0.001	0.0022

NOZZLE HOLDER SECTION PARTS

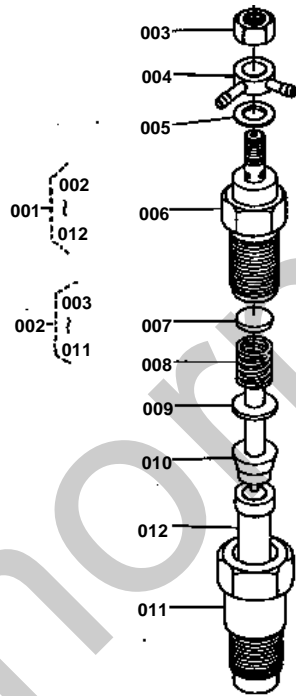

19471-92-01



NOZZLE HOLDER SECTION PARTS

↔ Interchangeable; ≠ not interchangeable; ← new for old; → old for new

REF.No	Part No.	Description	Q'ty	S.No.	I/C	REMARKS	Weight (kgf)	Weight (lb)
001	15271-53020	ASSY HOLDER,NOZZLE 2	4				0.26	0.572
002	99999-99999	BLANK	0			ORDER BY REF.No.001	0	0
003	15221-92020	NUT	4				0.011	0.0242
004	15221-95690	JOINT,EYE 2	4				0.022	0.0484
005	15221-94020	WASHER,PLAIN	4				0.002	0.0044
006	99999-99999	BLANK	0			ORDER BY REF.No.001	0	0
007	15221-53230	WASHER,ADJUSTING	4				0.001	0.0022
008	15221-53170	SPRING,NOZZLE	4				0.01	0.022
009	15221-53350	PIECE,DISTANCE	4				0.016	0.0352
010	15221-53160	ROD,PUSH	4				0.003	0.0066
011	15221-53280	NUT,NOZZLE	4				0.068	0.1496
012	15021-53610	PIECE,NOZZLE	4				0	0

OIL HYDRAULIC PUMP

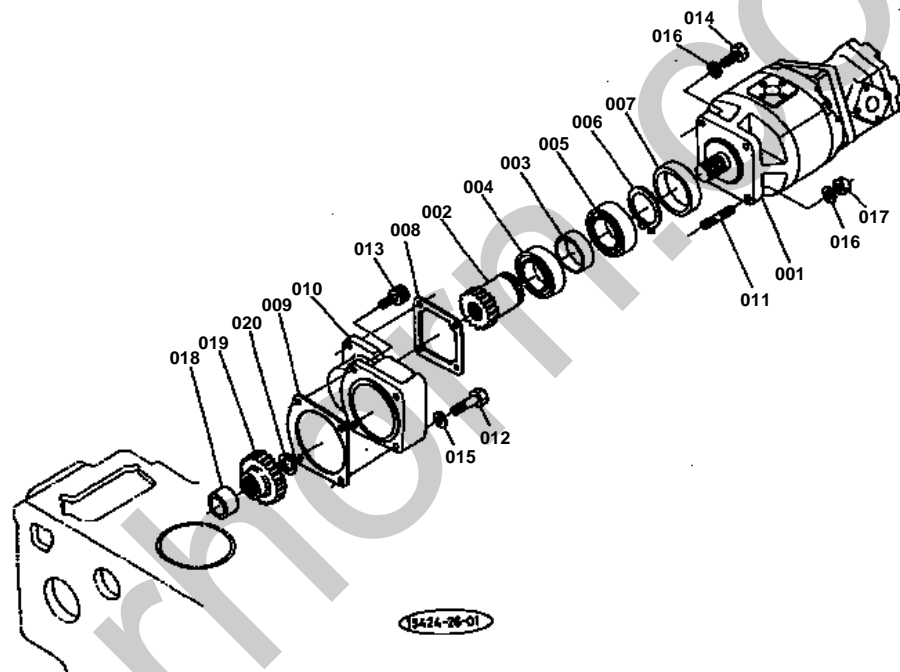



OIL HYDRAULIC PUMP

↔ Interchangeable; ≠ not interchangeable; ← new for old; → old for new

REF.No	Part No.	Description	Q'ty	S.No.	I/C	REMARKS	Weight (kgf)	Weight (lb)
001	35370-36100	PUMP,OIL PRESSURE	1				5.6	12.32
002	35370-37830	GEAR HELICAL 21	1				0.24	0.528
003	37300-37770	RACE,INNER	1				0.07	0.154
004	37300-37780	BEARING,NEEDLE	1				0.11	0.242
005	08101-06907	BEARING,BALL	1				0.073	0.1606
006	04612-00350	CIR-CLIP,INTERNAL	1				0.01	0.022
007	37300-37790	COLLAR	1				0.025	0.055
008	34150-37870	GASKET	1				0	0
009	19222-83110	GASKET	1				0	0
010	35370-37850	HOLDER,PUMP OIL PRES	1				1.54	3.388
011	01513-50820	STUD	2				0	0
012	01173-51050	BOLT	2				0.035	0.077
013	15471-91430	BOLT	2				0.035	0.077
014	01153-50822	BOLT	2				0.011	0.0242
015	04512-50100	WASHER,SPRING	2				0	0
016	04512-50080	WASHER,SPRING	4				0.001	0.0022
017	02156-50080	NUT	2				0.004	0.0088
018	35370-37820	COLLAR	1				0.015	0.033
019	35370-37810	GEAR 46	1				0.345	0.759
020	15471-95360	CIR-CLIP,INTERNAL	1				0.004	0.0088

OIL HYDRAULIC PUMP SECTION PARTS

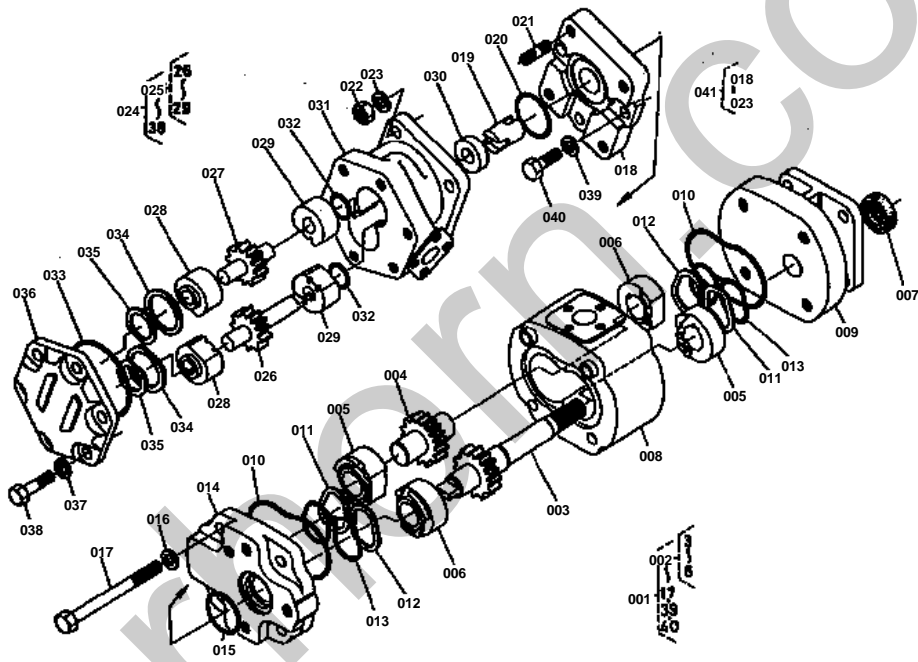



OIL HYDRAULIC PUMP SECTION PARTS

↔ Interchangeable; ≠ not interchangeable; ← new for old; → old for new

REF.No	Part No.	Description	Q'ty	S.No.	I/C	REMARKS	Weight (kgf)	Weight (lb)
001	35370-45110	PUMP,OIL PRESSURE 1	1				2.8	6.16
002	35370-36200	ASSY BUSH,GEAR	1				0.69	1.518
003	99999-99999	BLANK	0			ORDER BY REF.No.002	0	0
004	99999-99999	BLANK	0			ORDER BY REF.No.002	0	0
005	99999-99999	BLANK	0			ORDER BY REF.No.002	0	0
006	99999-99999	BLANK	0			ORDER BY REF.No.002	0	0
007	35320-36230	SEAL,OIL	1				0.005	0.011
008	35370-36110	BODY	1				0	0
009	99999-99999	BLANK	1			ORDER BY REF.No.001	0	0
010	35320-36260	SEAL,BODY	2				0.005	0.011
011	35320-36220	RING,GASKET L	2				0.001	0.0022
012	35320-36250	RING,GASKET R	2				0.002	0.0044
013	35320-36240	SEAL,BUSH	2				0.005	0.011
014	35340-36310	PLATE,CENTER	1				0.374	0.8228
015	04811-50300	O RING	1				0.001	0.0022
016	04512-50100	WASHER,SPRING	4				0	0
017	35320-36310	BOLT	4				0.055	0.121
018	35340-45130	PLATE,ADAPTER	1				0.66	1.452
019	35340-45140	COUPLING	1				0.032	0.0704
020	04811-50300	O RING	1				0.001	0.0022
021	35340-45150	STUD	4				0.01	0.022
022	02114-50080	NUT	4				0.005	0.011
023	04512-50080	WASHER,SPRING	4				0.001	0.0022
024	35340-45200	PUMP,OIL PRESSURE 2	1				1.89	4.158
025	35340-45210	ASSY BUSH,GEAR	1				0.56	1.232
026	99999-99999	BLANK	0			ORDER BY REF.No.025	0	0
027	99999-99999	BLANK	0			ORDER BY REF.No.025	0	0
028	99999-99999	BLANK	0			ORDER BY REF.No.025	0	0
029	99999-99999	BLANK	0			ORDER BY REF.No.025	0	0
030	35340-45250	SEAL,OIL	1				0.005	0.011
031	35340-45260	BODY	1				0.76	1.672
032	32270-36260	O RING	2				0.001	0.0022
033	32270-36220	O RING	1				0.001	0.0022
034	32270-36250	RING,SEALING	2				0.001	0.0022
035	32270-36240	RING,SUPPORT	2				0.005	0.011
036	37150-36180	COVER	1				0.25	0.55
037	04512-50080	WASHER,SPRING	6				0.001	0.0022
038	01156-50825	BOLT	6				0.013	0.0286
039	04512-50080	WASHER,SPRING	3				0.001	0.0022
040	01156-50825	BOLT	3				0.013	0.0286
041	35340-45120	ASSY ADAPTER	1				0.75	1.65

AIR CLEANER SUPPORT

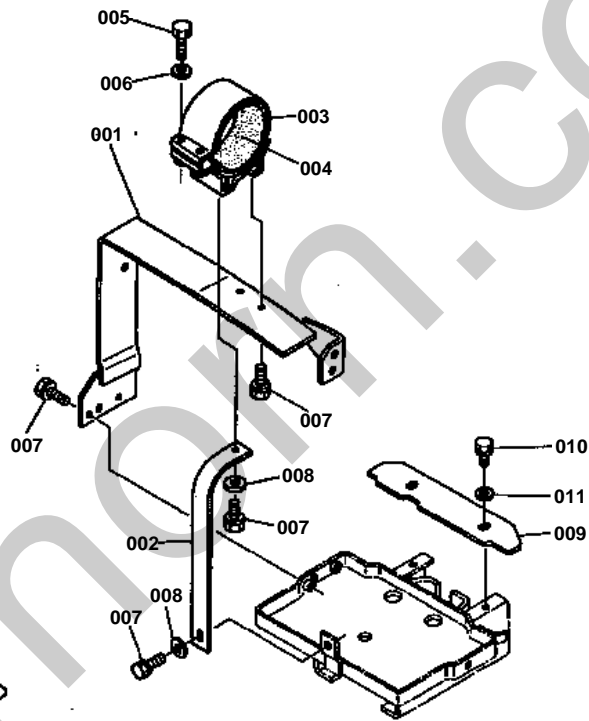



AIR CLEANER SUPPORT

↔ Interchangeable; ≠ not interchangeable; ← new for old; → old for new

REF.No	Part No.	Description	Q'ty	S.No.	I/C	REMARKS	Weight (kgf)	Weight (lb)
001	35340-13910	SUPPORT,AIR CLEANER	1				2.3	5.06
002	35340-13920	STAY,A/C SUPPORT	1				0.66	1.452
003	34260-13960	BAND,AIR CLEANER	1				0.675	1.485
004	34260-13970	CUSHION,AIR CLEANER	1				0.065	0.143
005	01150-50838	BOLT	2				0.017	0.0374
006	04512-50080	WASHER,SPRING	2				0.001	0.0022
007	01120-50820	BOLT	7				0	0
008	04012-50080	WASHER,PLAIN	2				0.001	0.0022
009	35340-13710	PLATE,SHUTTER	1				0.435	0.957
010	01123-50818	BOLT	2				0.012	0.0264
011	04015-50080	WASHER,PLAIN	2				0	0

FLYWHEEL HOUSING

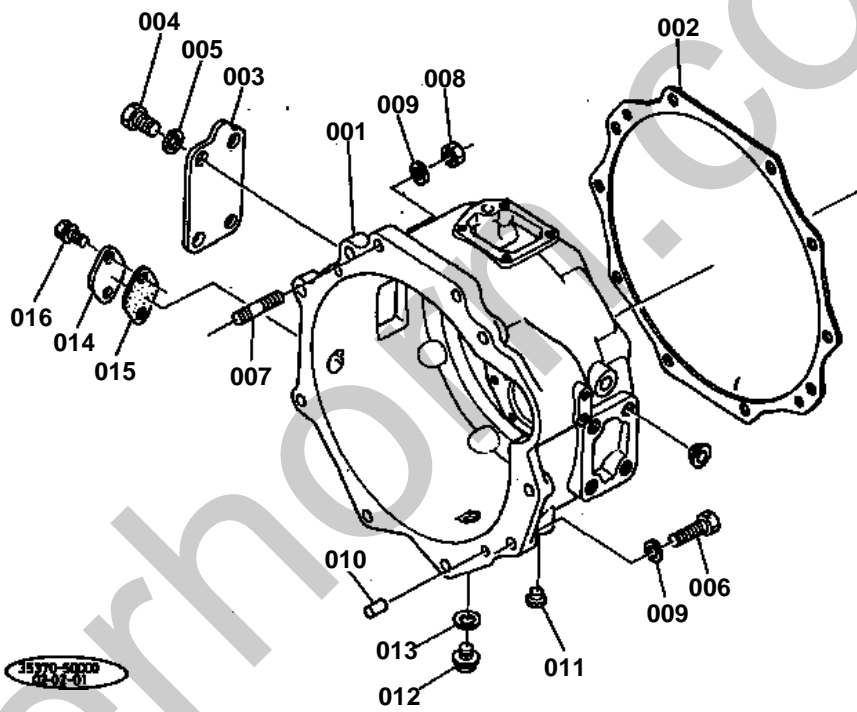



FLYWHEEL HOUSING

↔ Interchangeable; ≠ not interchangeable; ← new for old; → old for new

REF.No	Part No.	Description	Q'ty	S.No.	I/C	REMARKS	Weight (kgf)	Weight (lb)
001	35370-14100	HOUSING,FLYWHEEL	1				0	0
002	35370-13910	PACKING	1				0.015	0.033
003	35370-13920	COVER	1				0.18	0.396
004	01170-51425	BOLT	4				0.045	0.099
005	04512-50140	WASHER,SPRING	4				0	0
006	01173-51242	BOLT	8				0.047	0.1034
007	01574-51260	STUD	2				0	0
008	02174-50120	NUT	2				0.01	0.022
009	04512-50120	WASHER,SPRING	10				0	0
010	05012-01020	PIN,STRAIGHT	2				0.02	0.044
011	32210-27580	PLUG,BLIND	2				0.001	0.0022
012	06311-55010	PLUG	1				0.015	0.033
013	04717-01000	WASHER,SEAL	1				0.001	0.0022
014	15521-04680	COVER	1				0.035	0.077
015	15521-04790	PACKING,COVER	1				0.005	0.011
016	01123-50816	BOLT	2				0.011	0.0242

CLUTCH HOUSING

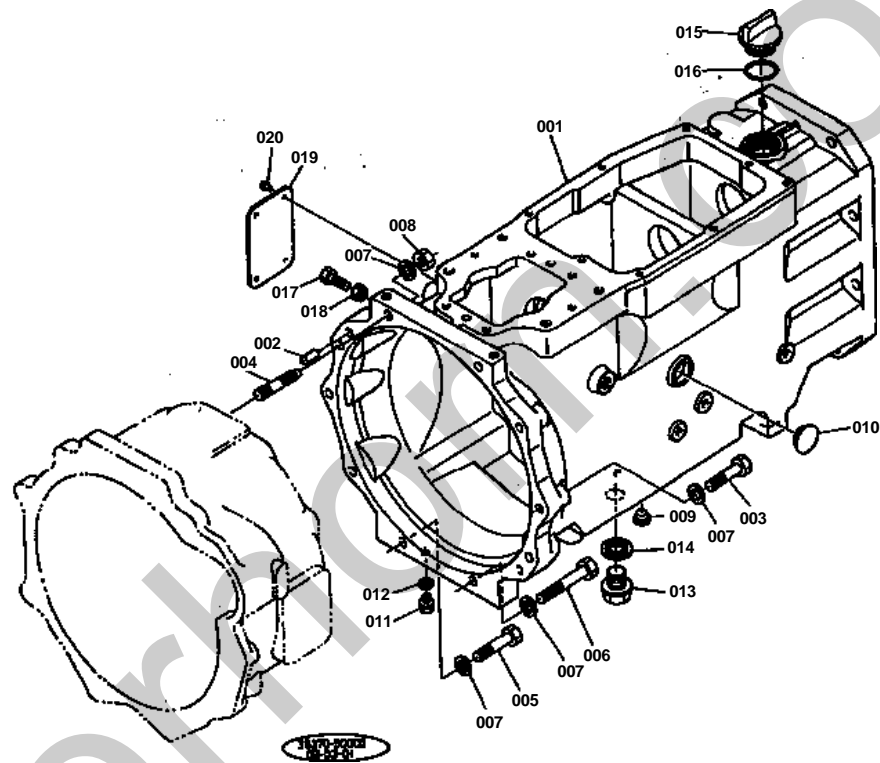



CLUTCH HOUSING

↔ Interchangeable; ≠ not interchangeable; ← new for old; → old for new

REF.No	Part No.	Description	Q'ty	S.No.	I/C	REMARKS	Weight (kgf)	Weight (lb)
001	35370-14110	HOUSING,CLUTCH	1				49	107.8
002	05012-01018	PIN,STRAIGHT	2				0.012	0.0264
003	01173-51240	BOLT	2				0.045	0.099
004	35340-14180	STUD	2				0	0
005	01173-51250	BOLT	5				0.053	0.1166
006	01173-51270	BOLT	1				0.067	0.1474
007	04512-50120	WASHER,SPRING	10				0	0
008	35340-27360	NUT	2				0.015	0.033
009	32210-27580	PLUG,BLIND	8				0.001	0.0022
010	38240-14210	GAUGE,OIL	1				0.01	0.022
011	06311-55010	PLUG	2				0.015	0.033
012	04717-01000	WASHER,SEAL	2				0.001	0.0022
013	34150-14260	PLUG,DRAIN	1				0	0
014	04717-02150	WASHER,SEAL	1				0.004	0.0088
015	38430-21410	PLUG	1				0.045	0.099
016	04811-50300	O RING	1				0.001	0.0022
017	01150-50825	BOLT	1				0	0
018	02114-50080	NUT	1				0.005	0.011
019	35260-19830	PLATE,NAME	1				0.015	0.033
020	34152-57920	RIVET	4				0.001	0.0022

OIL HYDRAULIC MANIFOLD

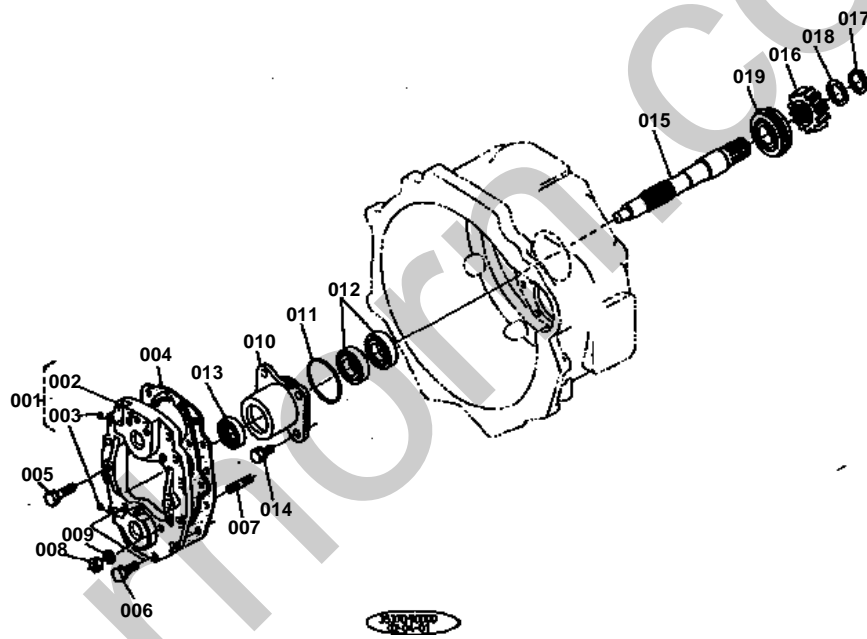



OIL HYDRAULIC MANIFOLD

↔ Interchangeable; ≠ not interchangeable; ← new for old; → old for new

REF.No	Part No.	Description	Q'ty	S.No.	I/C	REMARKS	Weight (kgf)	Weight (lb)
001	35370-13800	ASSY,O/P MANIFOLD	1				2.7	5.94
002	35370-13810	MANIFOLD,O/P	1				0	0
003	07715-03207	BALL	2				0.001	0.0022
004	35370-13820	PACKING	1				0.02	0.044
005	01123-50838	BOLT	2				0.02	0.044
006	01123-50828	BOLT	14				0.014	0.0308
007	01513-50822	STUD	2				0.01	0.022
008	02114-50080	NUT	2				0.005	0.011
009	04512-50080	WASHER,SPRING	2				0.001	0.0022
010	35370-13830	CASE,PROP.SHAFT	1				0.73	1.606
011	04811-50650	O RING	1				0.002	0.0044
012	08101-06005	BEARING,BALL	2				0.08	0.176
013	09500-25408	SEAL,OIL	1				0.01	0.022
014	01133-51020	BOLT	4				0.02	0.044
015	35370-13840	SHAFT,MAIN 1	1				0.85	1.87
016	35370-13880	GEAR,SPUR 18	1				0.32	0.704
017	38430-21550	CIR-CLIP,EXTERNAL	1				0.005	0.011
018	35370-13870	WASHER	1				0.005	0.011
019	35260-23110	BEARING,BALL	1				0.235	0.517

CLUTCH SHAFT UPPER

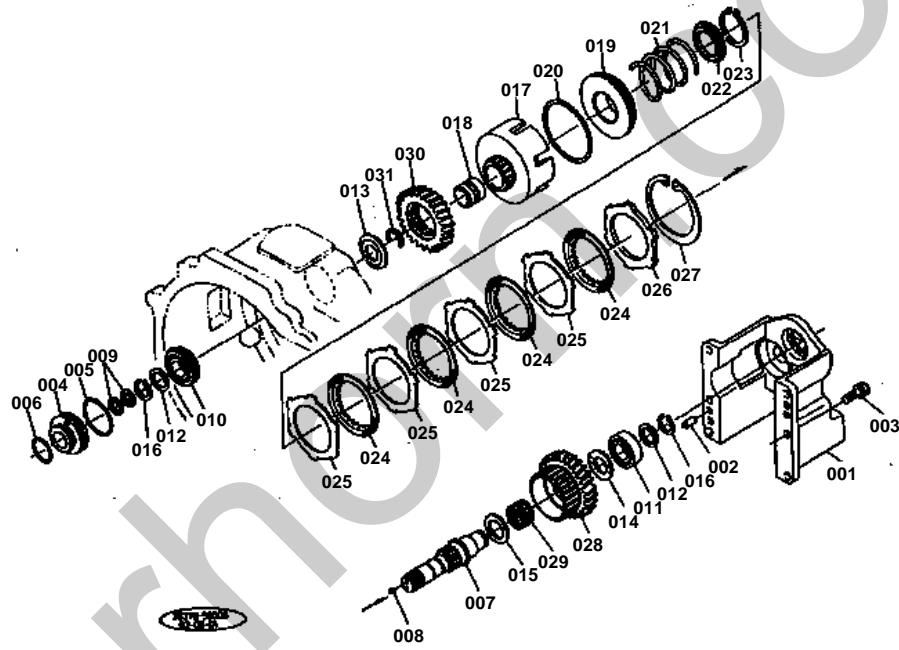



CLUTCH SHAFT UPPER

↔ Interchangeable; ≠ not interchangeable; ← new for old; → old for new

REF.No	Part No.	Description	Q'ty	S.No.	I/C	REMARKS	Weight (kgf)	Weight (lb)
001	35370-14350	CASE,GEAR	1				4.8	10.56
002	05012-01018	PIN,STRAIGHT	2				0.012	0.0264
003	01133-51028	BOLT	6				0.027	0.0594
004	35370-14120	CASE,SEAL	2				0.245	0.539
005	04811-50550	O RING	2				0.002	0.0044
006	04811-10360	O RING	2				0.001	0.0022
007	35370-14130	SHAFT,CLUTCH	1				0.73	1.606
008	03410-50606	SCREW,SET	1				0.001	0.0022
009	35370-14140	RING,SEAL	2				0.01	0.022
010	38280-21690	BEARING,BALL	1				0.135	0.297
011	67311-14520	BEARING,BALL	1				0.125	0.275
012	35370-13870	WASHER	2				0.005	0.011
013	35370-14200	WASHER	1				0.06	0.132
014	35370-21760	COLLAR,THRUST	1				0.025	0.055
015	38430-25232	COLLAR,THRUST	1				0.02	0.044
016	38430-21550	CIR-CLIP,EXTERNAL	2				0.005	0.011
017	35370-14170	CASE,CLUTCH	1				1.325	2.915
018	35370-14180	RACE,INNER	1				0.12	0.264
019	35370-14190	PISTON	1				0.43	0.946
020	35370-14210	O RING	1				0.005	0.011
021	35370-14220	SPRING	1				0.105	0.231
022	35370-14230	WASHER	1				0.03	0.066
023	04612-00480	CIR-CLIP,EXTERNAL	1				0.002	0.0044
024	35370-14240	DISK,CLUTCH	4				0.06	0.132
025	35370-14250	PLATE,STEEL 1.6	4				0	0
026	35370-14260	PLATE,STEEL 3.5	1				0.095	0.209
027	35370-14270	CIR-CLIP,INTERNAL	1				0.05	0.11
028	35370-14280	GEAR,SPUR 30-78	1				1.095	2.409
029	08823-03520	BEARING,NEEDLE	1				0.03	0.066
030	35370-14290	GEAR 30	1				0.74	1.628
031	37150-21790	CIR-CLIP	1				0.001	0.0022

CLUTCH SHAFT LOWER

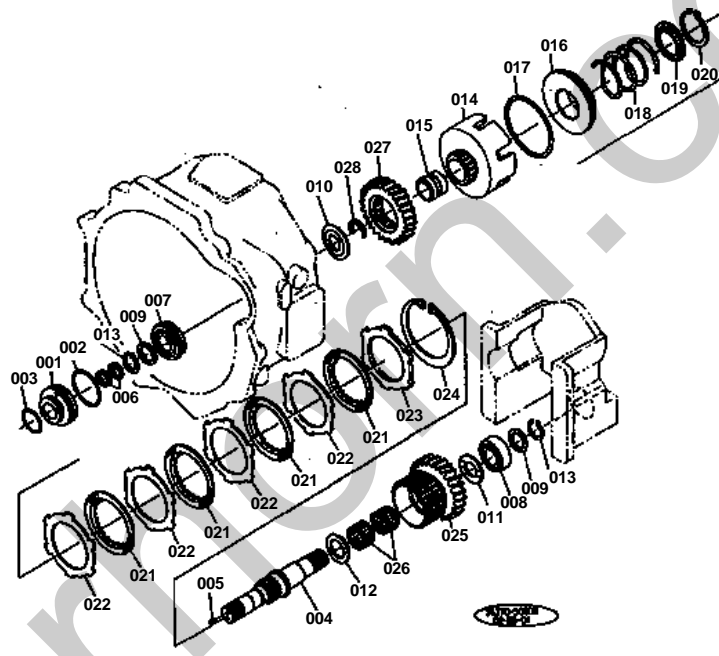



CLUTCH SHAFT LOWER

↔ Interchangeable; ≠ not interchangeable; ← new for old; → old for new

REF.No	Part No.	Description	Q'ty	S.No.	I/C	REMARKS	Weight (kgf)	Weight (lb)
001	35370-14120	CASE,SEAL	1				0.245	0.539
002	04811-50550	O RING	1				0.002	0.0044
003	04811-10360	O RING	1				0.001	0.0022
004	35370-14310	SHAFT,CLUTCH	1				0.935	2.057
005	03410-50606	SCREW,SET	1				0.001	0.0022
006	35370-14140	RING,SEAL	2				0.01	0.022
007	38280-21690	BEARING,BALL	1				0.135	0.297
008	67311-14520	BEARING,BALL	1				0.125	0.275
009	35370-13870	WASHER	2				0.005	0.011
010	35370-14200	WASHER	1				0.06	0.132
011	35370-21760	COLLAR,THRUST	1				0.025	0.055
012	38430-25232	COLLAR,THRUST	1				0.02	0.044
013	38430-21550	CIR-CLIP,EXTERNAL	2				0.005	0.011
014	35370-14170	CASE,CLUTCH	1				1.325	2.915
015	35370-14180	RACE,INNER	1				0.12	0.264
016	35370-14190	PISTON	1				0.43	0.946
017	35370-14210	O RING	1				0.005	0.011
018	35370-14220	SPRING	1				0.105	0.231
019	35370-14230	WASHER	1				0.03	0.066
020	04612-00480	CIR-CLIP,EXTERNAL	1				0.002	0.0044
021	35370-14240	DISK,CLUTCH	4				0.06	0.132
022	35370-14250	PLATE,STEEL 1.6	4				0	0
023	35370-14260	PLATE,STEEL 3.5	1				0.095	0.209
024	35370-14270	CIR-CLIP,INTERNAL	1				0.05	0.11
025	35370-14320	GEAR,SPUR 30-78 UNDE	1				1.335	2.937
026	08823-03520	BEARING,NEEDLE	2				0.03	0.066
027	35370-14290	GEAR,SPUR 30	1				0.74	1.628
028	37150-21790	CIR-CLIP	1				0.001	0.0022

REVERSE SHAFT

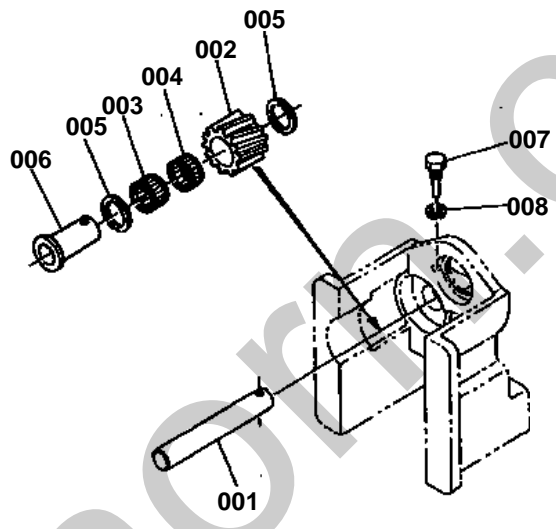

3570-8000
2637-01



REVERSE SHAFT

↔ Interchangeable; ≠ not interchangeable; ← new for old; → old for new

REF.No	Part No.	Description	Q'ty	S.No.	I/C	REMARKS	Weight (kgf)	Weight (lb)
001	35370-14370	SHAFT,REVERSE	1				0.35	0.77
002	35370-14360	GEAR,SPUR 15	1				0.29	0.638
003	08822-53020	BEARING,NEEDLE	1				0.023	0.0506
004	08822-53017	BEARING,NEEDLE	1				0.022	0.0484
005	35370-14330	COLLAR,THRUST	2				0.007	0.0154
006	35370-14340	RACE,INNER	1				0.095	0.209
007	37150-23120	SCREW,SET	1				0.02	0.044
008	04512-50080	WASHER,SPRING	1				0.001	0.0022

CLUTCH

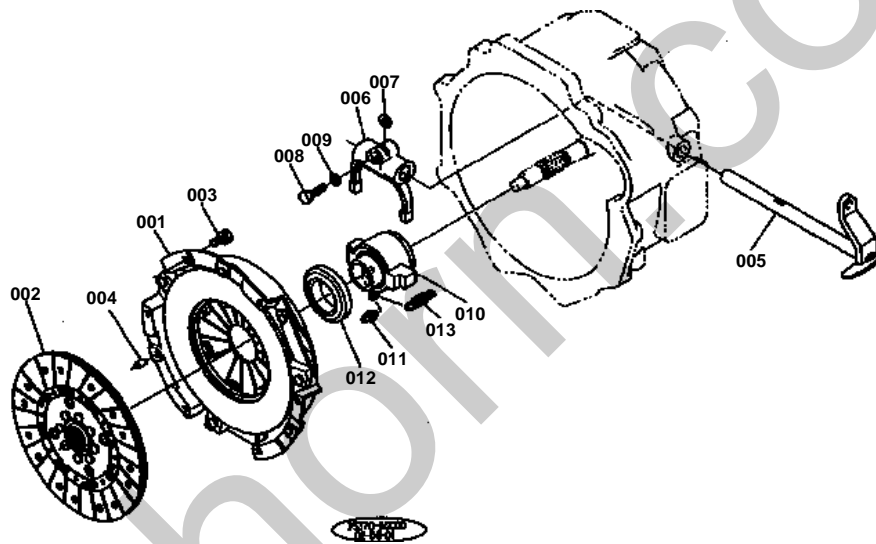



CLUTCH

↔ Interchangeable; ≠ not interchangeable; ← new for old; → old for new

REF.No	Part No.	Description	Q'ty	S.No.	I/C	REMARKS	Weight (kgf)	Weight (lb)
001	35370-14500	ASSY PLATE,PRESSURE	1				7.6	16.72
002	35370-14300	DISK,CLUTCH	1				0	0
003	01123-50816	BOLT	6				0.011	0.0242
004	05012-00612	PIN,SPLIT	3				0.003	0.0066
005	35370-14510	LEVER,CLUTCH 1	1				0.77	1.694
006	35370-14720	FORK,CLUTCH RELEASE	1				0.455	1.001
007	31150-14780	KEY,FORK	1				0.003	0.0066
008	01153-50828	BOLT	1				0.014	0.0308
009	04512-50080	WASHER,SPRING	1				0.001	0.0022
010	35370-14810	HUB,CLUTCH RELEASE	1				0.8	1.76
011	06613-20010	NIPPLE,GREASE	1				0.01	0.022
012	08490-00001	BEARING,THRUST BALL	1				0.227	0.4994
013	35370-14840	SPRING	1				0.005	0.011

CLUTCH PEDAL

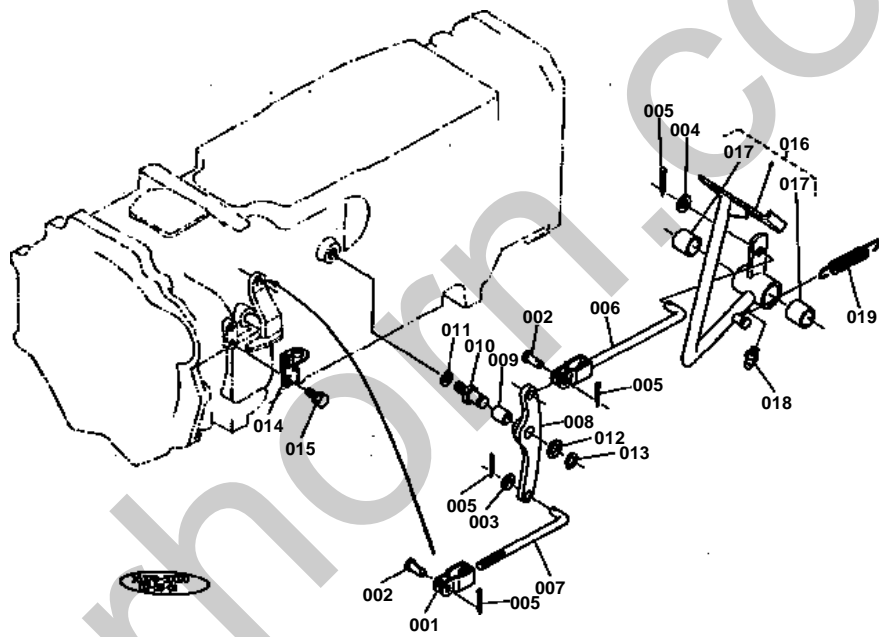



CLUTCH PEDAL

↔ Interchangeable; ≠ not interchangeable; ← new for old; → old for new

REF.No	Part No.	Description	Q'ty	S.No.	I/C	REMARKS	Weight (kgf)	Weight (lb)
001	38240-24360	JOINT,FORKED	1				0.08	0.176
002	05122-51022	PIN,JOINT	2				0.014	0.0308
003	04013-50100	WASHER,PLAIN	1				0	0
004	04013-50120	WASHER,PLAIN	1				0	0
005	05511-50318	PIN,SPLIT	4				0.001	0.0022
006	35370-15410	ROD,CLUTCH 1	1				0.265	0.583
007	35370-15420	ROD,CLUTCH 2	1				0.115	0.253
008	35370-15430	LEVER,CLUTCH 2	1				0.345	0.759
009	35370-15440	BUSH	1				0	0
010	35370-15450	SHAFT,CLUTCH LEVER	1				0.085	0.187
011	04512-50140	WASHER,SPRING	1				0	0
012	35370-15460	WASHER	1				0.025	0.055
013	04612-00160	CIR-CLIP,EXTERNAL	1				0.001	0.0022
014	35370-15470	BKT.SAFETY SWITCH	1				0.06	0.132
015	01120-50814	BOLT	2				0	0
016	35370-15710	PEDAL,CLUTCH	1				1.635	3.597
017	34150-28430	BUSH	2				0.04	0.088
018	06613-10675	NIPPLE,GREASE	1				0.003	0.0066
019	37150-15840	SPRING	1				0.06	0.132

HAND ACCELERATOR

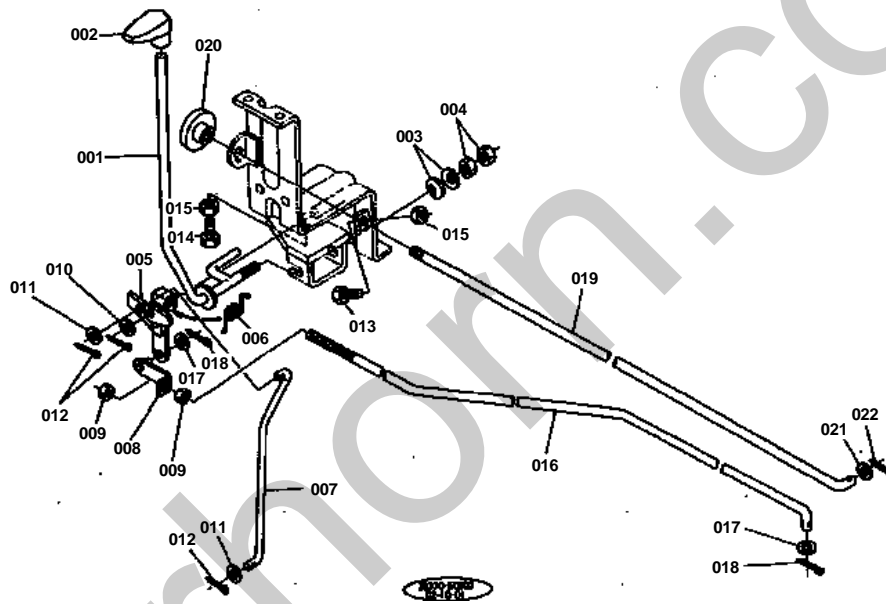



HAND ACCELERATOR

↔ Interchangeable; ≠ not interchangeable; ← new for old; → old for new

REF.No	Part No.	Description	Q'ty	S.No.	I/C	REMARKS	Weight (kgf)	Weight (lb)
001	35170-17120	LEVER,HAND ACCEL	1				0.345	0.759
002	35320-17170	GRIP,ACCELERATOR	1				0.018	0.0396
003	34260-17190	SPRING	2				0.002	0.0044
004	02118-50100	NUT	2				0.005	0.011
005	35260-17320	LINK,ACCELERATOR	1				0.1	0.22
006	34150-17260	SPRING	1				0.01	0.022
007	35340-17570	ROD,ACCELERATOR	1				0.07	0.154
008	34150-17390	JOINT,ROD	1				0.025	0.055
009	02012-50060	NUT	2				0	0
010	04012-50080	WASHER,PLAIN	1				0.001	0.0022
011	04012-50060	WASHER,PLAIN	4				0.001	0.0022
012	05511-50212	PIN,SPLIT	4				0.001	0.0022
013	01155-50840	BOLT	1				0.02	0.044
014	01152-50830	BOLT	1				0.014	0.0308
015	02112-50080	NUT	2				0.003	0.0066
016	35370-17360	ROD,ACCELERATOR	1				1.9	4.18
017	04012-50060	WASHER,PLAIN	2				0.001	0.0022
018	05511-50212	PIN,SPLIT	2				0.001	0.0022
019	35370-17150	ROD,STOP	1				0.2	0.44
020	35260-17160	KNOB	1				0.015	0.033
021	04012-50060	WASHER,PLAIN	1				0.001	0.0022
022	05511-50212	PIN,SPLIT	1				0.001	0.0022

HOOD 1

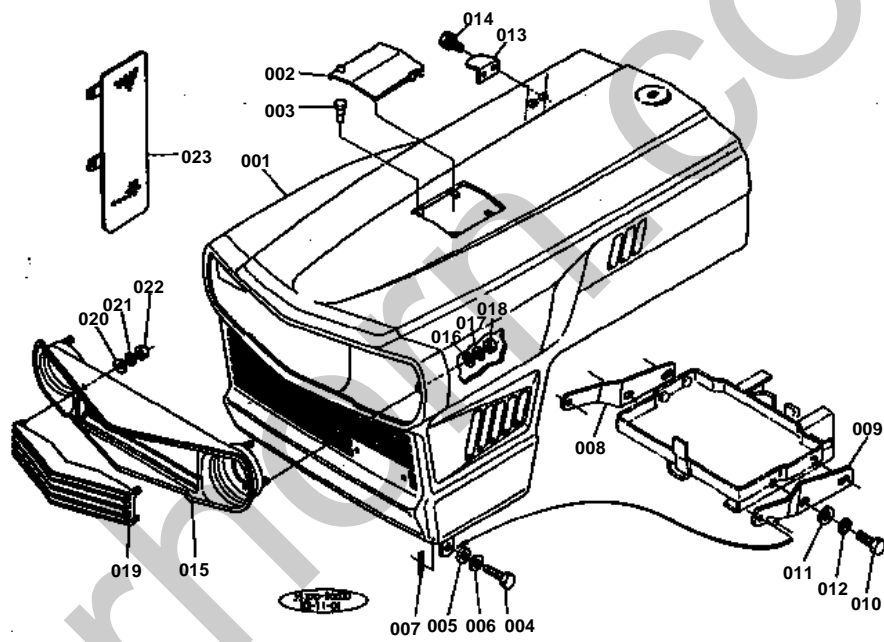

**HOOD 1**

↔ Interchangeable; ≠ not interchangeable; ← new for old; → old for new

REF.No	Part No.	Description	Q'ty	S.No.	I/C	REMARKS	Weight (kgf)	Weight (lb)
001	35340-18110	COMP,BONNET	1				16.5	36.3
002	37300-18120	COVER,BONNET	1				0.225	0.495
003	32280-18180	CUSHION	2				0.001	0.0022
004	34150-18170	BOLT	2				0.04	0.088
005	34150-18180	CUSHION	2				0.003	0.0066
006	04013-50120	WASHER,PLAIN	2				0	0
007	05511-50425	PIN,SPLIT	2				0.003	0.0066
008	37300-18140	LEG BONNET,RH	1				0.675	1.485
009	37300-18130	LEG BONNET,LH	1				0.65	1.43
010	01170-51230	BOLT	4				0	0
011	04015-50120	WASHER,PLAIN	4				0	0
012	04512-50120	WASHER,SPRING	4				0	0
013	37300-18170	HOOK	1				0.06	0.132
014	01202-50616	BOLT	2				0.006	0.0132
015	35370-18150	GRILLE,LIGHT OUTER	1				0.96	2.112
016	04015-50050	WASHER,PLAIN	4				0.004	0.0088
017	04512-50050	WASHER,SPRING	4				0	0
018	02054-50050	NUT	4				0.002	0.0044
019	35370-18160	GRILLE,LIGHT INNER	1				0.195	0.429
020	04012-50060	WASHER,PLAIN	4				0.001	0.0022
021	04512-50060	WASHER,SPRING	4				0	0
022	02014-50060	NUT	4				0.003	0.0066
023	35370-13850	COVER,FAN	1				0.37	0.814

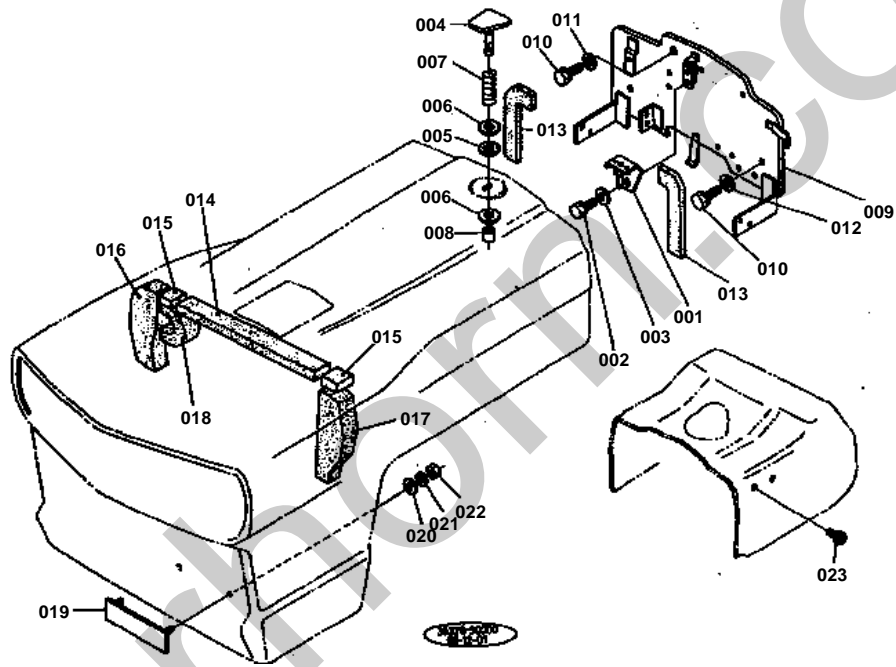

**HOOD 2**

↔ Interchangeable; ≠ not interchangeable; ← new for old; → old for new

REF.No	Part No.	Description	Q'ty	S.No.	I/C	REMARKS	Weight (kgf)	Weight (lb)
001	37300-18220	HOLDER,BONNET	1				0.125	0.275
002	01120-50818	BOLT	2				0	0
003	04013-50080	WASHER,PLAIN	2				0	0
004	33251-83460	PIN,BONNET	1				0.045	0.099
005	04711-00100	PACKING	1				0.001	0.0022
006	04013-50100	WASHER,PLAIN	2				0	0
007	34150-37740	SPRING	1				0.003	0.0066
008	33251-83480	SPACER	1				0.001	0.0022
009	35370-18060	PLATE,SHUTTER	1				2.2	4.84
010	01120-50816	BOLT	3				0	0
011	04015-50080	WASHER,PLAIN	1				0	0
012	04012-50080	WASHER,PLAIN	2				0.001	0.0022
013	38430-18040	CUSHION	2				0.01	0.022
014	37300-18020	CUSHION,UPPER 1	1				0.02	0.044
015	37300-18030	CUSHION,UPPER 2	2				0.002	0.0044
016	35370-18040	CUSHION RH,SIDE	1				0	0
017	35370-18050	CUSHION,LH,SIDE	1				0	0
018	37300-18080	CUSHION,CENTER	1				0.01	0.022
019	32240-18260	MARK,FRONT KUBOTA	1				0.027	0.0594
020	04013-50050	WASHER,PLAIN	2				0	0
021	04512-50050	WASHER,SPRING	2				0	0
022	02054-50050	NUT	2				0.002	0.0044
023	03004-50812	SCREW,WITH WASHER	8				0.008	0.0176

TRANSMISSION CASE

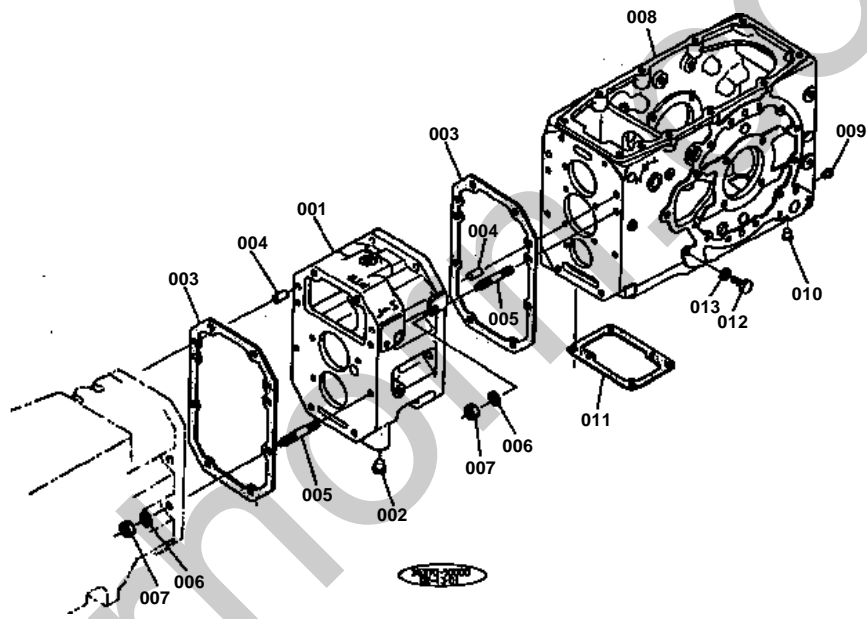



TRANSMISSION CASE

↔ Interchangeable; ≠ not interchangeable; ← new for old; → old for new

REF.No	Part No.	Description	Q'ty	S.No.	I/C	REMARKS	Weight (kgf)	Weight (lb)
001	35370-14150	CASE,MID	1				14.75	32.45
002	32210-27580	PLUG,BLIND	2				0.001	0.0022
003	35340-14140	PACKING	2				0.01	0.022
004	05012-01018	PIN,STRAIGHT	4				0.012	0.0264
005	35340-14180	STUD	16				0	0
006	04512-50120	WASHER,SPRING	16				0	0
007	35340-27360	NUT	16				0.015	0.033
008	35340-21114	CASE,TRANSMISSION	1				26.5	58.3
009	32210-27580	PLUG,BLIND	10				0.001	0.0022
010	31220-14290	PLUG	6				0.002	0.0044
011	37150-21282	PACKING	1				0	0
012	01222-50816	BOLT	1				0.01	0.022
013	04512-50080	WASHER,SPRING	1				0.001	0.0022

MAIN SHAFT

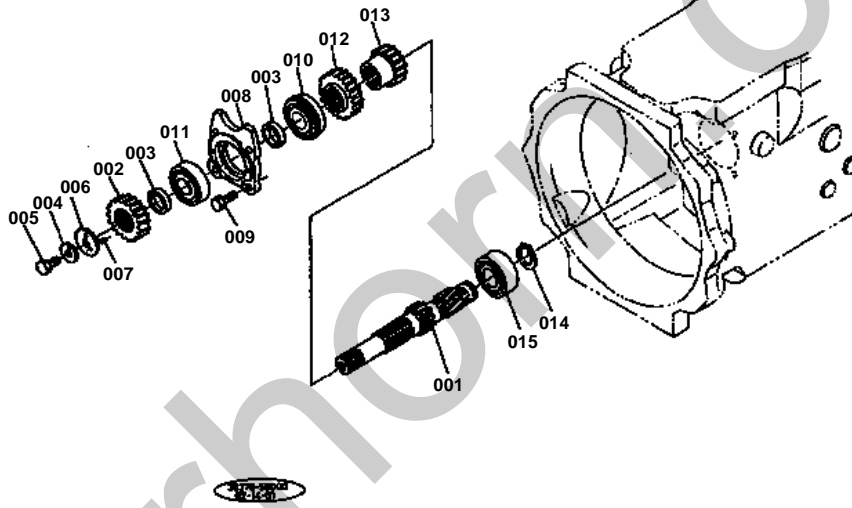



MAIN SHAFT

↔ Interchangeable; ≠ not interchangeable; ← new for old; → old for new

REF.No	Part No.	Description	Q'ty	S.No.	I/C	REMARKS	Weight (kgf)	Weight (lb)
001	35370-21410	SHAFT,MAIN 2	1				1.235	2.717
002	35370-13880	GEAR,SPUR 18	1				0.32	0.704
003	35370-21430	COLLAR	2				0.035	0.077
004	38180-22370	WASHER,CLAW	1				0.005	0.011
005	34260-26260	BOLT	1				0.03	0.066
006	34260-21590	WASHER	1				0.04	0.088
007	05012-00310	PIN,STRAIGHT	1				0.001	0.0022
008	35370-21440	CASE,BEARING	1				0.565	1.243
009	01123-51030	BOLT	4				0.025	0.055
010	35260-23110	BEARING,BALL	1				0.235	0.517
011	36340-41290	BEARING	1				0.235	0.517
012	35340-21532	GEAR,SPUR 24	1				0.405	0.891
013	35370-21450	GEAR,SPUR 20	1				0.29	0.638
014	04612-00300	CIR-CLIP,EXTERNAL	1				0.003	0.0066
015	08241-03206	BEARING,BALL	1				0.302	0.6644

COUNTER SHAFT

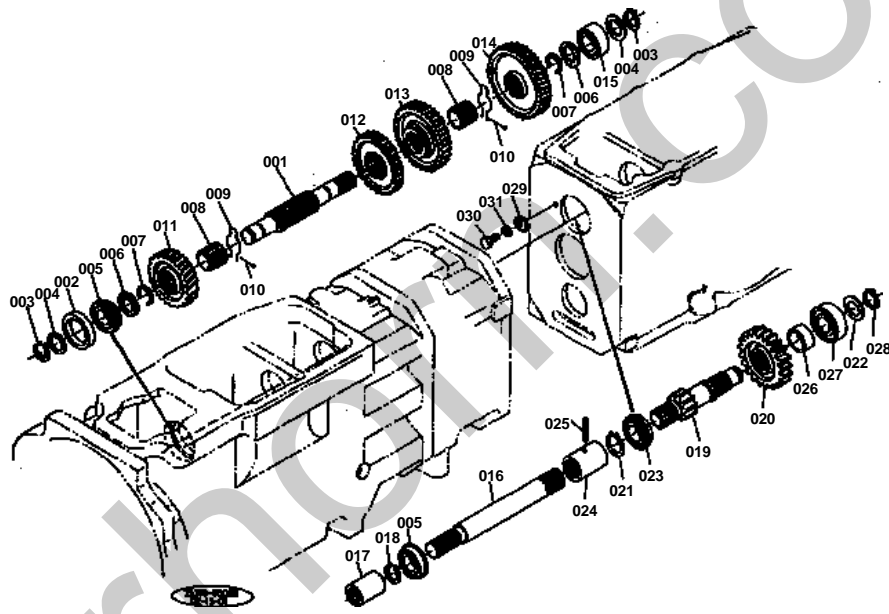



COUNTER SHAFT

↔ Interchangeable; ≠ not interchangeable; ← new for old; → old for new

REF.No	Part No.	Description	Q'ty	S.No.	I/C	REMARKS	Weight (kgf)	Weight (lb)
001	35300-21610	COUNTERSHAFT	1				1.115	2.453
002	35370-21510	COLLAR	1				0.09	0.198
003	37150-21550	CIR-CLIP,EXTERNAL	2				0.06	0.132
004	34150-21560	WASHER	2				0.01	0.022
005	08151-06205	BEARING,BALL	2				0.131	0.2882
006	37150-21760	COLLAR,THRUST	2				0.017	0.0374
007	37150-21790	CIR-CLIP	2				0.001	0.0022
008	37150-21750	BOSS,SPLINE	2				0.088	0.1936
009	35340-21782	CIR-CLIP	2				0.007	0.0154
010	35340-21792	WIRE	2				0.001	0.0022
011	35340-21712	GEAR,SPUR 31	1				0.535	1.177
012	35370-21720	GEAR,SPUR 38	1				0.67	1.474
013	35370-21730	GEAR,SPUR 44	1				0.9	1.98
014	37150-21740	GEAR,SPUR 45	1				1.08	2.376
015	08241-03205	BEARING,BALL	1				0	0
016	35340-21810	SHAFT,CREEP S-CHANGE	1				1.43	3.146
017	35300-21660	COUPLING	1				0.19	0.418
018	37150-21550	CIR-CLIP,EXTERNAL	1				0.06	0.132
019	35370-21910	SHAFT,13 GEAR	1				0.98	2.156
020	35370-21920	GEAR,SPUR 22	1				0.67	1.474
021	04612-00300	CIR-CLIP,EXTERNAL	1				0.003	0.0066
022	34150-21560	WASHER	1				0.01	0.022
023	08151-06206	BEARING,BALL	1				0.2	0.44
024	37300-21680	COUPLING	1				0.28	0.616
025	05411-00540	PIN,SPRING	1				0.004	0.0088
026	37300-21940	COLLAR,DISTANCE	1				0.055	0.121
027	08101-06305	BEARING,BALL	1				0.23	0.506
028	37150-21550	CIR-CLIP,EXTERNAL	1				0.06	0.132
029	34150-21942	RETAINER,BEARING	1				0.035	0.077
030	01153-50820	BOLT	1				0.012	0.0264
031	04512-50080	WASHER,SPRING	1				0.001	0.0022

PTO COUNTER SHAFT

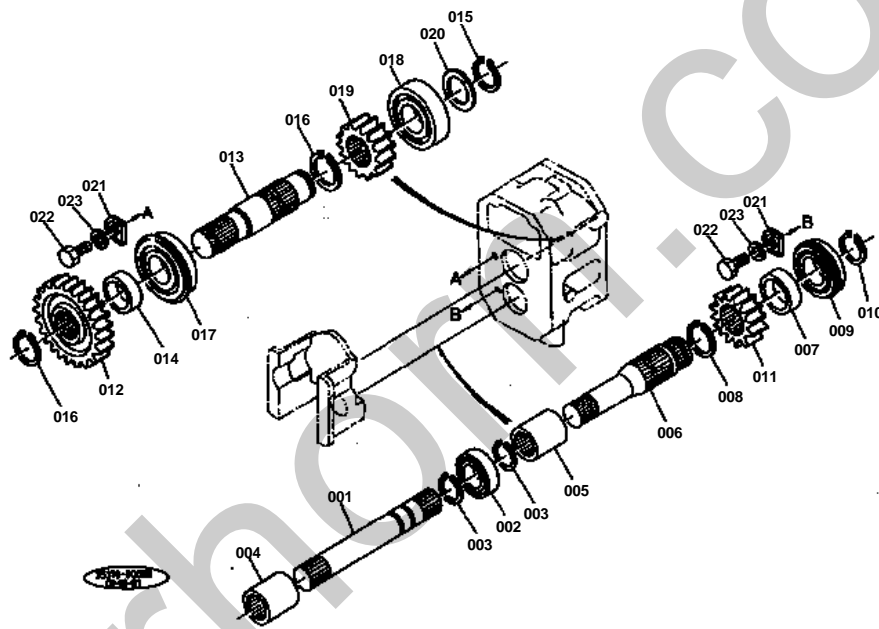



PTO COUNTER SHAFT

↔ Interchangeable; ≠ not interchangeable; ← new for old; → old for new

REF.No	Part No.	Description	Q'ty	S.No.	I/C	REMARKS	Weight (kgf)	Weight (lb)
001	35370-25330	SHAFT,COUNTER (PTO)	1				0.785	1.727
002	08101-06205	BEARING,BALL	1				0.14	0.308
003	04612-00250	CIR-CLIP,EXTERNAL	2				0.002	0.0044
004	37150-21680	COUPLING	1				0	0
005	37150-21680	COUPLING	1				0	0
006	35370-25250	SHAFT,COUNTER (PTO)	1				0.86	1.892
007	35340-25260	COLLAR	1				0.043	0.0946
008	04612-00350	CIR-CLIP,EXTERNAL	1				0.01	0.022
009	08150-00008	BEARING,BALL	1				0.225	0.495
010	38430-25540	CIR-CLIP,EXTERNAL	1				0.004	0.0088
011	35370-25270	GEAR 14	1				0.255	0.561
012	35370-25280	GEAR 23	1				0.94	2.068
013	35370-25290	SHAFT,GEAR (PTO)	1				0.965	2.123
014	35340-25210	COLLAR	1				0.06	0.132
015	38430-25540	CIR-CLIP,EXTERNAL	2				0.004	0.0088
016	04612-00350	CIR-CLIP,EXTERNAL	1				0.01	0.022
017	38450-25340	BEARING,BALL	1				0.365	0.803
018	38450-25350	BEARING,BALL	1				0.345	0.759
019	35370-25230	GEAR 14	1				0.33	0.726
020	35340-21760	COLLAR,THRUST	1				0.01	0.022
021	34150-21942	RETAINER,BEARING	2				0.035	0.077
022	01153-50820	BOLT	2				0.012	0.0264
023	04512-50080	WASHER,SPRING	2				0.001	0.0022

SPIRAL BEVEL PINION

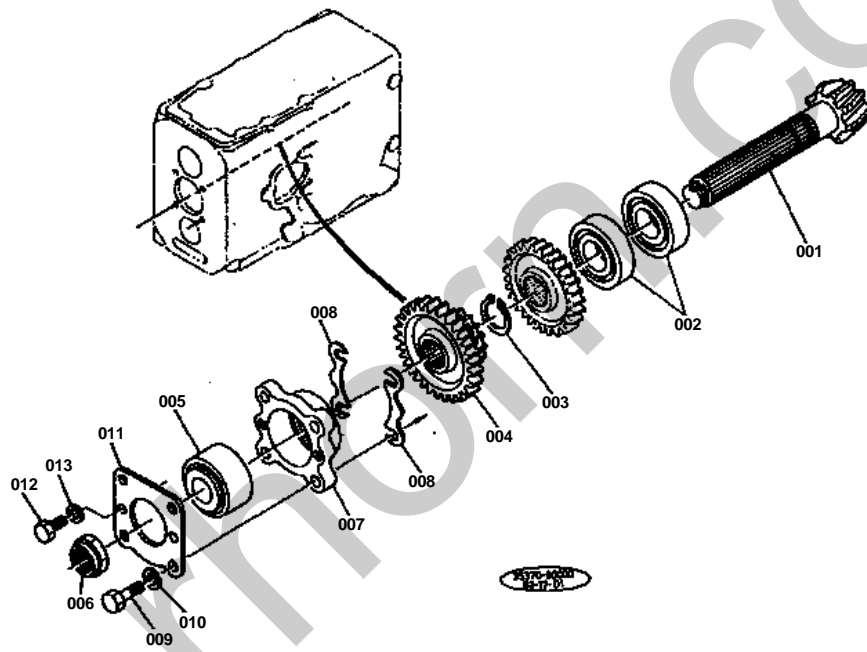



SPIRAL BEVEL PINION

↔ Interchangeable; ≠ not interchangeable; ← new for old; → old for new

REF.No	Part No.	Description	Q'ty	S.No.	I/C	REMARKS	Weight (kgf)	Weight (lb)
001	99999-99999	BLANK	0			ORDER BY REF.No.021 ON L.No.0C12-R0	0	0
002	08641-00306	BEARING,ROLLER	2				0.37	0.814
003	04612-00300	CIR-CLIP,EXTERNAL	1				0.003	0.0066
004	35370-21950	GEAR,SPUR 14-37	1				1.1	2.42
005	38240-22140	BEARING,TAPER ROLLER	1				0.56	1.232
006	31220-22340	NUT 22	1				0.033	0.0726
007	37300-22150	CASE,BEARING	1				0.56	1.232
008	34150-22610	SHIM 0.5	2				0.01	0.022
008	34150-22620	SHIM 0.2	4				0.005	0.011
008	34150-22630	SHIM 0.1	2				0.005	0.011
009	01173-51035	BOLT	4				0.025	0.055
010	04512-50100	WASHER,SPRING	4				0	0
011	34150-22170	COVER,BEARING	1				0.16	0.352
012	01153-50816	BOLT	2				0.01	0.022
013	04512-50080	WASHER,SPRING	2				0.001	0.0022

POWER TAKE-OFF SHAFT

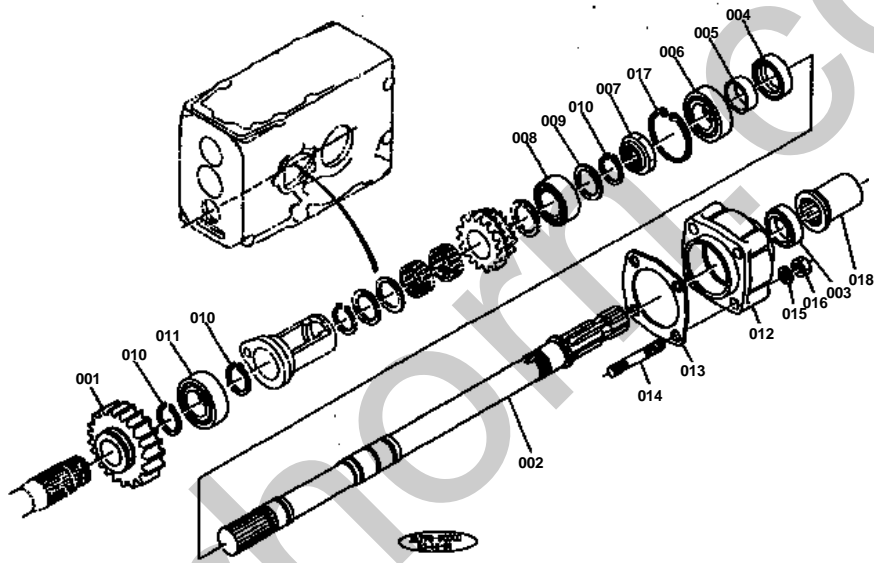



POWER TAKE-OFF SHAFT

↔ Interchangeable; ≠ not interchangeable; ← new for old; → old for new

REF.No	Part No.	Description	Q'ty	S.No.	I/C	REMARKS	Weight (kgf)	Weight (lb)
001	35370-25450	GEAR 23	1				1.1	2.42
002	35370-25310	SHAFT (PTO)	1				3.6	7.92
003	37150-25370	SLIDINGER	1				0.007	0.0154
004	35340-25360	SEAL,OIL	1				0.024	0.0528
005	35340-25350	COLLAR,OIL SEAL	1				0.03	0.066
006	08101-06232	BEARING,BALL	1				0.22	0.484
007	35340-25320	NUT	1				0.05	0.11
008	35340-25380	BEARING,ROLLER	1				0.175	0.385
009	35340-21760	COLLAR,THRUST	1				0.01	0.022
010	04612-00300	CIR-CLIP,EXTERNAL	3				0.003	0.0066
011	08241-03206	BEARING,BALL	1				0.302	0.6644
012	35370-25410	CASE,BEARING	1				2.1	4.62
013	37150-25420	GASKET	1				0	0
014	01513-50860	STUD	4				0.024	0.0528
015	04512-50080	WASHER,SPRING	4				0.001	0.0022
016	35320-25470	NUT	4				0.006	0.0132
017	04611-00650	CIR-CLIP,INTERNAL	1				0.011	0.0242
018	31220-25820	CAP	1				0.055	0.121

MAIN SHIFT LEVER

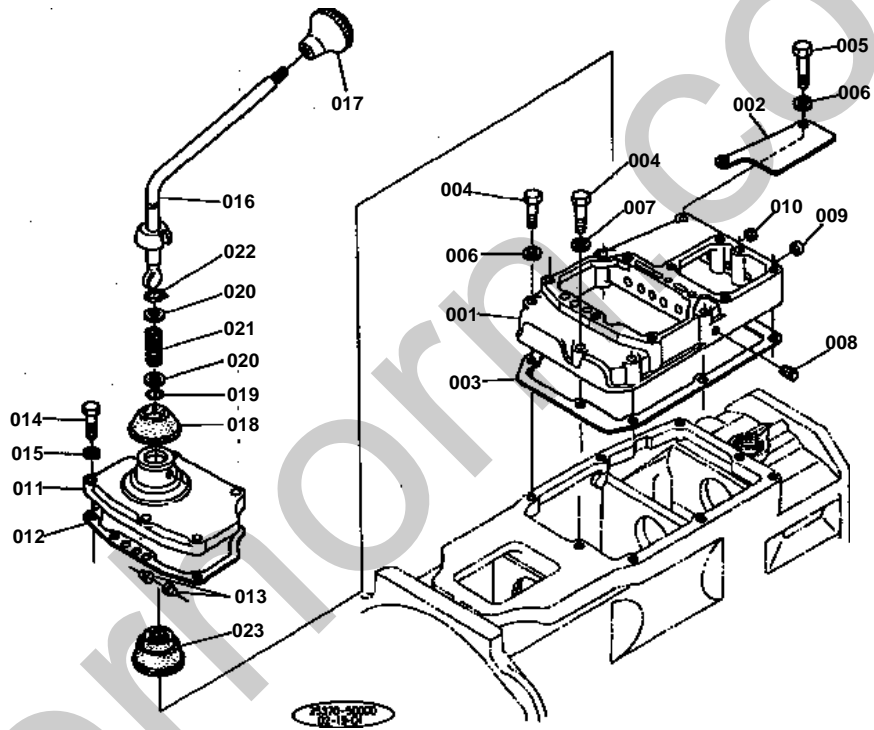



MAIN SHIFT LEVER

↔ Interchangeable; ≠ not interchangeable; ← new for old; → old for new

REF.No	Part No.	Description	Q'ty	S.No.	I/C	REMARKS	Weight (kgf)	Weight (lb)
001	37150-21210	COVER,SPEED CHANGE	1				1.14	2.508
002	35370-21220	PLATE,SPEED CHANGE	1				0.11	0.242
003	34650-59140	PACKING	1				0	0
004	01153-50840	BOLT	3				0.018	0.0396
005	01153-50850	BOLT	3				0.02	0.044
006	04512-50080	WASHER,SPRING	5				0.001	0.0022
007	04717-00800	WASHER,SEAL	1				0.001	0.0022
008	34150-23960	PLUG	2				0	0
009	34150-21250	PLUG	5				0.002	0.0044
010	34269-21250	PLUG	1				0	0
011	35340-23710	BASE,SPEED CHANGE	1				1.46	3.212
012	34150-23720	PACKING	1				0	0
013	34150-23740	PIN,SET	2				0.002	0.0044
014	01153-50832	BOLT	5				0.015	0.033
015	04512-50080	WASHER,SPRING	5				0.001	0.0022
016	34150-23810	LEVER,MAIN S-CHANGE	1				0.43	0.946
017	32150-23860	GRIP,LEVER	1				0.037	0.0814
018	34150-23940	SHIELD,LEVER	1				0.025	0.055
019	04811-00120	O RING	1				0.001	0.0022
020	32240-23950	WASHER	2				0.002	0.0044
021	32240-23920	SPRING	1				0.007	0.0154
022	31220-23930	CIR-CLIP,EXTERNAL	1				0.001	0.0022
023	38430-23870	SHIELD	1				0.018	0.0396

MAIN SHIFT FORK

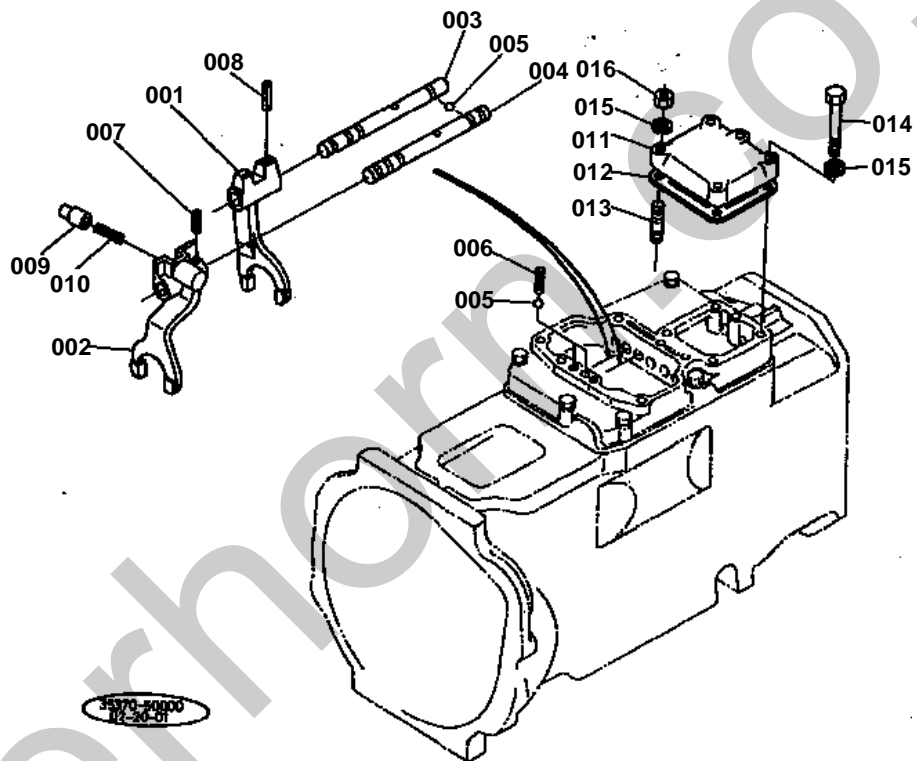



MAIN SHIFT FORK

↔ Interchangeable; ≠ not interchangeable; ← new for old; → old for new

REF.No	Part No.	Description	Q'ty	S.No.	I/C	REMARKS	Weight (kgf)	Weight (lb)
001	35260-23510	FORK,SHIFT	1				0.21	0.462
002	35305-23520	FORK,SHIFT	1				0.28	0.616
003	37150-23540	ROD,FORK	1				0.12	0.264
004	37150-23550	ROD,FORK	1				0.12	0.264
005	07715-01605	BALL	4				0.003	0.0066
006	62231-18530	SPRING,STOPPER	2				0.01	0.022
007	05411-00420	PIN,SPRING	1				0.001	0.0022
008	05411-00430	PIN,SPRING	1				0.002	0.0044
009	34150-23610	PIECE,NEUTRUL	1				0.015	0.033
010	34150-23620	SPRING	1				0.003	0.0066
011	35340-24830	COVER,CREEP S-CHANGE	1				0.468	1.0296
012	34650-59330	PACKING	1				0	0
013	01513-50825	STUD	3				0	0
014	01153-50870	BOLT	2				0.026	0.0572
015	04512-50080	WASHER,SPRING	5				0.001	0.0022
016	02156-50080	NUT	3				0.004	0.0088

HI-LO GEAR SHIFT LEVER

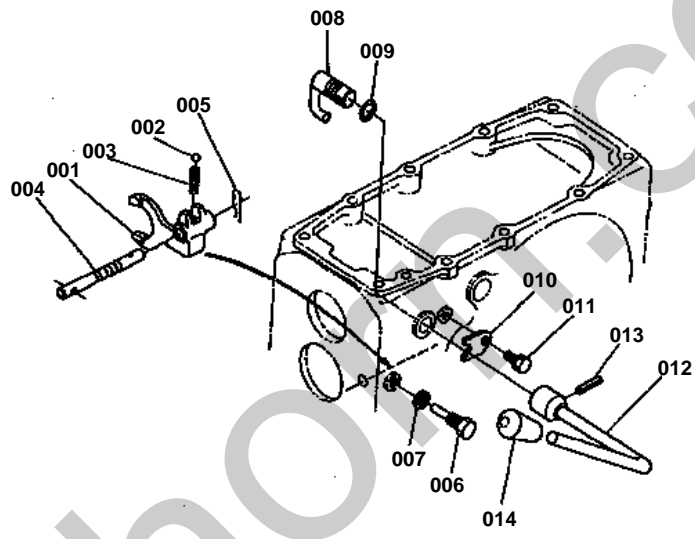



HI-LO GEAR SHIFT LEVER

↔ Interchangeable; ≠ not interchangeable; ← new for old; → old for new

REF.No	Part No.	Description	Q'ty	S.No.	I/C	REMARKS	Weight (kgf)	Weight (lb)
001	35300-24110	FORK,SHIFT	1				0.2	0.44
002	07715-01605	BALL	1				0.003	0.0066
003	62231-18530	SPRING,STOPPER	1				0.01	0.022
004	37150-24130	SHAFT,FORK	1				0.11	0.242
005	05515-51200	PIN,SNAP	1				0	0
006	37150-23120	SCREW,SET	1				0.02	0.044
007	04717-00800	WASHER,SEAL	1				0.001	0.0022
008	37150-24310	LEVER,SHIFT	1				0.145	0.319
009	04811-00150	O RING	1				0.001	0.0022
010	34150-24350	STOPPER,LEVER	1				0.015	0.033
011	01120-50816	BOLT	1				0	0
012	35320-24430	LEVER,AUX S-CHANGE	1				0.405	0.891
013	05411-00632	PIN,SPRING	1				0.004	0.0088
014	37300-24560	GRIP,LEVER	1				0.02	0.044

PTO GEAR SHIFT LEVER

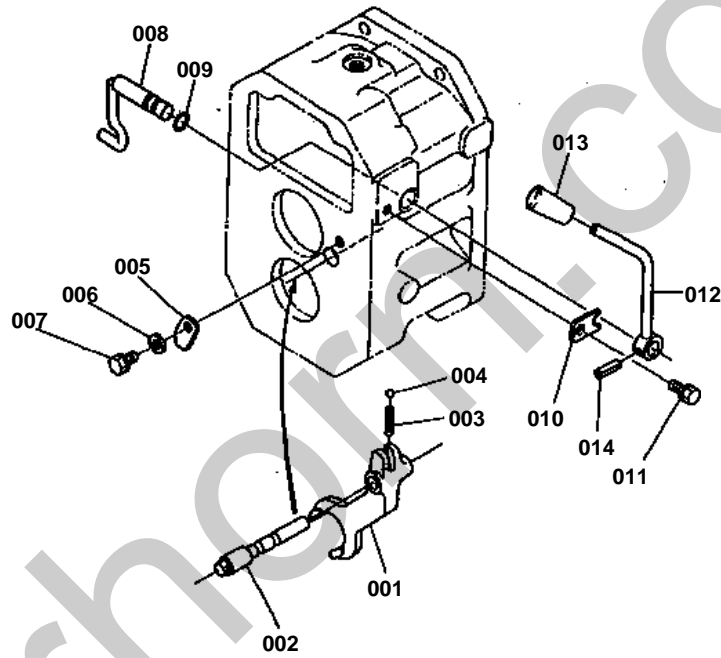

3570-24000
3570-24-01



PTO GEAR SHIFT LEVER

↔ Interchangeable; ≠ not interchangeable; ← new for old; → old for new

REF.No	Part No.	Description	Q'ty	S.No.	I/C	REMARKS	Weight (kgf)	Weight (lb)
001	35340-25610	FORK,SHIFT	1				0	0
002	35370-25620	SHAFT,FORK	1				0.11	0.242
003	62231-18530	SPRING,STOPPER	1				0.01	0.022
004	07715-01605	BALL	1				0.003	0.0066
005	35370-25560	RETAINER,SHAFT 1	1				0.012	0.0264
006	04013-50080	WASHER,PLAIN	1				0	0
007	01123-50820	BOLT	1				0.011	0.0242
008	35340-25630	LEVER,SHIFT	1				0.2	0.44
009	04811-00150	O RING	1				0.001	0.0022
010	35340-25640	RETAINER,SHAFT 2	1				0.02	0.044
011	01120-50816	BOLT	1				0	0
012	35320-25650	LEVER,SPEED CHANGE	1				0.3	0.66
013	37300-24560	GRIP,LEVER	1				0.02	0.044
014	05411-00635	PIN,SPRING	1				0.005	0.011

SHUTTLE LEVER

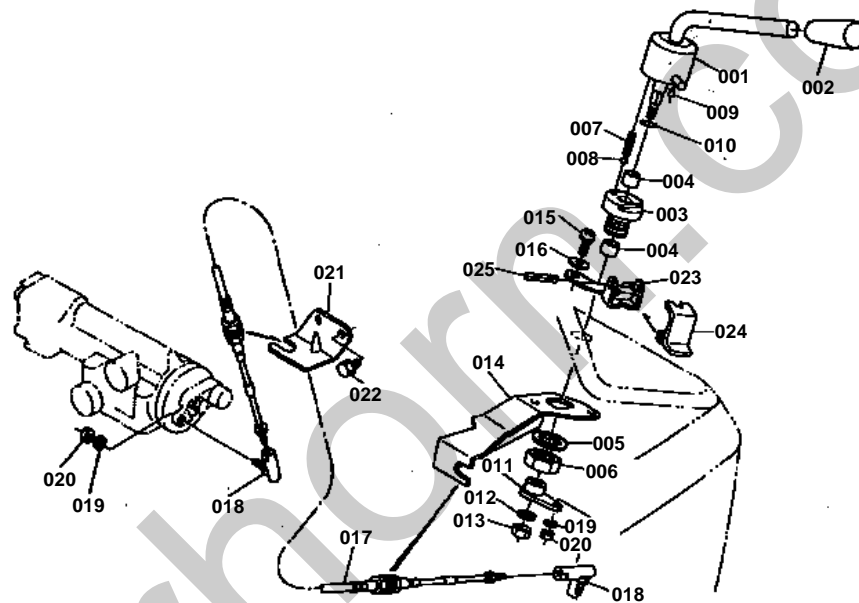



SHUTTLE LEVER

↔ Interchangeable; ≠ not interchangeable; ← new for old; → old for new

REF.No	Part No.	Description	Q'ty	S.No.	I/C	REMARKS	Weight (kgf)	Weight (lb)
001	35370-31210	LEVER,SHUTTLE	1				0.57	1.254
002	35370-31230	GRIP,LEVER	1				0.02	0.044
003	35370-31220	SUPPORT,LEVER SHAFT	1				0.145	0.319
004	41081-12120	BUSH	2				0	0
005	04512-50200	WASHER,SPRING	1				0	0
006	02172-50200	NUT	1				0.03	0.066
007	35370-31240	SPRING	1				0.005	0.011
008	07715-01603	BALL	1				0.001	0.0022
009	05012-00506	PIN,STRAIGHT	1				0.001	0.0022
010	04811-10120	O RING	1				0.001	0.0022
011	35370-31250	LEVER 1	1				0.045	0.099
012	04512-50080	WASHER,SPRING	1				0.001	0.0022
013	02114-50080	NUT	1				0.005	0.011
014	35370-31260	BRACKET	1				0.28	0.616
015	03004-50820	SCREW,WITH WASHER	2				0.011	0.0242
016	04012-50080	WASHER,PLAIN	2				0.001	0.0022
017	35370-31270	CABLE,PUSHPULL	1				0.265	0.583
018	35370-31280	END,ROD	2				0.025	0.055
019	04512-50050	WASHER,SPRING	2				0	0
020	02054-50050	NUT	2				0.002	0.0044
021	35370-31290	BRACKET 1	1				0.095	0.209
022	01123-50816	BOLT	2				0.011	0.0242
023	35370-31310	ASSY HDR,LOCK LEVER	1				0.07	0.154
024	35370-31340	LEVER,LOCK	1				0.075	0.165
025	05411-00536	PIN,SPRING	1				0.003	0.0066

DIFFERENTIAL SYSTEM

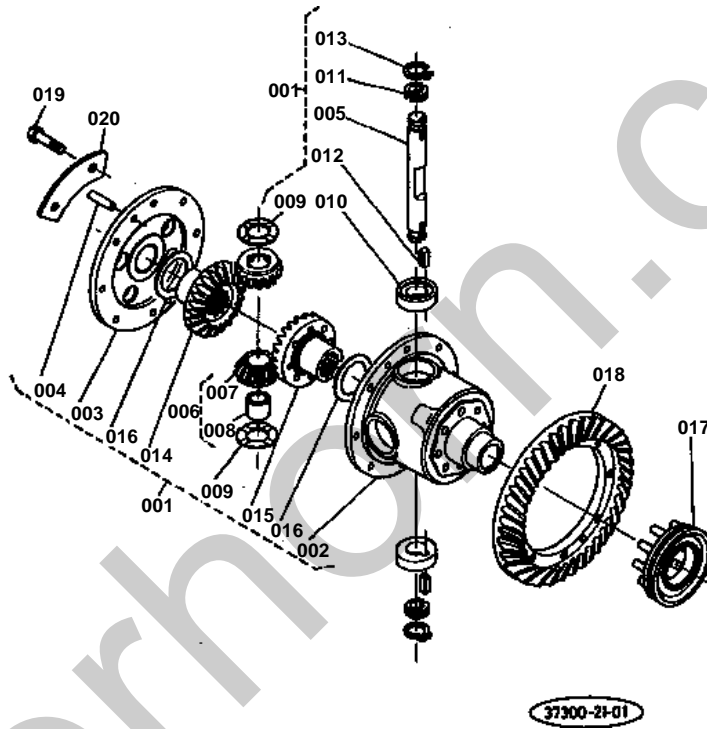



DIFFERENTIAL SYSTEM

↔ Interchangeable; ≠ not interchangeable; ← new for old; → old for new

REF.No	Part No.	Description	Q'ty	S.No.	I/C	REMARKS	Weight (kgf)	Weight (lb)
001	37300-26100	ASSY DIFFERENTIAL	1				7	15.4
002	37300-26510	CASE,DIFFERENTIAL	1				2.5	5.5
003	37300-26520	CAP,DIFF CASE	1				1.35	2.97
004	37300-26530	PIN,STRAIGHT	2				0.03	0.066
005	37300-26340	SHAFT,DIFF PINION	2				0.27	0.594
006	37300-26310	ASSY PINION,DIFF	4				0.17	0.374
007	99999-99999	BLANK	0			ORDER BY REF.No.006	0	0
008	31220-26360	BUSH	4				0.015	0.033
009	37300-26390	WASHER	4				0.02	0.044
010	37300-26370	BUSH	4				0.07	0.154
011	37300-26230	COLLAR,SET 4.9	8				0.005	0.011
011	37300-26240	COLLAR,SET 5.0	8				0.005	0.011
011	37300-26250	COLLAR,SET 5.1	8				0.005	0.011
012	37300-26280	KEY	4				0.005	0.011
013	04612-00260	CIR-CLIP,EXTERNAL	4				0.002	0.0044
014	35300-26430	GEAR,DIFF SIDE RH	1				0.47	1.034
015	35300-26440	GEAR,DIFF SIDE LH	1				0.63	1.386
016	37300-26480	WASHER	2				0.015	0.033
016	37300-26490	WASHER	2				0.015	0.033
017	37300-26610	SHIFTER,DIFF LOCK	1				0.46	1.012
018	99999-99999	BLANK	0			ORDER BY REF.No.021	0	0
019	37300-26260	BOLT	8				0.305	0.671
020	37300-26270	WASHER	4				0.015	0.033
021	35300-22100	ASSY GEAR,SPIRAL BEV	1			REF.No.001 ON L.No.0C09-L0	5.3	11.66

DIFF LOCK PEDAL

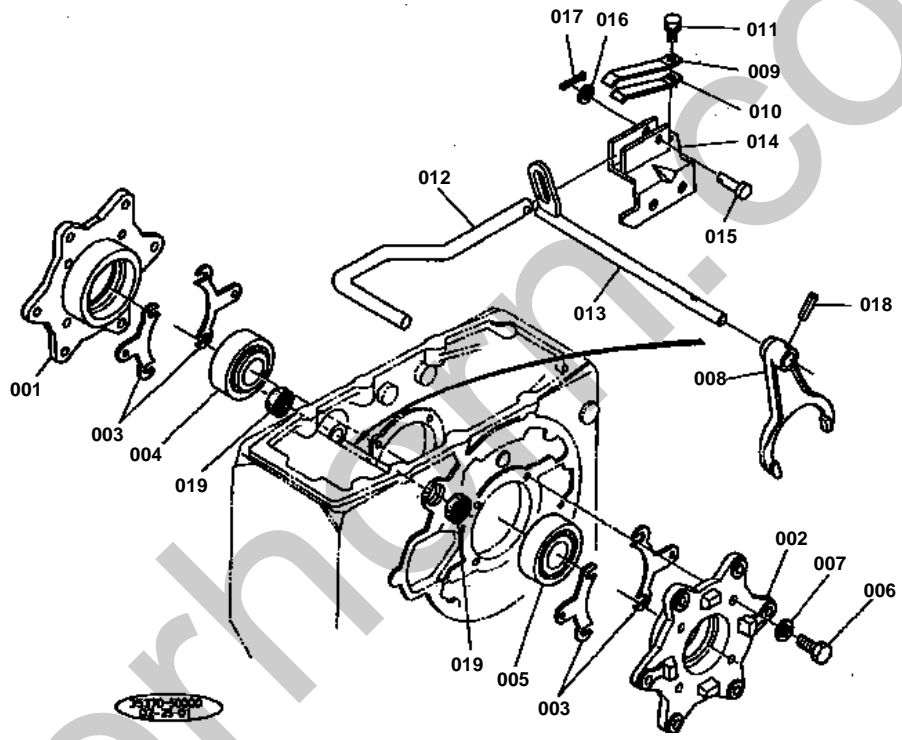



DIFF LOCK PEDAL

↔ Interchangeable; ≠ not interchangeable; ← new for old; → old for new

REF.No	Part No.	Description	Q'ty	S.No.	I/C	REMARKS	Weight (kgf)	Weight (lb)
001	37300-26550	CASE,DIFF BEARING RH	1				0	0
002	37300-26560	CASE,DIFF BEARING LH	1				0	0
003	37150-26160	SHIM 0.2	12				0.005	0.011
003	37150-26170	SHIM 0.1	8				0.005	0.011
003	37150-26180	SHIM 0.5	4				0.01	0.022
004	08711-32011	BEARING,TAPER ROLLER	1				0.538	1.1836
005	08711-30209	BEARING,TAPER ROLLER	1				0.458	1.0076
006	01173-51030	BOLT	8				0.023	0.0506
007	04512-50100	WASHER,SPRING	8				0	0
008	37300-26630	FORK,SHIFT	1				0.43	0.946
009	37150-26643	SPRING	1				0.033	0.0726
010	37150-26660	SPRING	1				0.025	0.055
011	01120-50816	BOLT	1				0	0
012	37300-26650	PEDAL,DIFF LOCK	1				0.635	1.397
013	37300-26680	CAM,DIFF LOCK	1				0.252	0.5544
014	37300-26670	BRACKET,PEDAL	1				0.655	1.441
015	05112-50835	PIN,JOINT	1				0.016	0.0352
016	04012-50080	WASHER,PLAIN	1				0.001	0.0022
017	05511-50218	PIN,SPLIT	1				0.001	0.0022
018	05411-00630	PIN,SPRING	1				0.004	0.0088
019	09500-16287	SEAL,OIL	2				0.01	0.022

DIFF YOKE SHAFT

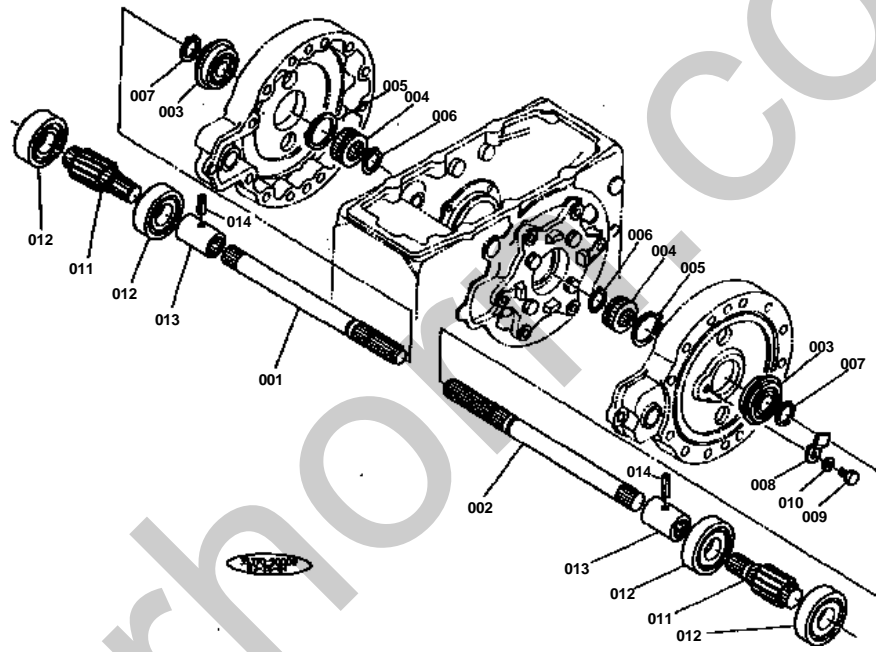



DIFF YOKE SHAFT

↔ Interchangeable; ≠ not interchangeable; ← new for old; → old for new

REF.No	Part No.	Description	Q'ty	S.No.	I/C	REMARKS	Weight (kgf)	Weight (lb)
001	37300-26710	SHAFT,DIFF GEAR RH	1				2.5	5.5
002	37300-26720	SHAFT,DIFF GEAR LH	1				2.6	5.72
003	08151-06007	BEARING,BALL	2				0.158	0.3476
004	37300-28190	BOSS,SPLINE	2				0.105	0.231
005	04612-00450	CIR-CLIP,EXTERNAL	2				0.007	0.0154
006	04612-00320	CIR-CLIP,EXTERNAL	2				0.004	0.0088
007	04612-00350	CIR-CLIP,EXTERNAL	2				0.01	0.022
008	34150-21942	RETAINER,BEARING	2				0.035	0.077
009	01153-50818	BOLT	2				0.01	0.022
010	04512-50080	WASHER,SPRING	2				0.001	0.0022
011	35370-26750	SHAFT,GEAR 10	2				1.12	2.464
012	08100-00026	BEARING,BALL	4				0.495	1.089
013	37300-28180	COUPLING	2				0.28	0.616
014	05411-00545	PIN,SPRING	2				0.004	0.0088

REAR AXLE

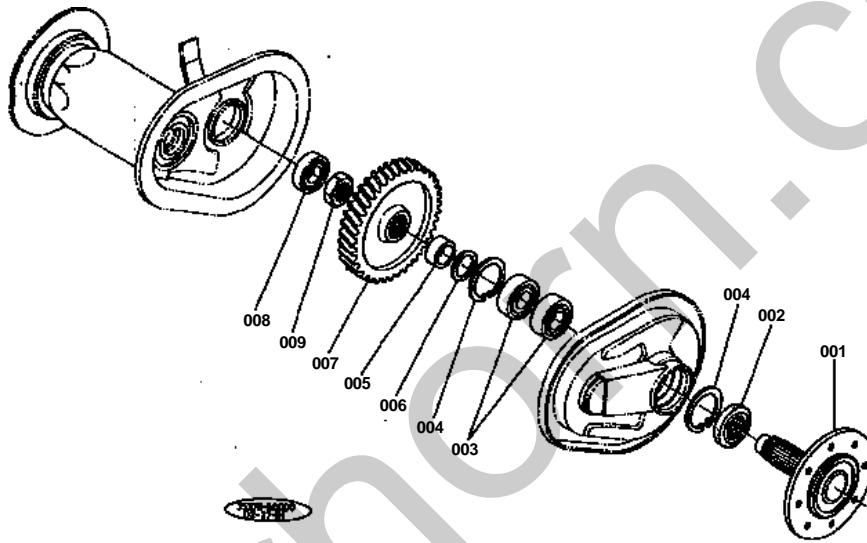



REAR AXLE

↔ Interchangeable; ≠ not interchangeable; ← new for old; → old for new

REF.No	Part No.	Description	Q'ty	S.No.	I/C	REMARKS	Weight (kgf)	Weight (lb)
001	35340-27110	AXLE,REAR	2				12	26.4
002	37300-27560	SEAL,OIL	2				0.172	0.3784
003	08101-06211	BEARING,BALL	4				0.6	1.32
004	04611-01000	CIR-CLIP,INTERNAL	4				0.042	0.0924
005	35340-27140	COLLAR	2				0.055	0.121
006	34350-27150	WASHER	2				0.015	0.033
007	35370-26830	GEAR,SPUR 66	2				9.3	20.46
008	08100-00028	BEARING,BALL	2				0.67	1.474
009	37300-27280	NUT 50	2				0.135	0.297

AXLE CASE

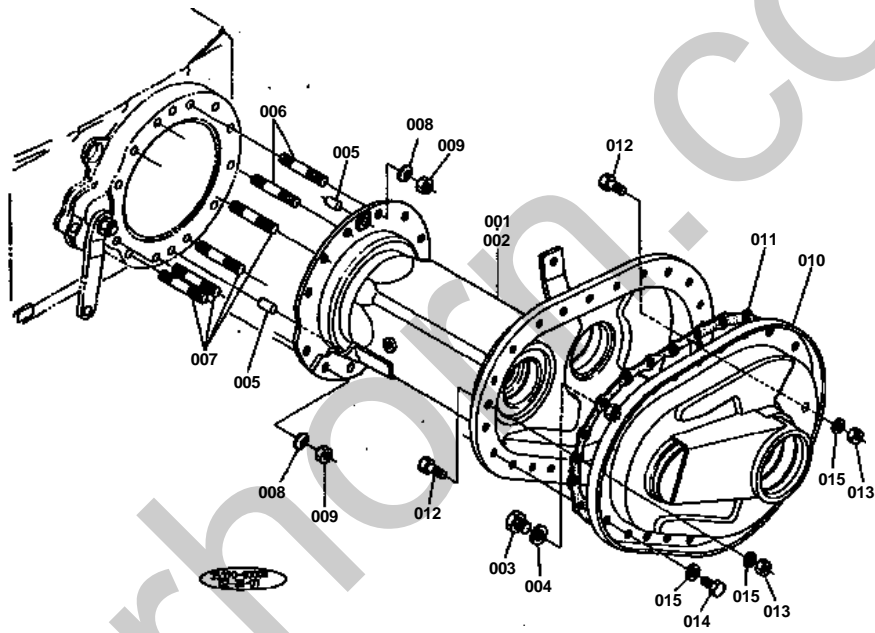

**AXLE CASE**

↔ Interchangeable; ≠ not interchangeable; ← new for old; → old for new

REF.No	Part No.	Description	Q'ty	S.No.	I/C	REMARKS	Weight (kgf)	Weight (lb)
001	35370-27310	CASE,AXLE RH	1				22.4	49.28
002	35370-27320	CASE,AXLE LH	1				22.2	48.84
003	06331-35016	PLUG	2				0.04	0.088
004	04717-01600	WASHER,SEAL	2				0.003	0.0066
005	05012-01325	PIN,STRAIGHT	4				0.028	0.0616
006	35340-27350	STUD	4				0.072	0.1584
007	35340-27380	STUD	20				0.08	0.176
008	35340-27370	SPRING,PLATE	24				0.015	0.033
009	35340-27360	NUT	24				0.015	0.033
010	35340-27330	COVER,AXLE CASE	2				9.3	20.46
011	37300-27340	PACKING	2				0.012	0.0264
012	37150-27390	BOLT,REAMER	4				0.02	0.044
013	02176-50100	NUT	4				0.005	0.011
014	01176-51022	BOLT	44				0.019	0.0418
015	04512-50100	WASHER,SPRING	48				0	0

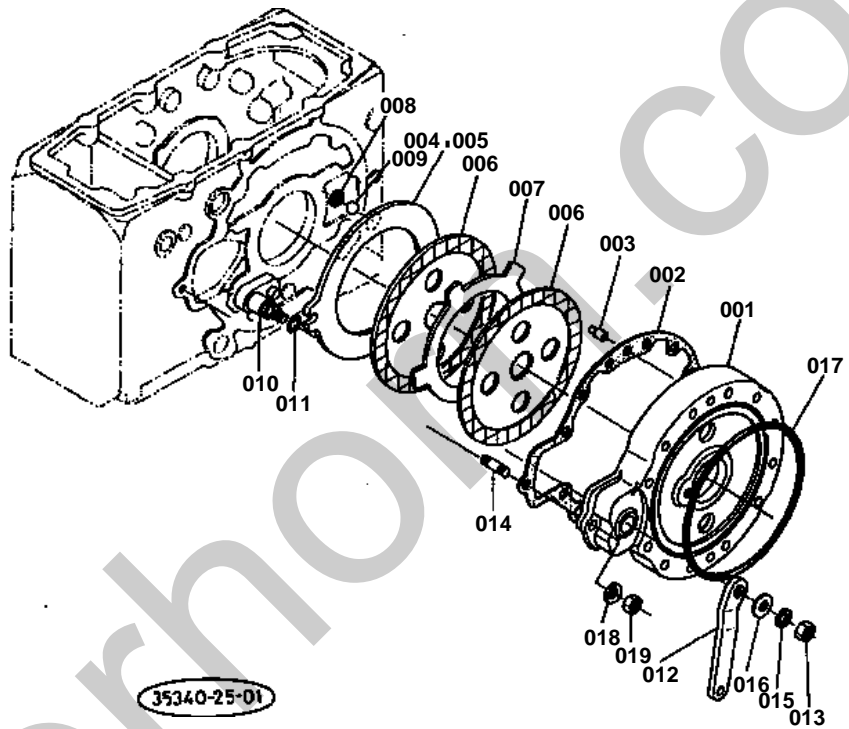

**BRAKE**

↔ Interchangeable; ≠ not interchangeable; ← new for old; → old for new

REF.No	Part No.	Description	Q'ty	S.No.	I/C	REMARKS	Weight (kgf)	Weight (lb)
001	37300-28156	CASE,BRAKE	2				0	0
002	37260-28160	PACKING	2				0	0
003	37300-28170	PIN,STRAIGHT	4				0.025	0.055
004	37150-28240	PLATE,CAM LH	1				1.13	2.486
005	37150-28270	PLATE,CAM RH	1				1.08	2.376
006	37150-28200	DISK,BRAKE	4				0.774	1.7028
007	37720-28170	PLATE	2				0.422	0.9284
008	37150-28250	SEAT,BALL	12				0.003	0.0066
009	07715-00805	BALL	12				0.016	0.0352
010	37720-28216	CAM,BRAKE	2				0.34	0.748
011	04811-00180	O RING	2				0.001	0.0022
012	37720-28220	LEVER,CAM	2				0.28	0.616
013	02176-50120	NUT	2				0.01	0.022
014	35340-14180	STUD	2				0	0
015	04512-50120	WASHER,SPRING	2				0	0
016	04013-50120	WASHER,PLAIN	2				0	0
017	37300-27440	O RING	2				0.01	0.022
018	35340-27370	SPRING,PLATE	2				0.015	0.033
019	35340-27360	NUT	2				0.015	0.033

BRAKE PEDAL

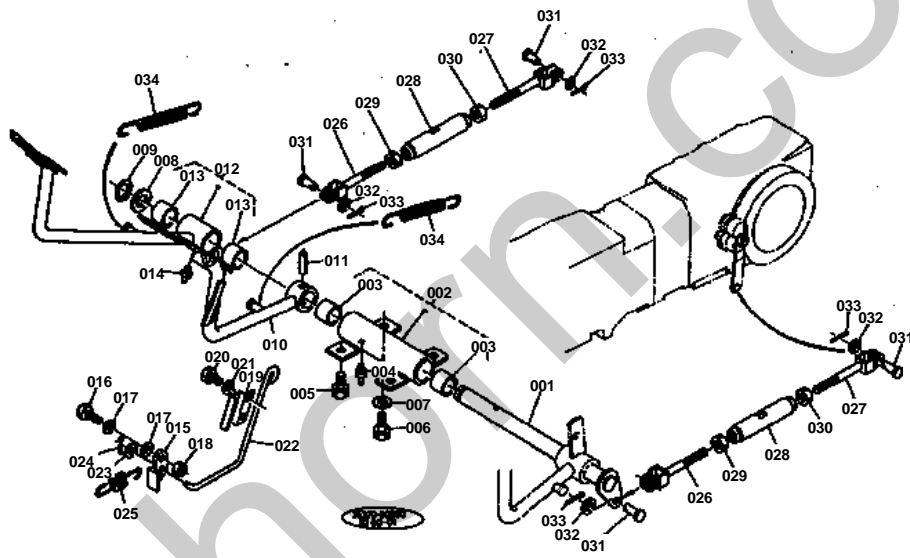

**BRAKE PEDAL**

↔ Interchangeable; ≠ not interchangeable; ← new for old; → old for new

REF.No	Part No.	Description	Q'ty	S.No.	I/C	REMARKS	Weight (kgf)	Weight (lb)
001	37150-28410	SHAFT,BRAKE PEDAL	1				1.43	3.146
002	37150-28420	SUPPORT,PEDAL SHAFT	1				0.95	2.09
003	34150-28430	BUSH	2				0.04	0.088
004	06613-10675	NIPPLE,GREASE	1				0.003	0.0066
005	01133-51020	BOLT	2				0.02	0.044
006	01133-51025	BOLT	2				0.023	0.0506
007	04013-50100	WASHER,PLAIN	2				0	0
008	32150-28460	COLLAR	1				0.007	0.0154
009	04612-00250	CIR-CLIP,EXTERNAL	1				0.002	0.0044
010	35300-28610	PEDAL,BRAKE LH	1				1.5	3.3
011	05411-00840	PIN,SPRING	1				0.008	0.0176
012	35300-28620	PEDAL,BRAKE RH	1				1.53	3.366
013	34150-28430	BUSH	2				0.04	0.088
014	06613-10675	NIPPLE,GREASE	1				0.003	0.0066
015	34150-28810	RATCHET	1				0.045	0.099
016	34150-28820	BOLT	1				0.04	0.088
017	04011-50120	WASHER,PLAIN	2				0.005	0.011
018	02174-50120	NUT	1				0.01	0.022
019	34150-28880	GUIDE,RATCHET	1				0.04	0.088
020	01150-50812	BOLT	2				0.009	0.0198
021	04512-50080	WASHER,SPRING	2				0.001	0.0022
022	34150-28870	ROD,RATCHET	1				0.09	0.198
023	04012-50060	WASHER,PLAIN	1				0.001	0.0022
024	05511-50215	PIN,SPLIT	1				0.001	0.0022
025	37150-28850	SPRING	1				0.005	0.011
026	35340-28930	ROD,BRAKE 1	2				0.19	0.418
027	35340-28940	ROD,BRAKE 2	2				0.19	0.418
028	38240-28980	TURNBUCKLE	2				0.29	0.638
029	37300-28990	NUT	2				0.015	0.033
030	02174-50140	NUT	2				0.014	0.0308
031	05122-50828	PIN,JOINT	4				0.012	0.0264
032	04012-50080	WASHER,PLAIN	4				0.001	0.0022
033	05511-50215	PIN,SPLIT	4				0.001	0.0022
034	37150-15840	SPRING	2				0.06	0.132

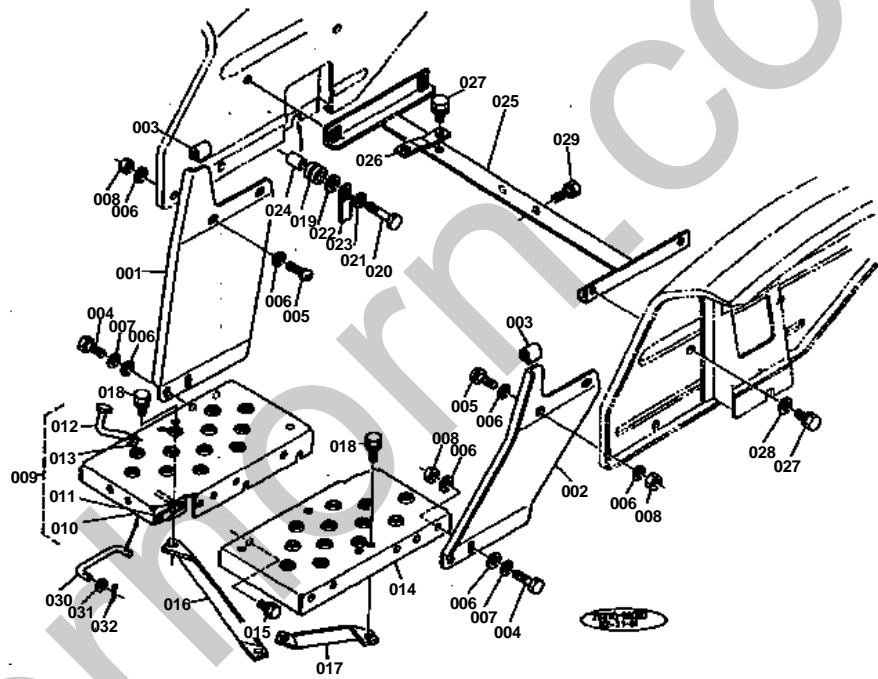



STEP

↔ Interchangeable; ≠ not interchangeable; ← new for old; → old for new

REF.No	Part No.	Description	Q'ty	S.No.	I/C	REMARKS	Weight (kgf)	Weight (lb)
001	35370-29310	STAY,FENDER RH	1				1.12	2.464
002	35370-29320	STAY,FENDER LH	1				1.11	2.442
003	37150-13920	CUSHION	2				0.005	0.011
004	01150-50820	BOLT	4				0.011	0.0242
005	03004-50820	SCREW,WITH WASHER	4				0.011	0.0242
006	04015-50080	WASHER,PLAIN	16				0	0
007	04512-50080	WASHER,SPRING	4				0.001	0.0022
008	02114-50080	NUT	8				0.005	0.011
009	35260-29902	COMP,STEP RH	1				3.2	7.04
010	99999-99999	BLANK	0			ORDER BY REF.No.009	0	0
011	99999-99999	BLANK	0			ORDER BY REF.No.009	0	0
012	99999-99999	BLANK	0			ORDER BY REF.No.009	0	0
013	99999-99999	BLANK	0			ORDER BY REF.No.009	0	0
014	35370-29920	STEP LH	1				2.7	5.94
015	01133-51016	BOLT	6				0.015	0.033
016	35260-29930	SUPPORT,STEP RH	1				0.26	0.572
017	35260-29940	SUPPORT,STEP LH	1				0.255	0.561
018	01123-50816	BOLT	2				0.011	0.0242
019	35260-29950	CUSHION	2				0.02	0.044
020	01173-51050	BOLT	2				0.035	0.077
021	04512-50100	WASHER,SPRING	2				0	0
022	04013-50100	WASHER,PLAIN	2				0	0
023	34150-29370	CLAMP,CORD	2				0.005	0.011
024	66591-41550	COLLAR	2				0.02	0.044
025	35370-29020	LINK,FENDER SUPPORT	1				3	6.6
026	35370-29030	STAY,LEVER SIDE	1				0.035	0.077
027	01133-51020	BOLT	4				0.02	0.044
028	04015-50100	WASHER,PLAIN	4				0.016	0.0352
029	01133-51025	BOLT	2				0.023	0.0506
030	37150-17580	ROD,ACCELERATOR	1				0.025	0.055
031	04012-50060	WASHER,PLAIN	2				0.001	0.0022
032	05511-50212	PIN,SPLIT	2				0.001	0.0022

PANEL

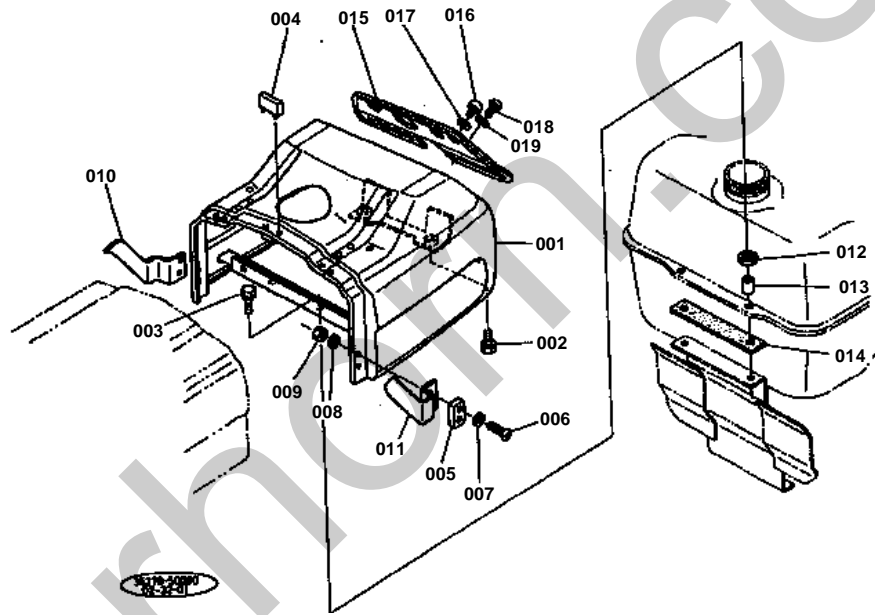



PANEL

↔ Interchangeable; ≠ not interchangeable; ← new for old; → old for new

REF.No	Part No.	Description	Q'ty	S.No.	I/C	REMARKS	Weight (kgf)	Weight (lb)
001	35370-31110	PANEL	1				8	17.6
002	01120-50816	BOLT	2				0	0
003	01120-50830	BOLT	2				0	0
004	33251-83490	CUSHION 1	3				0.008	0.0176
005	37150-18180	CUSHION	2				0.015	0.033
006	03054-50514	SCREW,PAN HEAD	4				0.004	0.0088
007	04013-50050	WASHER,PLAIN	4				0	0
008	04512-50050	WASHER,SPRING	4				0	0
009	02054-50050	NUT	4				0.002	0.0044
010	37150-31180	GUIDE RH	1				0.07	0.154
011	37150-31190	GUIDE LH	1				0.065	0.143
012	37300-35120	GUSHION	2				0.003	0.0066
013	37300-35150	SPACER	2				0.005	0.011
014	37300-35160	CUSHION	1				0.025	0.055
015	35370-31120	DASHBOARD	1				0.515	1.133
016	34150-31140	SCREW,BINDING HEAD	4				0.009	0.0198
017	04013-50080	WASHER,PLAIN	4				0	0
018	03024-50510	SCREW,WITH WASHER	1				0.002	0.0044
019	04012-50050	WASHER,PLAIN	1				0.001	0.0022

HOUR METER AND SWITCH

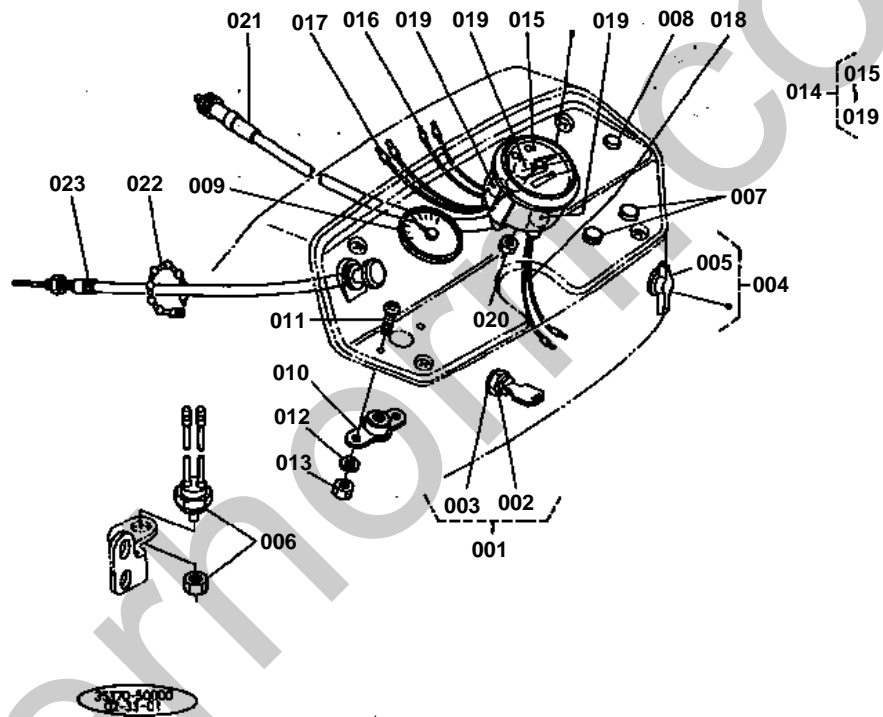



HOUR METER AND SWITCH

↔ Interchangeable; ≠ not interchangeable; ← new for old; → old for new

REF.No	Part No.	Description	Q'ty	S.No.	I/C	REMARKS	Weight (kgf)	Weight (lb)
001	37150-31820	SWITCH,MAIN	1				0.19	0.418
002	37150-31910	NUT,RING	1				0.3	0.66
003	37150-31920	PACKING	1				0.001	0.0022
004	37150-32200	SWITCH,STARTER	1				0.275	0.605
005	37150-32210	ASSY KNOB	1				0.02	0.044
006	37150-32240	SWITCH,SAFETY	1				0.12	0.264
007	35110-32420	PLUG	2				0.002	0.0044
008	34159-32610	CAP,RUBBER	1				0	0
009	34260-31300	HEAT INDICATER	1				0.144	0.3168
010	15401-65950	LAMP,GLOW	1				0.053	0.1166
011	03054-50510	SCREW,PAN HEAD	2				0.003	0.0066
012	04512-50050	WASHER,SPRING	4				0	0
013	02054-50050	NUT	4				0.002	0.0044
014	35370-34600	METER,TRACTOR	1				0.41	0.902
015	35370-34630	PLATE,DIAL	1				0	0
016	35370-34610	ASSY CORD	1				0.02	0.044
017	35370-34620	ASSY CORD	1				0.02	0.044
018	35370-34640	ASSY CORD	1				0.02	0.044
019	35370-34650	LAMP	3				0.005	0.011
020	02054-50050	NUT	1				0.002	0.0044
021	35340-34650	CABLE,TRACTOR METER	1				0.25	0.55
022	34350-29380	BAND,CORD	1				0.001	0.0022
023	35340-34700	WIRE,DECOMP	1				0.114	0.2508

REGULATOR

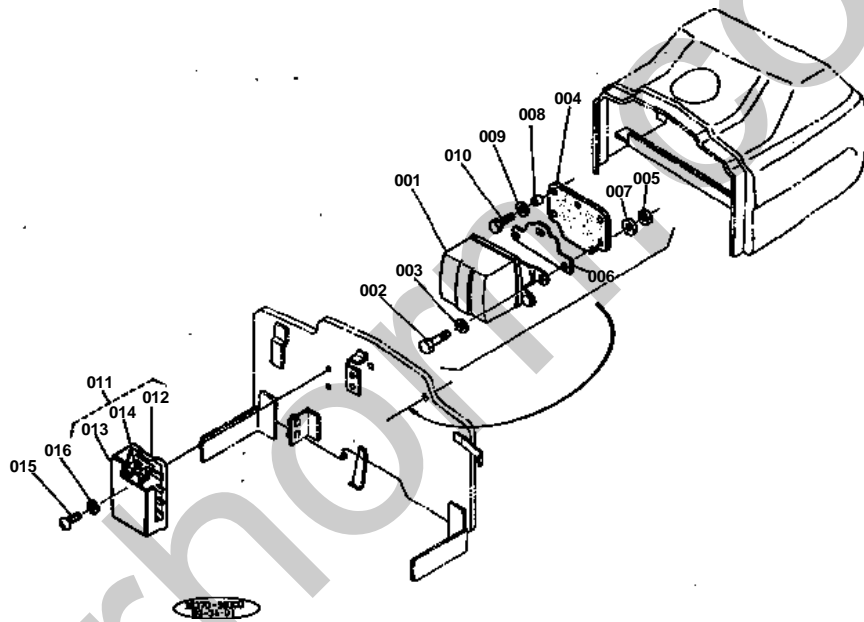



REGULATOR

↔ Interchangeable; ≠ not interchangeable; ← new for old; → old for new

REF.No	Part No.	Description	Q'ty	S.No.	I/C	REMARKS	Weight (kgf)	Weight (lb)
001	33251-74010	ASSY REGULATOR	1				0.35	0.77
002	37300-33460	BOLT	3				0.005	0.011
003	04012-50060	WASHER,PLAIN	3				0.001	0.0022
004	37300-33430	CUSHION	1				0.1	0.22
005	02014-50060	NUT	3				0.003	0.0066
006	37300-33420	COVER,REGULATOR	1				0.07	0.154
007	37300-33440	CUSHION	3				0.001	0.0022
008	37300-33450	COLLAR	2				0.005	0.011
009	04015-50060	WASHER,PLAIN	2				0	0
010	01202-50622	BOLT	2				0.007	0.0154
011	34260-33600	ASSY CASE,FUSE	1				0.042	0.0924
012	34260-33610	CASE,FUSE	1				0.042	0.0924
013	34260-33620	COVER,FUSE CASE	1				0.01	0.022
014	34260-33630	FUSE	6				0.001	0.0022
015	03054-50520	SCREW,PAN HEAD	2				0.005	0.011
016	04512-50050	WASHER,SPRING	4				0	0

BATTERY

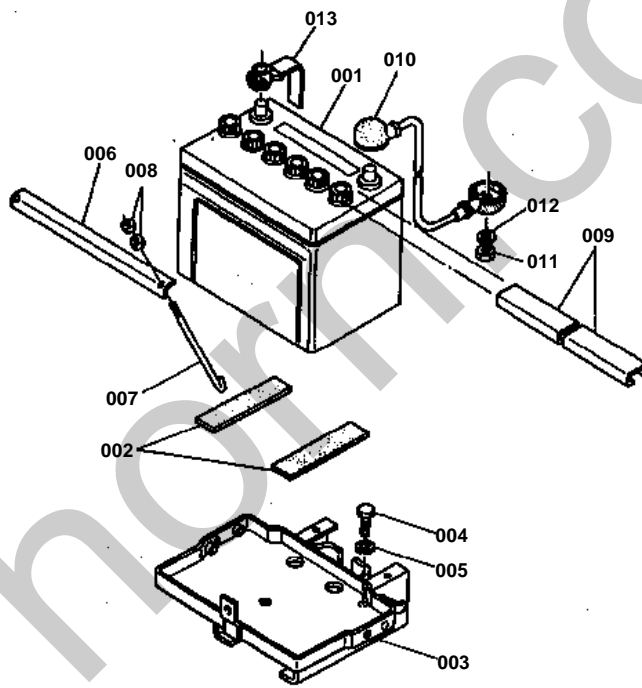

**BATTERY**

↔ Interchangeable; ≠ not interchangeable; ← new for old; → old for new

REF.No	Part No.	Description	Q'ty	S.No.	I/C	REMARKS	Weight (kgf)	Weight (lb)
001	32360-33200	BATTERY,DRY	1				18	39.6
002	32350-33233	CUSHION	2				0	0
003	35340-33210	SUPPORT,BATTERY	1				5.4	11.88
004	01170-51020	BOLT	4				0	0
005	04512-50100	WASHER,SPRING	4				0	0
006	32350-33270	RETAINER,BATTERY	1				0.35	0.77
007	34260-33290	BOLT,HOOK	2				0.08	0.176
008	02112-50080	NUT	4				0.003	0.0066
009	34260-33390	COVER,BATTERY	1				0.053	0.1166
010	34260-33330	CORD,BATTERY	1				0.25	0.55
011	02114-50080	NUT	1				0.005	0.011
012	04512-50080	WASHER,SPRING	1				0.001	0.0022
013	34200-33380	CORD,EARTH	1				0.19	0.418

HEAD LAMP

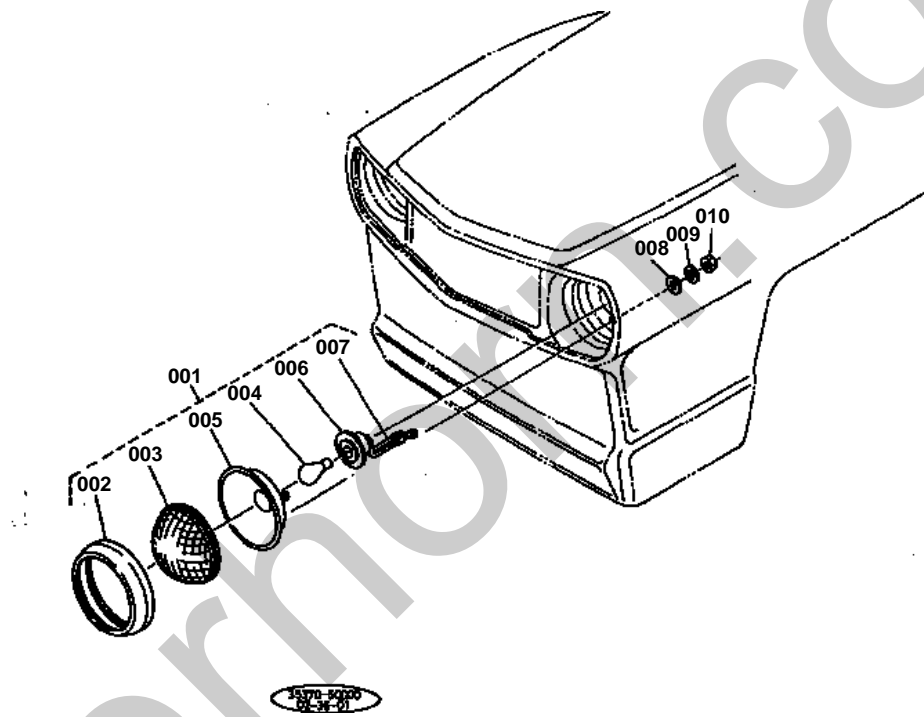



HEAD LAMP

↔ Interchangeable; ≠ not interchangeable; ← new for old; → old for new

REF.No	Part No.	Description	Q'ty	S.No.	I/C	REMARKS	Weight (kgf)	Weight (lb)
001	32240-33800	ASSY LAMP,HEAD	2				0.33	0.726
002	32240-33810	BODY	2				0.06	0.132
003	32280-33830	LENS,LAMP	2				0.098	0.2156
004	32150-33840	LAMP	2				0.014	0.0308
005	32240-33870	REFLECTOR,LAMP	2				0.135	0.297
006	32280-33850	CUSHION	2				0.005	0.011
007	32240-33880	COMP,CORD	2				0.028	0.0616
008	04013-50050	WASHER,PLAIN	6				0	0
009	04512-50050	WASHER,SPRING	6				0	0
010	02054-50050	NUT	6				0.002	0.0044

WIRING DIAGRAM

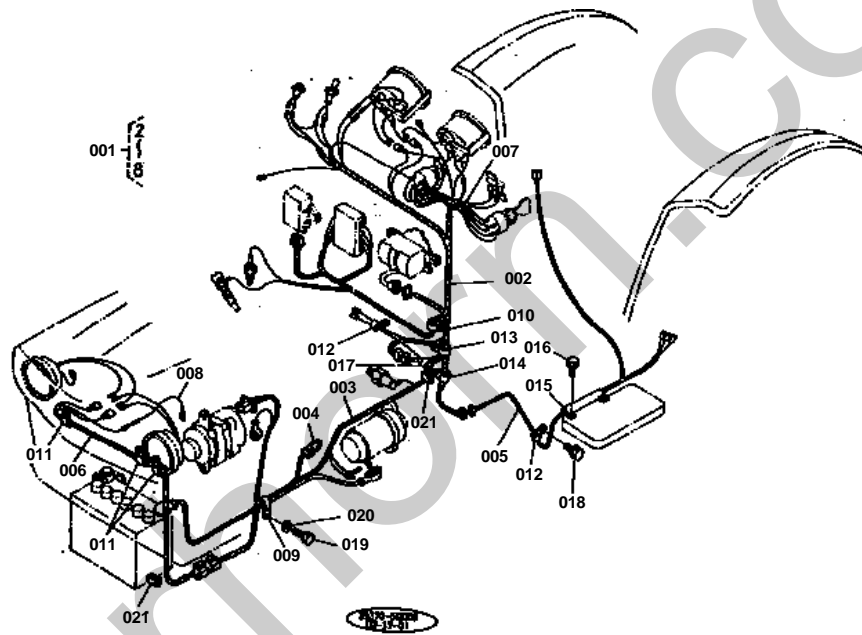



WIRING DIAGRAM

↔ Interchangeable; ≠ not interchangeable; ← new for old; → old for new

REF.No	Part No.	Description	Q'ty	S.No.	I/C	REMARKS	Weight (kgf)	Weight (lb)
001	35370-34300	ASSY WIRE HARNESS	1				0.99	2.178
002	35370-34310	WIRE HARNESS 1	1				0.6	1.32
003	35370-34320	WIRE HARNESS 2	1				0.2	0.44
004	67111-55190	LINK,FUSIBLE	1				0.005	0.011
005	35370-34330	WIRE HARNESS 3	1				0.13	0.286
006	35300-34340	WIRE HARNESS 4	1				0.05	0.11
007	35370-34350	WIRE HARNESS 5	1				0.025	0.055
008	35110-34350	CORD,EARTH	1				0.005	0.011
009	35340-29380	CLAMP,CORD	1				0.01	0.022
010	34150-29390	CLAMP,CORD	3				0.004	0.0088
011	34150-34480	CLAMP,CORD	3				0.002	0.0044
012	32240-34490	CLAMP,CORD	5				0.003	0.0066
013	57351-72320	CLAMP,CORD	1				0.004	0.0088
014	32240-34460	CLAMP,CORD	3				0.011	0.0242
015	37150-34480	CLAMP,CORD	1				0.06	0.132
016	01123-50814	BOLT	2				0	0
017	66706-55220	CLAMP,CORD	4				0.002	0.0044
018	01120-50814	BOLT	1				0	0
019	01173-51218	BOLT	1				0.028	0.0616
020	04512-50120	WASHER,SPRING	1				0	0
021	37150-13920	CUSHION	2				0.005	0.011

FUEL FILTER

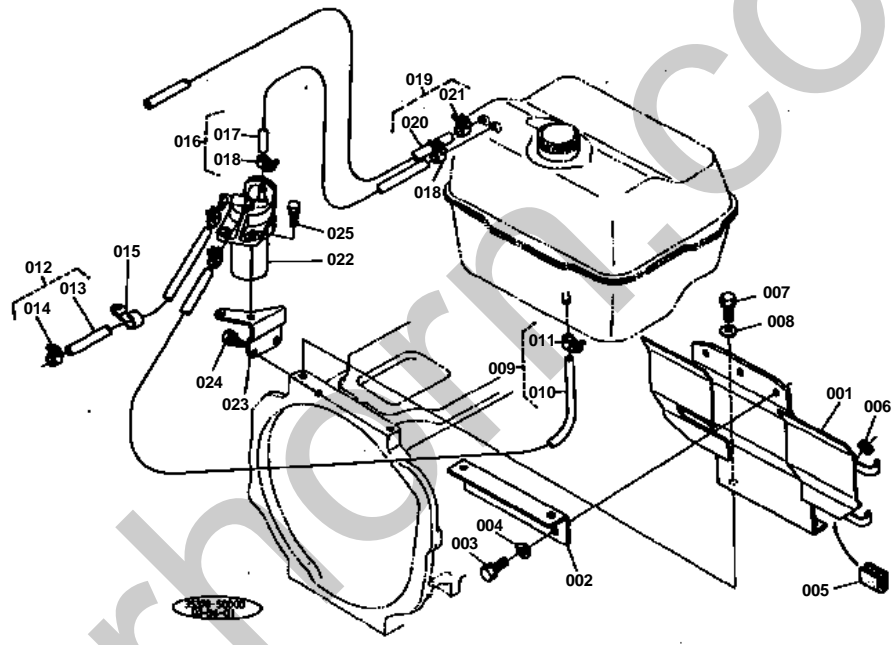



FUEL FILTER

↔ Interchangeable; ≠ not interchangeable; ← new for old; → old for new

REF.No	Part No.	Description	Q'ty	S.No.	I/C	REMARKS	Weight (kgf)	Weight (lb)
001	35370-35270	SUPPORT,FUEL TANK	1				2.025	4.455
002	37300-35260	BRACKET	1				0.196	0.4312
003	01130-51020	BOLT	3				0	0
004	04015-50100	WASHER,PLAIN	3				0.016	0.0352
005	37150-13920	CUSHION	1				0.005	0.011
006	32150-29180	CAP	1				0.002	0.0044
007	01120-50818	BOLT	2				0	0
008	04015-50080	WASHER,PLAIN	2				0	0
009	15471-54060	ASSY PIPE,FUEL 1	1				0.05	0.11
010	99999-99999	BLANK	0			ORDER BY REF.No.009	0	0
011	14301-42750	CLIP,PIPE	2				0.005	0.011
012	35340-35520	ASSY PIPE,FUEL 2	1				0.087	0.1914
013	99999-99999	BLANK	0			ORDER BY REF.No.013	0	0
014	14301-42753	CLIP,PIPE	2				0	0
015	34150-29390	CLAMP,CORD	1				0.004	0.0088
016	35340-35550	ASSY PIPE,FUEL 3	1				0.027	0.0594
017	99999-99999	BLANK	0			ORDER BY REF.No.017	0	0
018	10244-42320	CLIP,PIPE	2				0.001	0.0022
019	38240-35580	ASSY PIPE,FUEL 4	1				0.035	0.077
020	99999-99999	BLANK	0			ORDER BY REF.No.020	0	0
021	15271-42710	CLIP,PIPE	2				0	0
022	15575-43010	ASSY FILTER,FUEL	1				0	0
023	35260-35810	BRACKET,FILTER	1				0.12	0.264
024	01120-50816	BOLT	2				0	0
025	01120-50825	BOLT	2				0	0

FUEL FILTER SECTION PARTS

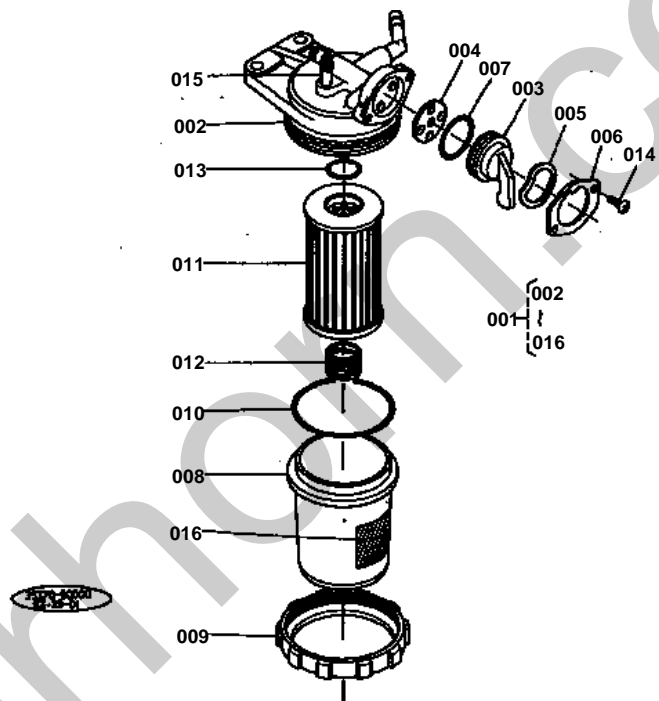



FUEL FILTER SECTION PARTS

↔ Interchangeable; ≠ not interchangeable; ← new for old; → old for new

REF.No	Part No.	Description	Q'ty	S.No.	I/C	REMARKS	Weight (kgf)	Weight (lb)
001	15575-43010	ASSY FILTER,FUEL	1				0	0
002	15575-43110	ASSY BODY	1				0.18	0.396
003	15521-43522	HANDLE,FILTER	1				0.04	0.088
004	15521-43672	GASKET	1				0.001	0.0022
005	15521-43542	PLATE,THRUST	1				0.001	0.0022
006	15521-43552	RETAINER,HANDLE	1				0.01	0.022
007	04811-10290	O RING	1				0.001	0.0022
008	15521-43130	POT,FILTER	1				0.1	0.22
009	15521-43150	RING,RETAINER	1				0.14	0.308
010	04811-50650	O RING	1				0.002	0.0044
011	15521-43160	ELEMENT,FILTER	1				0.07	0.154
012	15521-43930	SPRING	1				0.004	0.0088
013	04811-00160	O RING	1				0.001	0.0022
014	15521-93310	SCREW	2				0.004	0.0088
015	15521-43280	JOINT	1				0.009	0.0198
016	19271-87210	LABEL	1				0.001	0.0022

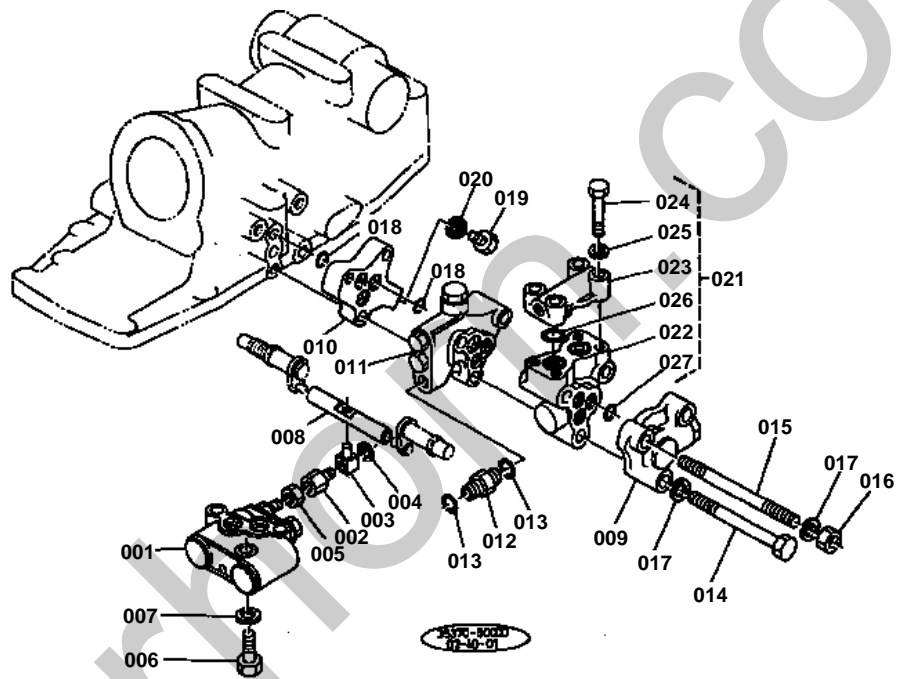



OIL HYDRAULIC SYSTEM

↔ Interchangeable; ≠ not interchangeable; ← new for old; → old for new

REF.No	Part No.	Description	Q'ty	S.No.	I/C	REMARKS	Weight (kgf)	Weight (lb)
001	37150-36400	VALVE,CONTROL	1				1.675	3.685
002	37150-36410	END,SPOOL 1	1				0.001	0.0022
003	37150-36420	END,SPOOL 2	1				0.02	0.044
004	04613-00060	CIR-CLIP,EXTERNAL	1				0	0
005	02112-50080	NUT	1				0.003	0.0066
006	01153-50850	BOLT	3				0.02	0.044
007	04512-50080	WASHER,SPRING	3				0.001	0.0022
008	37150-36430	LEVER,SPOOL DRIVE	1				0.09	0.198
009	37300-36600	ASSY VALVE,RELIEF	1				0.885	1.947
010	37150-36610	SPACER,VALVE	1				0.14	0.308
011	35370-16710	VALVE,FLOW PRIORITY	1				2.1	4.62
012	35270-16790	PIPE,JOINT	1				0.05	0.11
013	04810-00140	O RING	2				0.001	0.0022
014	35270-36810	BOLT	2				0.059	0.1298
015	35270-36820	STUD	1				0.65	1.43
016	02156-50080	NUT	1				0.004	0.0088
017	04512-50080	WASHER,SPRING	3				0.001	0.0022
018	04810-00140	O RING	6				0.001	0.0022
019	06331-35010	PLUG	1				0.012	0.0264
020	04717-01000	WASHER,SEAL	1				0.001	0.0022
021	35300-36700	ASSY BLOCK,O/P	1				2	4.4
022	35300-36710	BLOCK,O/P	1				1.6	3.52
023	35300-36720	COVER,O/P BLOCK	1				0.385	0.847
024	01153-50840	BOLT	4				0.018	0.0396
025	04512-50080	WASHER,SPRING	4				0.001	0.0022
026	04810-00200	O RING	2				0.001	0.0022
027	04810-00120	O RING	3				0.001	0.0022

CONTROL VALVE SECTION PARTS

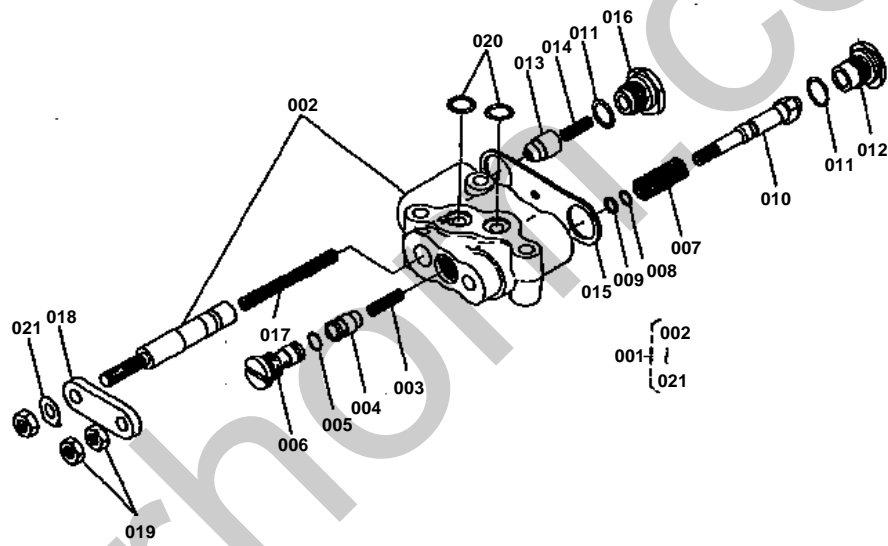



CONTROL VALVE SECTION PARTS

↔ Interchangeable; ≠ not interchangeable; ← new for old; → old for new

REF.No	Part No.	Description	Q'ty	S.No.	I/C	REMARKS	Weight (kgf)	Weight (lb)
001	37150-36400	ASSY CONTROL VALVE	1				1.675	3.685
002	99999-99999	BLANK	0			ORDER BY REF.No.001	0	0
003	37150-36580	SPRING	1				0.005	0.011
004	37150-36590	VALVE,CHECK	1				0.015	0.033
005	04811-00090	O RING	1				0.001	0.0022
006	37150-36440	SEAT	1				0.035	0.077
007	37150-36450	SPRING	1				0.005	0.011
008	04811-00070	O RING	1				0.001	0.0022
009	37150-36630	RING,BACK UP	1				0.001	0.0022
010	37150-36460	POPPET	1				0.005	0.011
011	04811-00150	O RING	2				0.001	0.0022
012	37150-36470	PLUG,SEAT	1				0.04	0.088
013	37150-36480	VALVE,UNLOADER	1				0.02	0.044
014	37150-36490	SPRING	1				0.005	0.011
015	37150-36510	PLATE	1				0.035	0.077
016	37150-36520	PLUG	1				0.043	0.0946
017	37150-36530	SPRING,RETURN	1				0.01	0.022
018	37150-36540	PLATE	1				0.145	0.319
019	37150-36550	NUT	3				0.005	0.011
020	04811-00120	O RING	2				0.001	0.0022
021	37150-36560	PLATE,LOCK	1				0.01	0.022

RELIEF VALVE SECTION PARTS

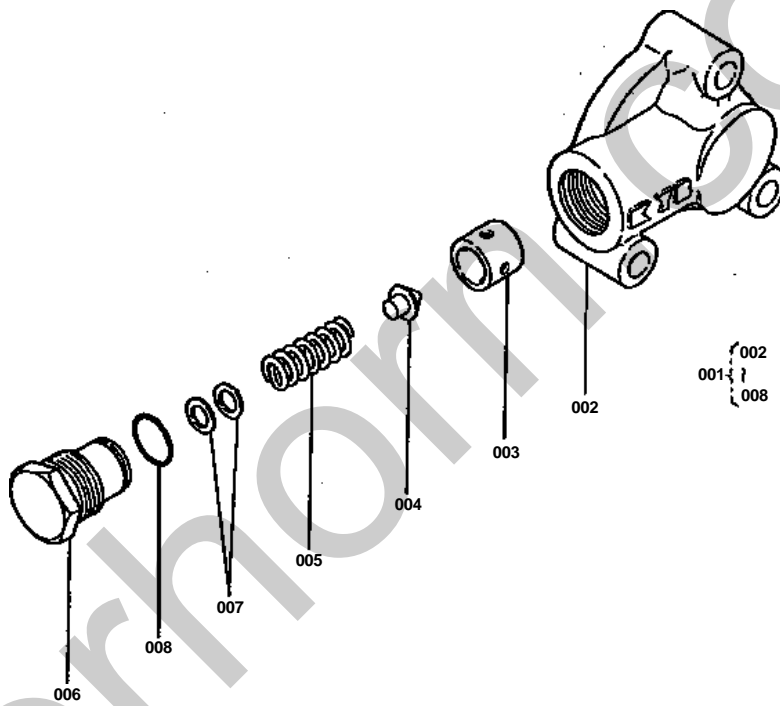



RELIEF VALVE SECTION PARTS

↔ Interchangeable; ≠ not interchangeable; ← new for old; → old for new

REF.No	Part No.	Description	Q'ty	S.No.	I/C	REMARKS	Weight (kgf)	Weight (lb)
001	37300-36600	ASSY VALVE,RELIEF	1				0.885	1.947
002	99999-99999	BLANK	0			ORDER BY REF.No.001	0	0
003	34220-36740	SEAT	1				0.016	0.0352
004	34220-36750	POPPET	1				0.002	0.0044
005	34220-36760	SPRING	1				0.01	0.022
006	34220-36770	PLUG	1				0.05	0.11
007	34220-36780	SHIM	1				0.001	0.0022
008	04811-10160	O RING	1				0.001	0.0022

CONTROL LEVER

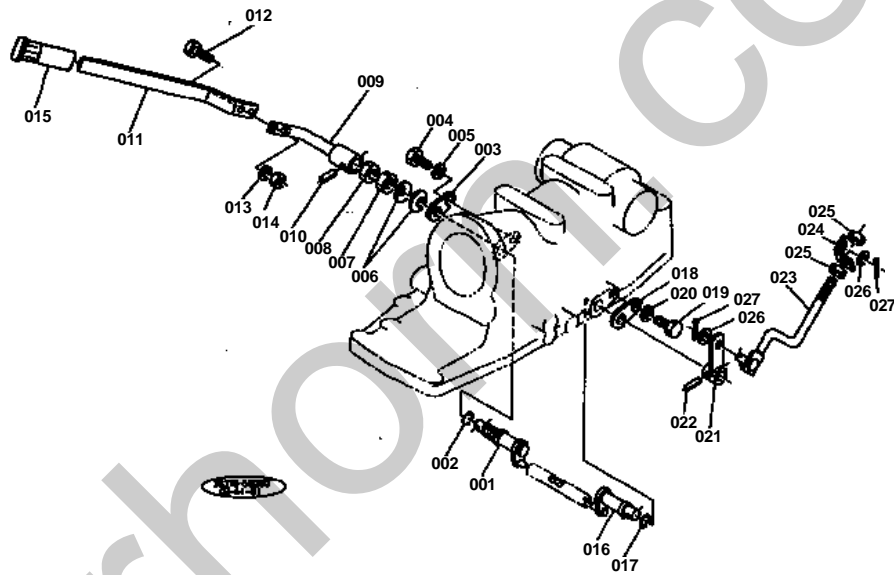



CONTROL LEVER

↔ Interchangeable; ≠ not interchangeable; ← new for old; → old for new

REF.No	Part No.	Description	Q'ty	S.No.	I/C	REMARKS	Weight (kgf)	Weight (lb)
001	37150-37650	ARM,CONTROL	1				0.11	0.242
002	04811-00110	O RING	1				0.001	0.0022
003	34260-36890	PLATE,SET	1				0.009	0.0198
004	01153-50816	BOLT	1				0.01	0.022
005	04512-50080	WASHER,SPRING	1				0.001	0.0022
006	34260-36880	SPRING	2				0.006	0.0132
007	02172-50140	NUT	1				0.01	0.022
008	02174-50140	NUT	1				0.014	0.0308
009	37300-36840	LEVER,CONTROL 1	1				0.195	0.429
010	05411-00525	PIN,SPRING	2				0.002	0.0044
011	35212-36850	LEVER,CONTROL 2	1				0.178	0.3916
012	01053-50616	BOLT	2				0.005	0.011
013	04512-50060	WASHER,SPRING	2				0	0
014	02056-50060	NUT	2				0.002	0.0044
015	34350-36890	GRIP,LEVER	1				0.016	0.0352
016	37150-37670	SHAFT,LEVER	1				0.085	0.187
017	04811-00110	O RING	1				0.001	0.0022
018	34260-36890	PLATE,SET	1				0.009	0.0198
019	01153-50816	BOLT	1				0.01	0.022
020	04512-50080	WASHER,SPRING	1				0.001	0.0022
021	37150-37680	LEVER,FEED BACK	1				0.05	0.11
022	05411-00420	PIN,SPRING	1				0.001	0.0022
023	37220-37690	ROD,FEED BACK	1				0.06	0.132
024	37220-37640	PLATE,CONTROL	1				0.025	0.055
025	02114-50080	NUT	2				0.005	0.011
026	04013-50080	WASHER,PLAIN	2				0	0
027	05511-50215	PIN,SPLIT	2				0.001	0.0022

LEVER GUIDE

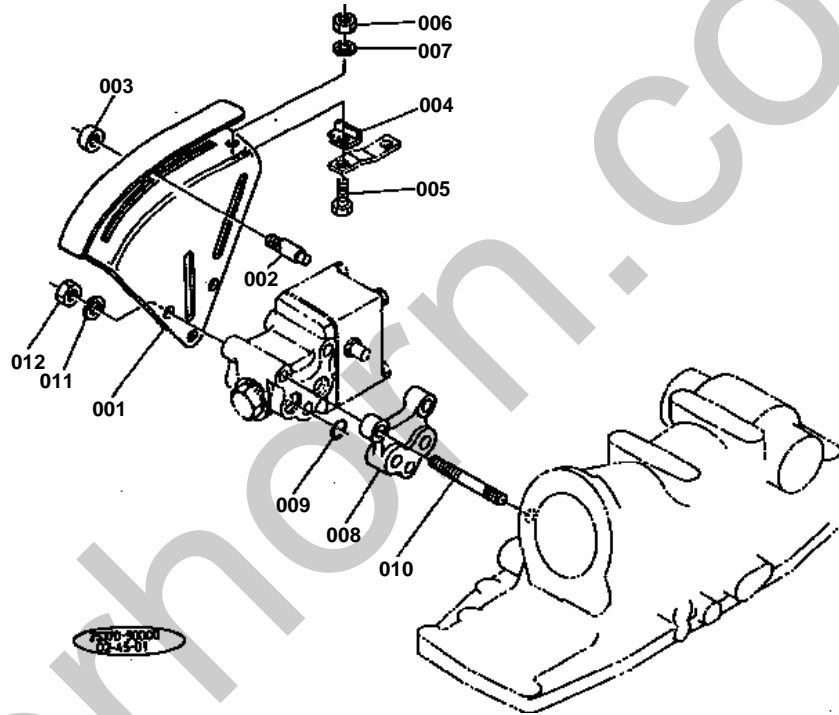



LEVER GUIDE

↔ Interchangeable; ≠ not interchangeable; ← new for old; → old for new

REF.No	Part No.	Description	Q'ty	S.No.	I/C	REMARKS	Weight (kgf)	Weight (lb)
001	37300-36860	GUIDE,O/P LEVER	1				0.985	2.167
002	37300-36910	STOPPER	1				0.05	0.11
003	37300-36920	NUT	1				0.046	0.1012
004	37300-36930	STOPPER	1				0.02	0.044
005	01170-51018	BOLT	1				0.017	0.0374
006	02118-50100	NUT	1				0.005	0.011
007	04512-50100	WASHER,SPRING	1				0	0
008	37300-41210	SPACER	1				0	0
009	04810-00160	O RING	2				0.001	0.0022
010	37300-41250	STUD	3				0.04	0.088
011	04512-50080	WASHER,SPRING	3				0.001	0.0022
012	02156-50080	NUT	3				0.004	0.0088

OIL HYDRAULIC CYLINDER

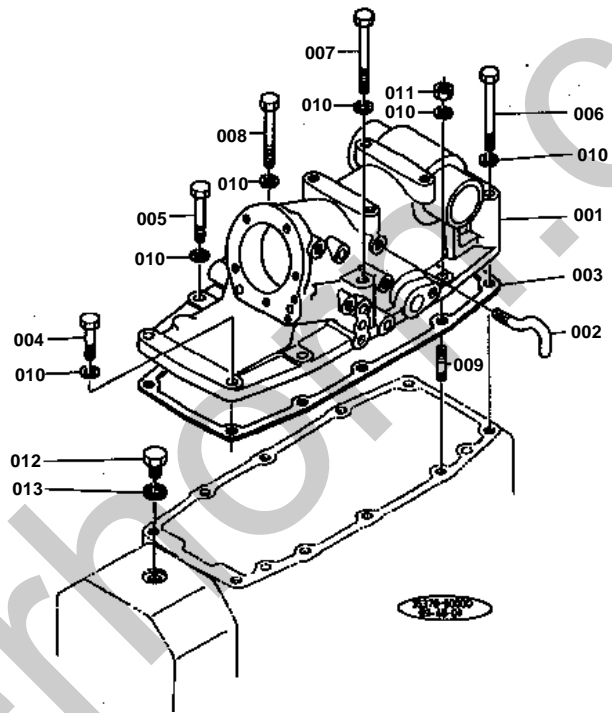



OIL HYDRAULIC CYLINDER

↔ Interchangeable; ≠ not interchangeable; ← new for old; → old for new

REF.No	Part No.	Description	Q'ty	S.No.	I/C	REMARKS	Weight (kgf)	Weight (lb)
001	35340-37110	CYLINDER,O/P	1				22.9	50.38
002	34260-37270	PIPE,BREATHER	1				0.03	0.066
003	37150-37120	PACKING	1				0	0
004	01173-51255	BOLT	2				0.057	0.1254
005	01173-51240	BOLT	2				0.045	0.099
006	34260-37180	BOLT	2				0.115	0.253
007	01173-51295	BOLT	1				0.086	0.1892
008	01173-51201	BOLT	1				0.094	0.2068
009	01574-51240	STUD	2				0	0
010	04512-50120	WASHER,SPRING	10				0	0
011	02176-50120	NUT	2				0.01	0.022
012	06311-45030	PLUG	1				0.06	0.132
013	04717-01700	WASHER,SEAL	1				0.003	0.0066

OIL HYDRAULIC CYLINDER COVER

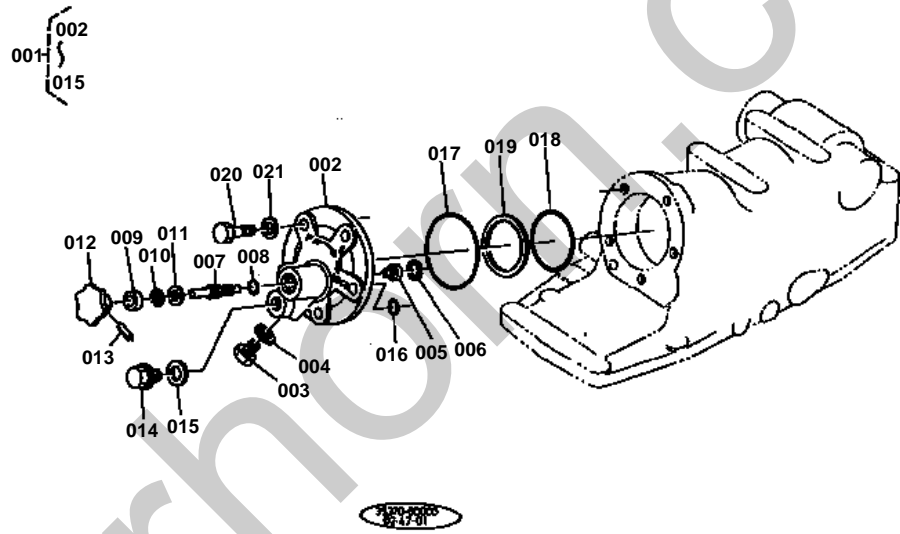



OIL HYDRAULIC CYLINDER COVER

↔ Interchangeable; ≠ not interchangeable; ← new for old; → old for new

REF.No	Part No.	Description	Q'ty	S.No.	I/C	REMARKS	Weight (kgf)	Weight (lb)
001	37300-37200	ASSY COVER,O/P CYL.	1				3.7	8.14
002	99999-99999	BLANK	0			ORDER BY REF.No.001	0	0
003	37150-36740	PLUG	1				0.025	0.055
004	04724-00100	PACKING	1				0.001	0.0022
005	34150-37250	COLLAR,ADJUSTING	1				0.01	0.022
006	04611-00180	CIR-CLIP,INTERNAL	1				0.001	0.0022
007	34150-37220	SCREW,ADJUSTING	1				0.025	0.055
008	04810-00100	O RING	1				0.001	0.0022
009	09230-08164	SEAL,OIL	1				0.001	0.0022
010	34150-37260	CIR-CLIP,INTERNAL	1				0.001	0.0022
011	04012-50080	WASHER,PLAIN	1				0.001	0.0022
012	34150-37230	GRIP	1				0.04	0.088
013	05411-00418	PIN,SPRING	1				0.001	0.0022
014	37150-36730	PLUG	1				0.03	0.066
015	37150-36720	PACKING	1				0.01	0.022
016	04810-00140	O RING	1				0.001	0.0022
017	04811-51000	O RING	1				0.003	0.0066
018	04810-50800	O RING	1				0.002	0.0044
019	37300-37260	RING,BACK UP	1				0.002	0.0044
020	01173-51240	BOLT	5				0.045	0.099
021	04512-50120	WASHER,SPRING	5				0	0

LIFT ARM

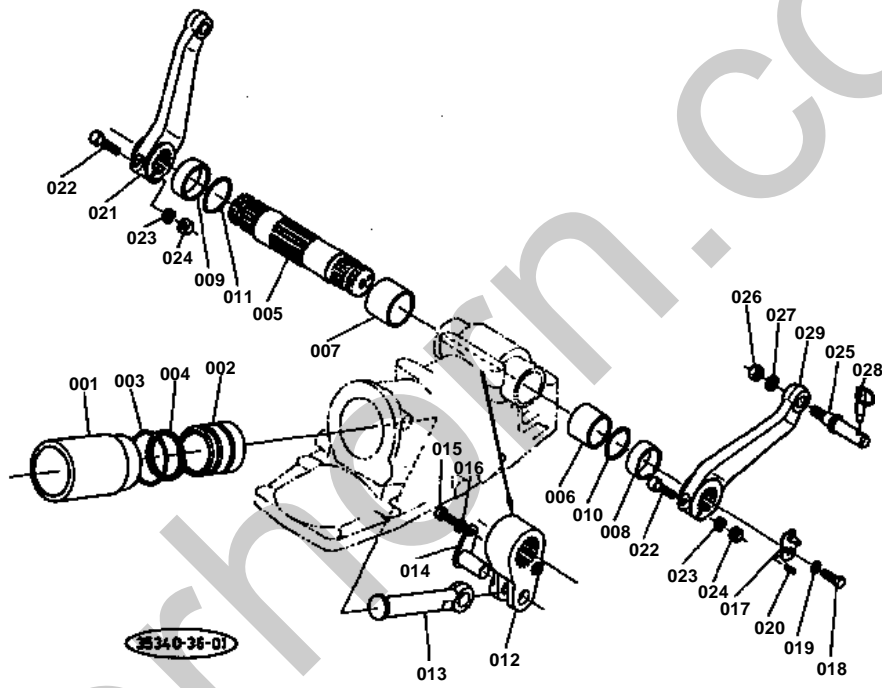

**LIFT ARM**

↔ Interchangeable; ≠ not interchangeable; ← new for old; → old for new

REF.No	Part No.	Description	Q'ty	S.No.	I/C	REMARKS	Weight (kgf)	Weight (lb)
001	37300-37130	LINER,CYLINDER	1				2.54	5.588
002	37300-37310	PISTON,O/P	1				1.76	3.872
003	04810-00750	O RING	2				0.003	0.0066
004	34350-37330	RING,BACK UP	1				0.004	0.0088
005	34260-37430	SHAFT,O/P ARM	1				3.2	7.04
006	32240-37450	BUSH	1				0	0
007	32240-37460	BUSH	1				0	0
008	37300-37480	COLLAR	1				0.01	0.022
009	37300-37490	COLLAR	1				0.01	0.022
010	04811-50450	O RING	1				0.002	0.0044
011	04811-50500	O RING	1				0.001	0.0022
012	37220-37440	ARM,OIL PRESSURE	1				1.71	3.762
013	37300-37320	ROD,OIL PRESSURE	1				0.5	1.1
014	32240-37340	PIN,SET	1				0.2	0.44
015	01173-51018	BOLT	1				0.018	0.0396
016	04512-50100	WASHER,SPRING	1				0	0
017	37300-37660	LINK,CONTROL	1				0.04	0.088
018	01170-51222	BOLT	1				0	0
019	04512-50120	WASHER,SPRING	1				0	0
020	05411-00414	PIN,SPRING	1				0.001	0.0022
021	35300-37610	ARM,LIFT RH	1				2.76	6.072
022	01173-51280	BOLT	2				0.1	0.22
023	04512-50120	WASHER,SPRING	2				0	0
024	02176-50120	NUT	2				0.01	0.022
025	32240-37695	PIN,LIFT ARM	2				0.2	0.44
026	02176-50160	NUT	2				0.021	0.0462
027	04512-50160	WASHER,SPRING	2				0	0
028	34150-37640	PIN,SET	2				0.06	0.132
029	35300-37620	ARM,LIFT LH	1				2.72	5.984

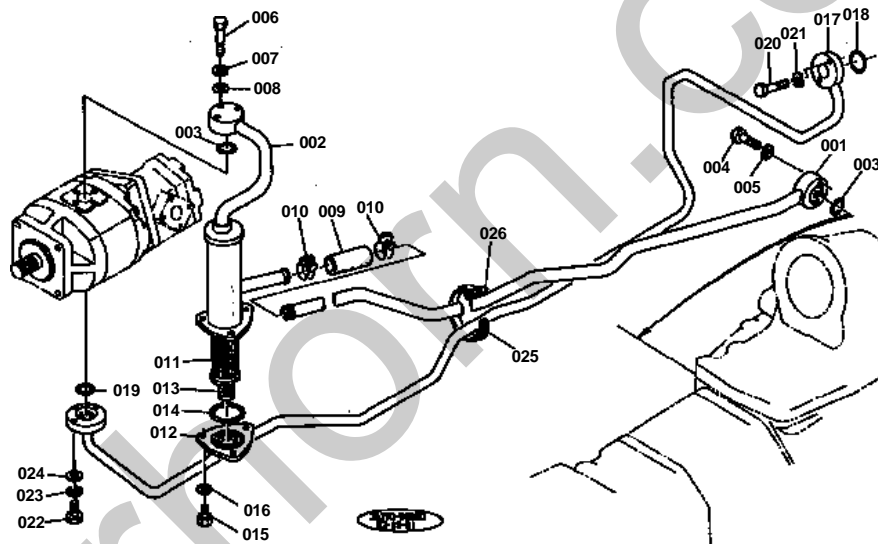



OIL HYDRAULIC PIPING

↔ Interchangeable; ≠ not interchangeable; ← new for old; → old for new

REF.No	Part No.	Description	Q'ty	S.No.	I/C	REMARKS	Weight (kgf)	Weight (lb)
001	35340-38110	PIPE,INLET	1				1.55	3.41
002	37810-38123	COMP CASE,FILTER	1				1.065	2.343
003	04811-00200	O RING	2				0.001	0.0022
004	01153-50850	BOLT	2				0.02	0.044
005	04512-50080	WASHER,SPRING	2				0.001	0.0022
006	01053-50642	BOLT	3				0.011	0.0242
007	04512-50060	WASHER,SPRING	3				0	0
008	04013-50060	WASHER,PLAIN	3				0	0
009	34350-37770	HOSE	1				0	0
010	34350-37780	CLAMP	2				0.02	0.044
011	37300-37710	FILTER,OIL	1				0.145	0.319
012	34350-37742	COVER,FILTER	1				0.319	0.7018
013	37300-37740	SPRING	1				0.005	0.011
014	04811-50600	O RING	1				0.002	0.0044
015	01153-50820	BOLT	3				0.012	0.0264
016	04512-50080	WASHER,SPRING	3				0.001	0.0022
017	35340-38210	COMP PIPE,DELIVERY	1				1.1	2.42
018	04810-00120	O RING	1				0.001	0.0022
019	04810-00200	O RING	1				0.001	0.0022
020	01153-50830	BOLT	2				0	0
021	04512-50080	WASHER,SPRING	2				0.001	0.0022
022	01053-50625	BOLT	3				0.007	0.0154
023	04512-50060	WASHER,SPRING	3				0	0
024	04013-50060	WASHER,PLAIN	3				0	0
025	33251-82760	BAND,O/P PIPE	2				0.016	0.0352
026	33430-82760	PIN	2				0.004	0.0088

FRONT DIFF GEAR CASE

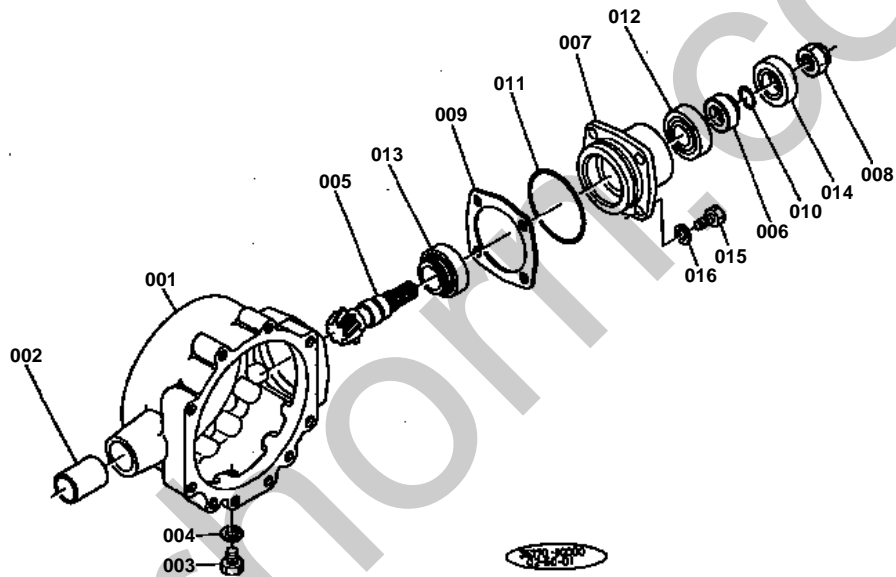



FRONT DIFF GEAR CASE

↔ Interchangeable; ≠ not interchangeable; ← new for old; → old for new

REF.No	Part No.	Description	Q'ty	S.No.	I/C	REMARKS	Weight (kgf)	Weight (lb)
001	37800-43110	CASE,DIFF GEAR	1				8.1	17.82
002	37800-44620	BUSH	1				0.09	0.198
003	06331-35012	PLUG	1				0.022	0.0484
004	04717-01200	WASHER,SEAL	1				0.002	0.0044
005	99999-99999	BLANK	0			ORDER BY REF.No.017	0	0
006	37800-43220	COLLAR	1				0.08	0.176
007	37800-43233	CASE,PINION BEARING	1				1.21	2.662
008	34150-25330	NUT	1				0.04	0.088
009	35350-43270	SHIM 0.2	3				0.01	0.022
009	35350-43280	SHIM 0.1	2				0.01	0.022
010	04811-00340	O RING	1				0.002	0.0044
011	04811-50800	O RING	1				0.003	0.0066
012	38630-43260	BEARING,TAPER ROLLER	1				0.24	0.528
013	38630-43292	BEARING,TAPER ROLLER	1				0.45	0.99
014	09500-45629	SEAL,OIL	1				0.023	0.0506
015	37800-43870	BOLT	4				0.026	0.0572
016	04512-50100	WASHER,SPRING	4				0	0
017	35350-43200	ASSY BEVEL	1			REF.No.005,REF.No.009 ON L.No.0D10-R0	3.25	7.15

FRONT DIFF CASE

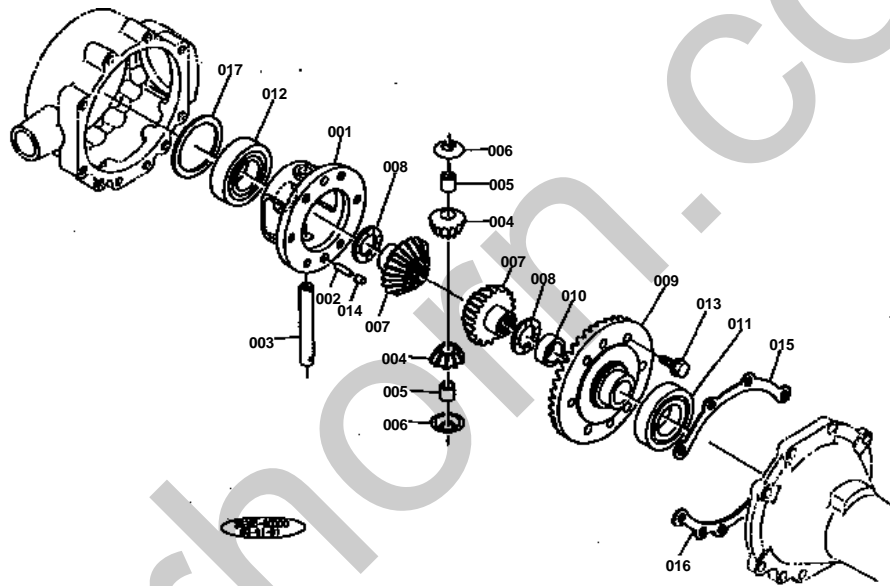



FRONT DIFF CASE

↔ Interchangeable; ≠ not interchangeable; ← new for old; → old for new

REF.No	Part No.	Description	Q'ty	S.No.	I/C	REMARKS	Weight (kgf)	Weight (lb)
001	38440-43310	CASE, DIFFERENTIAL	1				2.1	4.62
002	37650-43320	PIN,SNAP	1				0.01	0.022
003	37650-43330	SHAFT,DIFF PINION	1				0.3	0.66
004	31220-26300	PINION, DIFFERENTIAL	2				0.155	0.341
005	31220-26360	BUSH	2				0.015	0.033
006	31220-26390	WASHER,DIFF PINION	2				0	0
007	38440-44980	GEAR,DIFF SIDE RH	2				0	0
008	31220-26480	WASHER	2				0.015	0.033
008	31220-26490	WASHER	2				0.02	0.044
008	37150-26480	WASHER	2				0.016	0.0352
009	99999-99999	BLANK	0			ORDER BY REF.No.017 ON L.No.0D10-L0	0	0
010	37650-43360	BUSH	1				0.039	0.0858
011	08101-06211	BEARING,BALL	1				0.6	1.32
012	08101-06210	BEARING,BALL	1				0.45	0.99
013	37800-43870	BOLT	6				0.026	0.0572
014	38440-43880	PIN,STRAIGHT	2				0	0
015	37800-43180	SHIM 0.2 UPPER	2				0.004	0.0088
015	37800-43190	SHIM 0.1 UPPER	2				0.005	0.011
016	37800-43130	SHIM 0.2 UNDER	2				0.005	0.011
016	37800-43160	SHIM 0.1 UNDER	2				0.007	0.0154
017	37800-43140	SHIM 0.2	2				0.01	0.022
017	34160-43340	SHIM 0.1	2				0.003	0.0066

FRONT AXLE SUPPORT

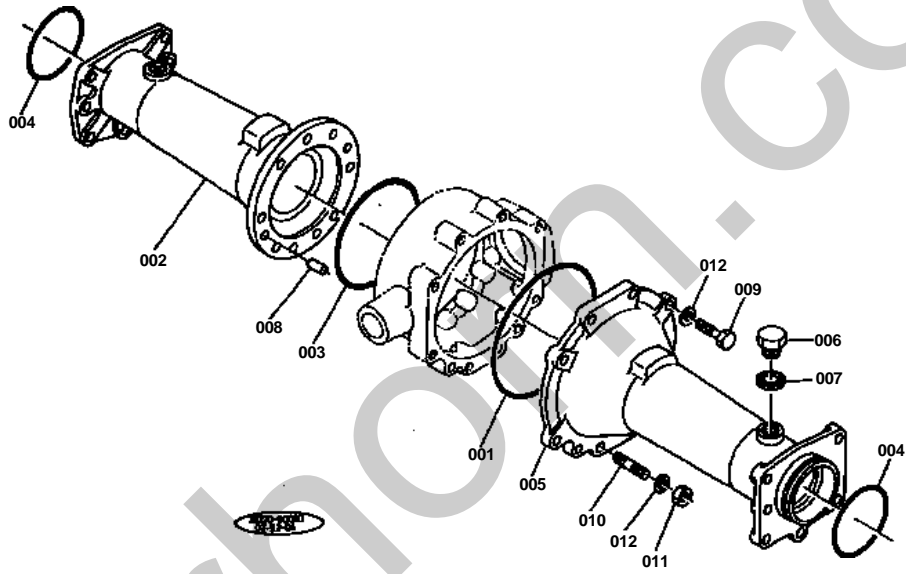



FRONT AXLE SUPPORT

↔ Interchangeable; ≠ not interchangeable; ← new for old; → old for new

REF.No	Part No.	Description	Q'ty	S.No.	I/C	REMARKS	Weight (kgf)	Weight (lb)
001	34160-43440	O RING	1				0.005	0.011
002	35350-43410	SUPPORT,FRONT AXLE R	1				11.3	24.86
003	04811-51450	O RING	2				0.005	0.011
004	04811-50900	O RING	2				0.003	0.0066
005	35350-43430	SUPPORT,FRONT AXLE L	1				10.9	23.98
006	06331-35020	PLUG	2				0.068	0.1496
007	04717-02000	WASHER,SEAL	2				0.004	0.0088
008	05012-01020	PIN,STRAIGHT	2				0.02	0.044
009	37800-43400	BOLT	13				0.043	0.0946
010	35230-43500	STUD	6				0.045	0.099
011	37800-43600	NUT	6				0.025	0.055
012	04512-50120	WASHER,SPRING	19				0	0

AXLE CASE

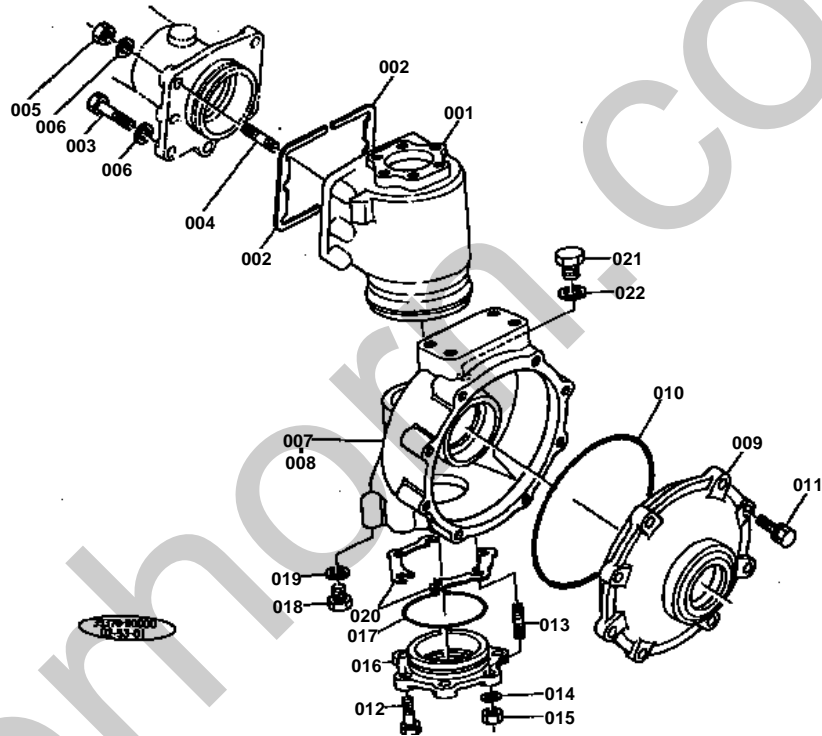

**AXLE CASE**

↔ Interchangeable; ≠ not interchangeable; ← new for old; → old for new

REF.No	Part No.	Description	Q'ty	S.No.	I/C	REMARKS	Weight (kgf)	Weight (lb)
001	38630-43440	CASE,BEVEL GEAR	2				5	11
002	38630-43450	SHIM 0.2	16				0.002	0.0044
002	38630-43560	SHIM 0.1	8				0.004	0.0088
003	37800-43400	BOLT	10				0.043	0.0946
004	37800-43500	STUD	4				0.045	0.099
005	37800-43600	NUT	4				0.025	0.055
006	04512-50120	WASHER,SPRING	14				0	0
007	35350-43510	CASE,AXLE LH	1				10.3	22.66
008	35350-43540	CASE,AXLE RH	1				10	22
009	38630-43520	FLANGE,AXLE	2				4	8.8
010	37800-43550	O RING	2				0.01	0.022
011	01123-50825	BOLT	16				0.013	0.0286
012	01133-51025	BOLT	8				0.023	0.0506
013	01517-51022	STUD	4				0	0
014	04512-50100	WASHER,SPRING	4				0	0
015	02176-50100	NUT	4				0.005	0.011
016	35350-43580	CASE,BEARING	2				0.855	1.881
017	04811-50900	O RING	2				0.003	0.0066
018	06331-35012	PLUG	2				0.022	0.0484
019	04717-01200	WASHER,SEAL	2				0.002	0.0044
020	35350-43590	SHIM 0.2	8				0.002	0.0044
020	35350-43570	SHIM 0.1	8				0.001	0.0022
021	06331-35020	PLUG	2				0.068	0.1496
022	04717-02000	WASHER,SEAL	2				0.004	0.0088

BEVEL GEAR SHAFT

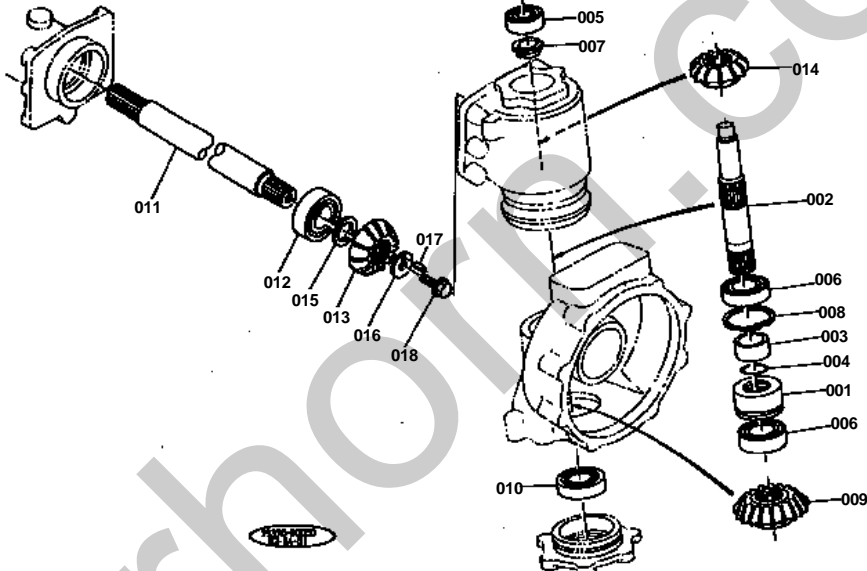



BEVEL GEAR SHAFT

↔ Interchangeable; ≠ not interchangeable; ← new for old; → old for new

REF.No	Part No.	Description	Q'ty	S.No.	I/C	REMARKS	Weight (kgf)	Weight (lb)
001	38630-43490	SEAL,OIL	2				0.12	0.264
002	38520-43460	SHAFT,BEVEL GEAR	2				2.1	4.62
003	38630-43480	COLLAR,SEAL	2				0.13	0.286
004	04811-50350	O RING	2				0.002	0.0044
005	08101-06305	BEARING,BALL	2				0.23	0.506
006	08241-05207	BEARING,BALL	4				0.458	1.0076
007	37800-43420	COLLAR,SPLIT	2				0.025	0.055
008	04611-00720	CIR-CLIP,INTERNAL	2				0.018	0.0396
009	38630-43650	GEAR,STR BEVEL 14	2				0.925	2.035
010	08101-06209	BEARING,BALL	2				0.42	0.924
011	35350-43810	SHAFT,DIFF YOKE	2				3.1	6.82
012	08101-06209	BEARING,BALL	2				0.42	0.924
013	35350-43820	GEAR,BEVEL 13	2				0.8	1.76
014	35350-43830	GEAR,BEVEL 15	2				0.84	1.848
015	37800-43840	COLLAR	2				0.012	0.0264
016	37800-43850	COLLAR	2				0.025	0.055
017	05411-00310	PIN,SPRING	2				0.001	0.0022
018	37800-43870	BOLT	2				0.026	0.0572

FRONT AXLE

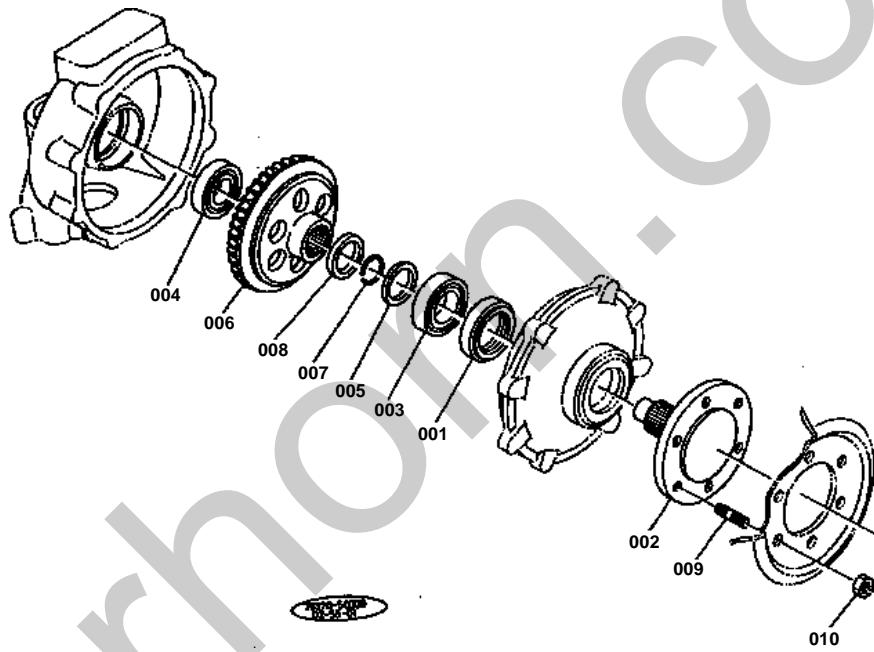



FRONT AXLE

↔ Interchangeable; ≠ not interchangeable; ← new for old; → old for new

REF.No	Part No.	Description	Q'ty	S.No.	I/C	REMARKS	Weight (kgf)	Weight (lb)
001	37800-43530	SEAL,OIL	2				0.098	0.2156
002	35350-43610	AXLE	2				5	11
003	08101-06209	BEARING,BALL	2				0.42	0.924
004	08101-06208	BEARING,BALL	2				0.355	0.781
005	37800-43670	COLLAR,THRUST	2				0.03	0.066
006	35350-43660	GEAR,BEVEL 40	2				6.3	13.86
007	37800-43680	CLIP	4				0	0
008	37800-43690	RETAINER,CLIP	2				0.03	0.066
009	01517-51425	STUD	12				0.047	0.1034
010	35340-11390	NUT	12				0.03	0.066

TIE ROD

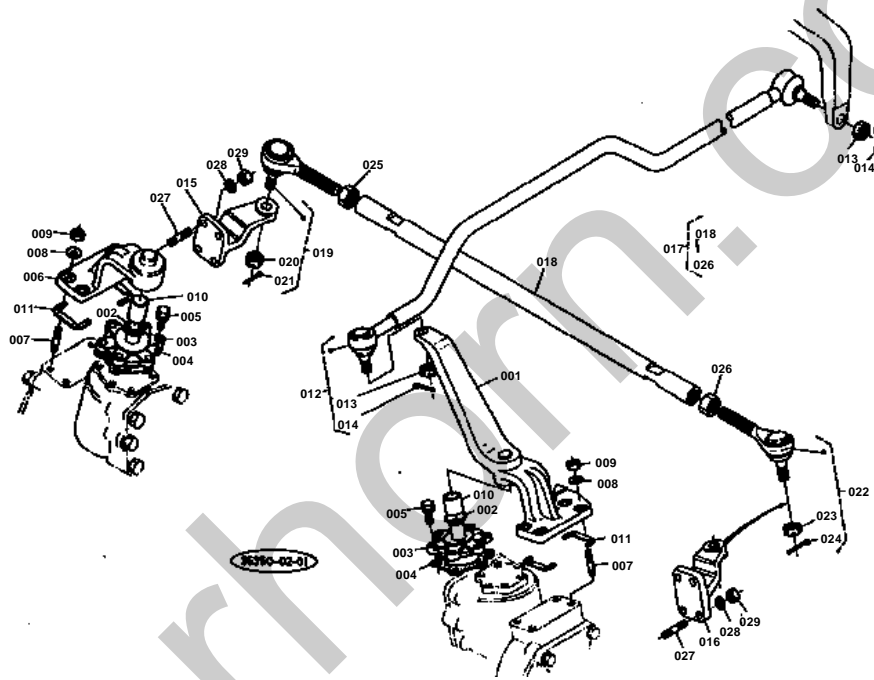

**TIE ROD**

↔ Interchangeable; ≠ not interchangeable; ← new for old; → old for new

REF.No	Part No.	Description	Q'ty	S.No.	I/C	REMARKS	Weight (kgf)	Weight (lb)
001	35350-43910	END,DRAG LINK	1				2.85	6.27
002	04811-00260	O RING	2				0.001	0.0022
003	37800-43920	PIN, KNUCKLE	2				0.536	1.1792
004	37800-43980	GASKET	2				0.005	0.011
005	01123-50822	BOLT	12				0.012	0.0264
006	35350-43900	SUPPORT, KNUCKLE RH	1				1.705	3.751
007	01574-51228	STUD	8				0.035	0.077
008	35340-27370	WASHER, SPRING	8				0.015	0.033
009	02176-50120	NUT	8				0.01	0.022
010	37800-43890	BUSH	2				0.035	0.077
011	35350-43860	SHIM 0.2	12				0.001	0.0022
012	35350-43960	ASSY LINK, DRAG	1				4.07	8.954
013	35270-12670	NUT, SLOTTED	2				0.014	0.0308
014	05511-50328	PIN, SPLIT	2				0.002	0.0044
015	37800-43943	ARM, KNUCKLE RH	1				0.92	2.024
016	37800-43950	ARM, KNUCKLE LH	1				0	0
017	35350-44040	ASSY ROD, TIE	1				3.3	7.26
018	35350-44000	ROD, TIE	1				2.37	5.214
019	38630-44780	ASSY END, TIE ROD RH	1				0.47	1.034
020	38430-12440	NUT, SLOTTED	1				0.015	0.033
021	05511-50325	PIN, SPLIT	1				0.002	0.0044
022	38630-44790	ASSY END, TIE ROD LH	1				0.47	1.034
023	38430-12440	NUT, SLOTTED	1				0.015	0.033
024	05511-50325	PIN, SPLIT	1				0.002	0.0044
025	02172-50200	NUT	1				0.03	0.066
026	38630-44980	NUT 20	1				0.01	0.022
027	01517-51035	STUD	8				0.028	0.0616
028	04512-50100	WASHER, SPRING	8				0	0
029	37300-14190	NUT	8				0.009	0.0198

FRONT AXLE BRACKET

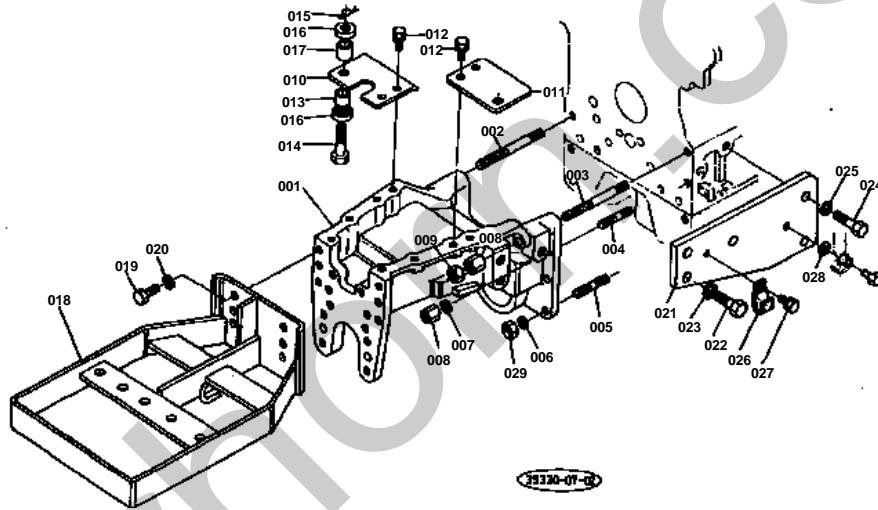



FRONT AXLE BRACKET

↔ Interchangeable; ≠ not interchangeable; ← new for old; → old for new

REF.No	Part No.	Description	Q'ty	S.No.	I/C	REMARKS	Weight (kgf)	Weight (lb)
001	35350-44713	BRACKET,FRONT AXLE	1				19	41.8
002	35340-13640	STUD	2				0.076	0.1672
003	35350-13630	STUD	1				0.09	0.198
004	01519-51030	STUD	1				0.025	0.055
005	01574-51232	STUD	4				0.039	0.0858
006	04512-50120	WASHER,SPRING	4				0	0
007	04512-50100	WASHER,SPRING	2				0	0
008	37300-14190	NUT	3				0.009	0.0198
009	02116-50100	NUT	1				0.004	0.0088
010	35340-13750	SUPPORT,RADIATOR RH	1				0.33	0.726
011	37300-13760	SUPPORT,RADIATOR LH	1				0.36	0.792
012	01130-51020	BOLT	4				0	0
013	15111-72180	CUSHION	2				0.015	0.033
014	15108-72380	BOLT	2				0.04	0.088
015	05515-51000	PIN,SNAP	2				0	0
016	15111-72200	WASHER	4				0.013	0.0286
017	15111-72190	CUSHION	2				0.016	0.0352
018	35300-13810	BUMPER	1				12.5	27.5
019	01173-51225	BOLT	6				0.033	0.0726
020	04512-50120	WASHER,SPRING	8				0	0
021	35350-44720	PLATE,REINFORCING	1				1.44	3.168
022	01173-51430	BOLT	3				0.052	0.1144
023	04512-50140	WASHER,SPRING	3				0	0
024	01176-51235	BOLT	2				0.041	0.0902
025	04512-50120	WASHER,SPRING	2				0	0
026	34150-29390	CLAMP,CORD	1				0.004	0.0088
027	01120-50814	BOLT	1				0	0
028	04011-50120	WASHER,PLAIN	1				0.005	0.011
029	02176-50120	NUT	4				0.01	0.022

CENTER PIN

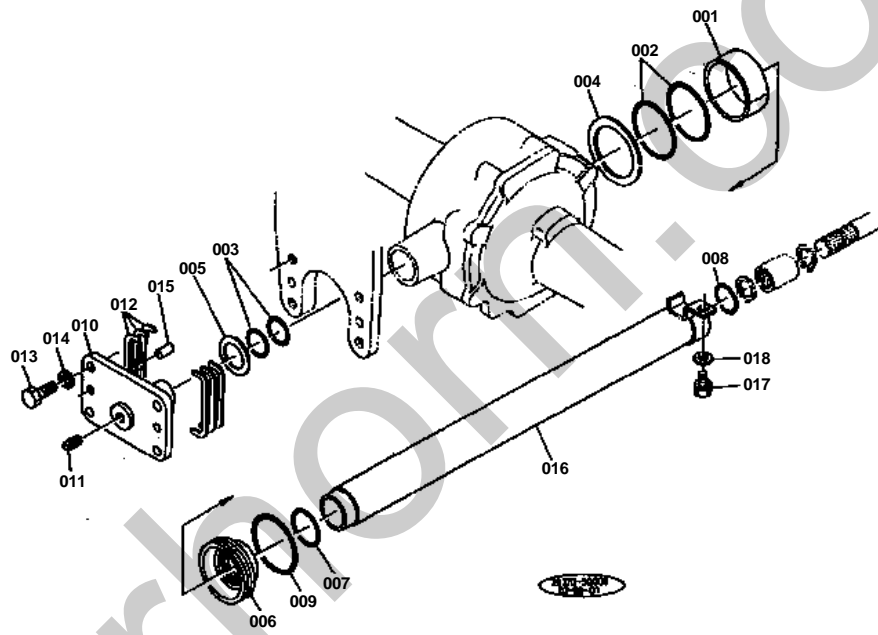

**CENTER PIN**

↔ Interchangeable; ≠ not interchangeable; ← new for old; → old for new

REF.No	Part No.	Description	Q'ty	S.No.	I/C	REMARKS	Weight (kgf)	Weight (lb)
001	37800-44630	BUSH	1				0.116	0.2552
002	04811-50750	O RING	2				0.002	0.0044
003	04811-50350	O RING	2				0.002	0.0044
004	37800-44640	COLLAR,THRUST	1				0.045	0.099
005	37800-44672	COLLAR,THRUST	1				0.05	0.11
006	37800-44580	COVER,SEAL	1				0.345	0.759
007	04811-00420	O RING	1				0.002	0.0044
008	04811-50350	O RING	1				0.002	0.0044
009	04811-50750	O RING	1				0.002	0.0044
010	37800-44610	PIN,CENTER	1				0	0
011	06312-10010	PLUG	1				0.007	0.0154
012	37800-44650	SHIM 0.2	20				0.003	0.0066
012	37800-44660	SHIM 1	2				0.01	0.022
013	37800-43400	BOLT	4				0.043	0.0946
014	04512-50120	WASHER,SPRING	4				0	0
015	05012-01025	PIN,STRAIGHT	2				0.016	0.0352
016	37880-44590	COVER 2	1				0.81	1.782
017	01130-51020	BOLT	1				0	0
018	04013-50100	WASHER,PLAIN	1				0	0

PROPELLER SHAFT

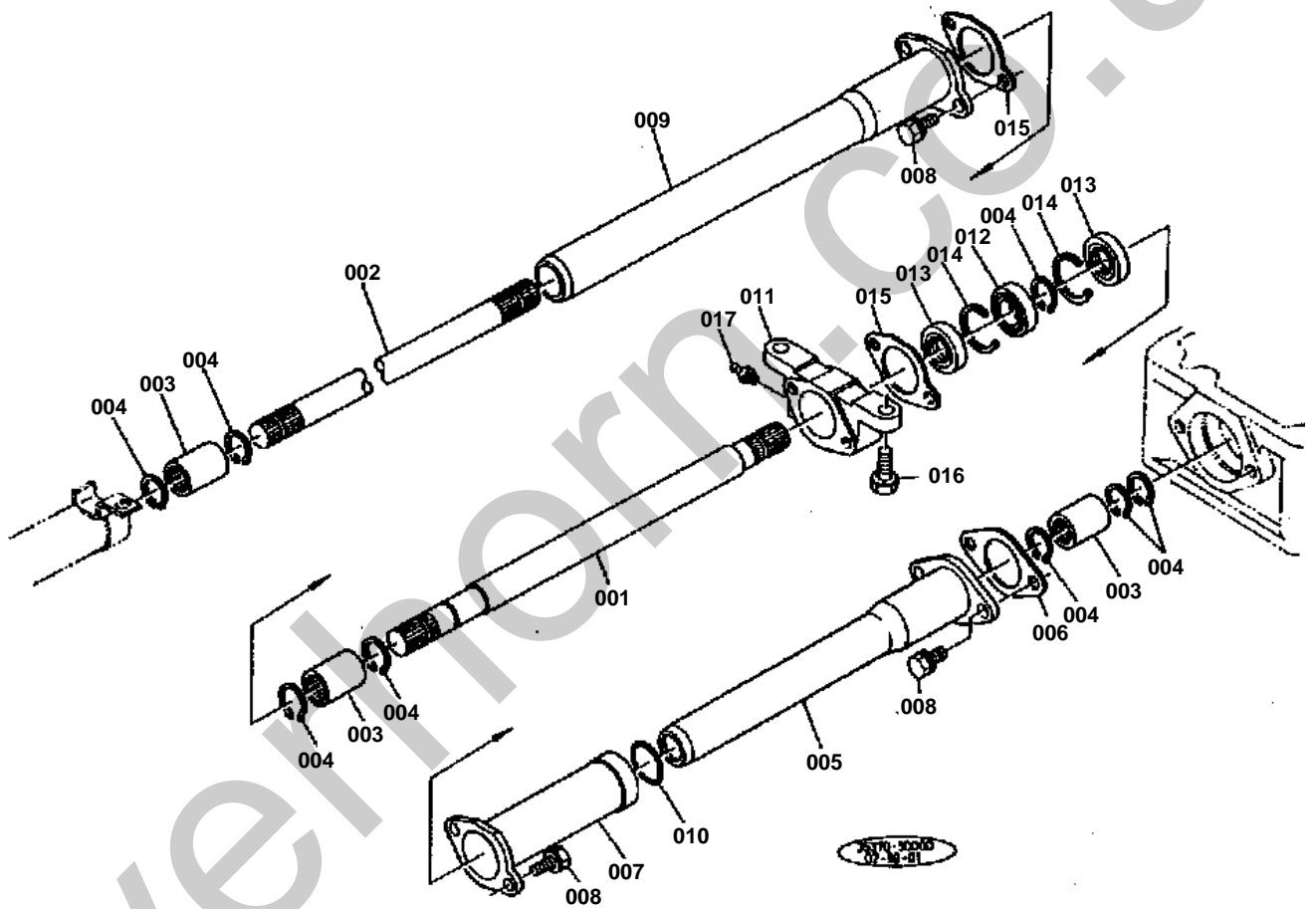



PROPELLER SHAFT

↔ Interchangeable; ≠ not interchangeable; ← new for old; → old for new

REF.No	Part No.	Description	Q'ty	S.No.	I/C	REMARKS	Weight (kgf)	Weight (lb)
001	35350-44510	SHAFT,PROPELLER 1	1				1.98	4.356
002	35350-44530	SHAFT,PROPELLER 2	1				3	6.6
003	37800-44520	COUPLING	3				0.16	0.352
004	04612-00250	CIR-CLIP,EXTERNAL	8				0.002	0.0044
005	35350-44570	COVER 1	1				0.585	1.287
006	37650-44540	GASKET	1				0	0
007	35350-44550	COVER 3	1				0.34	0.748
008	01120-50816	BOLT	6				0	0
009	35350-44560	COVER 4	1				0.775	1.705
010	04811-50350	O RING	1				0.002	0.0044
011	35350-44630	CASE,BEARING	1				0.58	1.276
012	08101-06905	BEARING,BALL	1				0.04	0.088
013	09500-25428	SEAL,OIL	2				0.016	0.0352
014	35350-44650	COLLAR	2				0.005	0.011
015	35350-44660	GASKET	2				0	0
016	01133-51230	BOLT	2				0.04	0.088
017	06613-10675	NIPPLE,GREASE	1				0.003	0.0066

DRIVE CASE

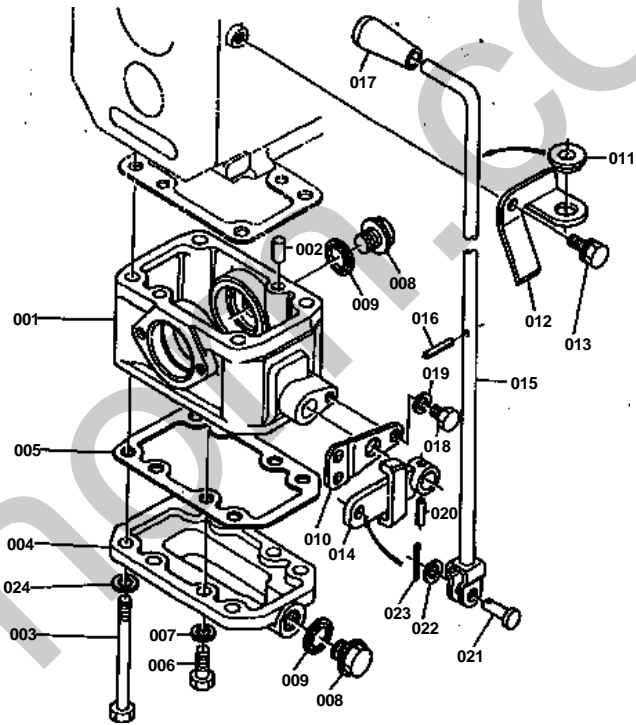

**DRIVE CASE**

↔ Interchangeable; ≠ not interchangeable; ← new for old; → old for new

REF.No	Part No.	Description	Q'ty	S.No.	I/C	REMARKS	Weight (kgf)	Weight (lb)
001	37800-44110	CASE	1				3.6	7.92
002	05012-01018	PIN,STRAIGHT	2				0.012	0.0264
003	37800-44120	BOLT	4				0.11	0.242
004	37800-44130	COVER	1				1.11	2.442
005	37800-44140	PACKING	1				0.007	0.0154
006	01173-51028	BOLT	4				0.022	0.0484
007	04512-50100	WASHER,SPRING	4				0	0
008	34150-14260	PLUG,DRAIN	2				0	0
009	04717-02150	WASHER,SEAL	2				0.004	0.0088
010	37800-44350	GUIDE,LEVER	1				0.042	0.0924
011	37800-44390	RUBBER	1				0.005	0.011
012	37800-44380	SUPPORT,LEVER	1				0.1	0.22
013	01130-51020	BOLT	1				0	0
014	35310-44360	LEVER,CHANGE	1				0.21	0.462
015	37800-44400	LEVER	1				0.515	1.133
016	05411-00430	PIN,SPRING	1				0.002	0.0044
017	54201-23270	GRIP	1				0.02	0.044
018	01153-50814	BOLT	1				0.009	0.0198
019	04512-50080	WASHER,SPRING	1				0.001	0.0022
020	05411-00625	PIN,SPRING	1				0.004	0.0088
021	05122-51022	PIN,JOINT	1				0.014	0.0308
022	04013-50100	WASHER,PLAIN	1				0	0
023	05511-50318	PIN,SPLIT	1				0.001	0.0022
024	04512-50120	WASHER,SPRING	4				0	0

DRIVE SHAFT

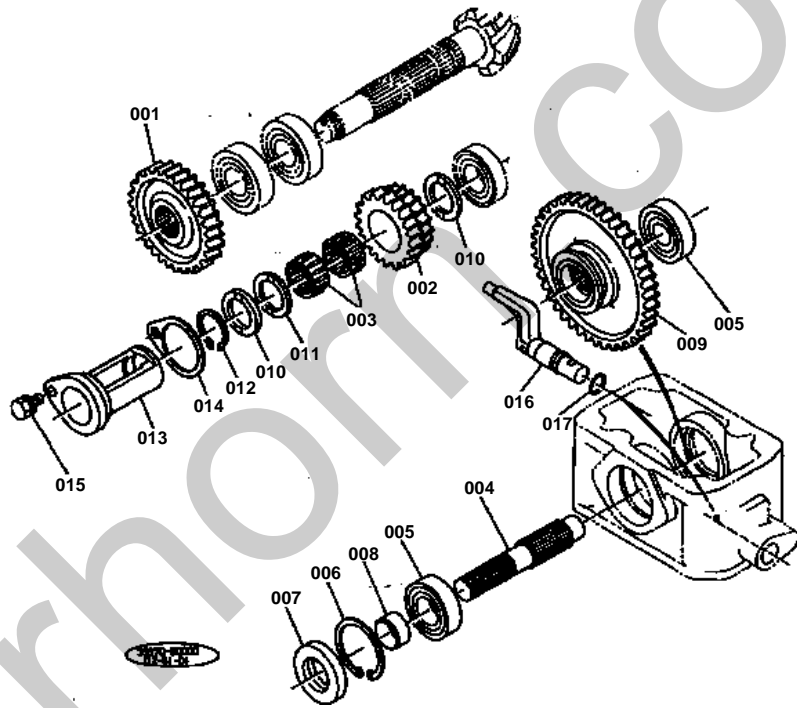



DRIVE SHAFT

↔ Interchangeable; ≠ not interchangeable; ← new for old; → old for new

REF.No	Part No.	Description	Q'ty	S.No.	I/C	REMARKS	Weight (kgf)	Weight (lb)
001	35370-44150	GEAR,SPUR 27	1				0.605	1.331
002	35370-44180	GEAR,SPUR 15-21	1				0.405	0.891
003	08823-03614	BEARING,NEEDLE	2				0.022	0.0484
004	37800-44190	SHAFT,PTO	1				0.598	1.3156
005	08101-06205	BEARING,BALL	2				0.14	0.308
006	04611-00520	CIR-CLIP,INTERNAL	1				0.009	0.0198
007	09503-05211	SEAL,OIL	1				0.022	0.0484
008	37800-44210	SLEEVE	1				0.015	0.033
009	35350-44230	GEAR,SPUR 48	1				1.4	3.08
010	35340-21760	COLLAR,THRUST	2				0.01	0.022
011	35340-21560	WASHER	1				0.008	0.0176
012	37880-44270	CIR-CLIP,EXTERNAL	1				0	0
013	35350-44280	STOPPER	1				0.5	1.1
014	35350-44290	SHIM	1				0.005	0.011
015	01123-50820	BOLT	1				0.011	0.0242
016	37800-44310	LEVER,SHIFT	1				0.146	0.3212
017	04811-00150	O RING	1				0.001	0.0022

3-POINT LINK 1

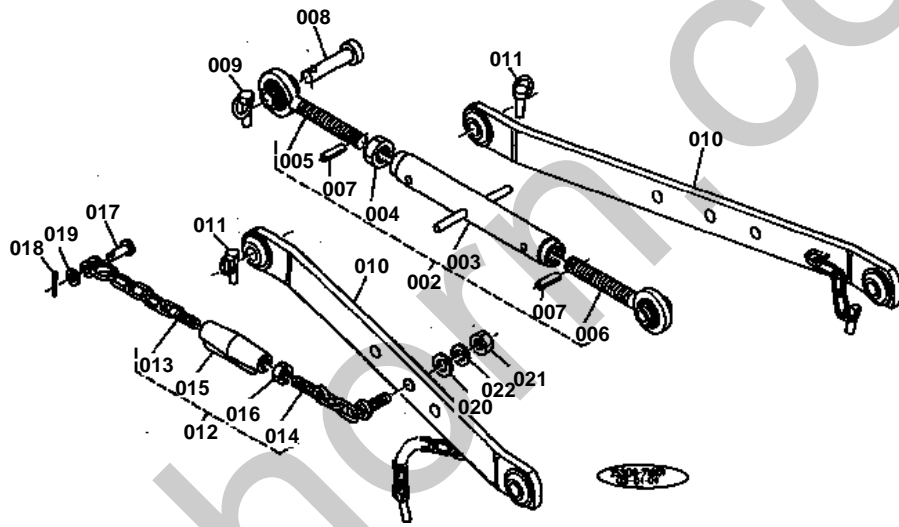



3-POINT LINK 1

↔ Interchangeable; ≠ not interchangeable; ← new for old; → old for new

REF.No	Part No.	Description	Q'ty	S.No.	I/C	REMARKS	Weight (kgf)	Weight (lb)
001	99999-99999	BLANK	0				0	0
002	37307-71100	ASSY LINK,TOP	1				0	0
003	32244-71110	LINK,TOP	1				1.01	2.222
004	32244-71180	NUT,TOP LINK	1				0.057	0.1254
005	37307-71210	JOINT,TOP LINK 1	1				1.05	2.31
006	37307-71220	JOINT,TOP LINK 2	1				1.065	2.343
007	05411-00425	PIN,SPRING	2				0.001	0.0022
008	37307-71360	PIN,JOINT	2				0	0
009	34150-37640	PIN,SET	2				0.06	0.132
010	37267-71310	LINK,LOWER	2				8.4	18.48
011	34150-37640	PIN,SET	2				0.06	0.132
012	37267-71800	ASSY CHAIN,CHECK	2				2.1	4.62
013	37267-71810	CHAIN,CHECK 1	2				0.665	1.463
014	37307-71820	CHAIN,CHECK 2	2				0.775	1.705
015	36200-91190	TURNBUCKLE	2				0.63	1.386
016	02154-50160	NUT	2				0.025	0.055
017	32353-71890	PIN	2				0.041	0.0902
018	05511-50425	PIN,SPLIT	2				0.003	0.0066
019	04013-50120	WASHER,PLAIN	2				0	0
020	37307-71830	WASHER	2				0.29	0.638
021	02174-50180	NUT	2				0.029	0.0638
022	04512-50180	WASHER,SPRING	2				0	0

3-POINT LINK 2

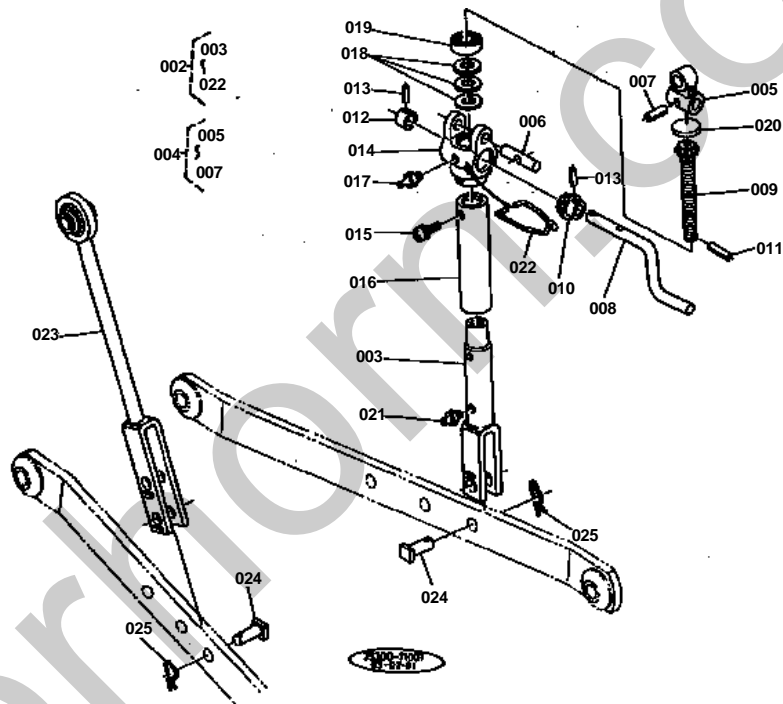



3-POINT LINK 2

↔ Interchangeable; ≠ not interchangeable; ← new for old; → old for new

REF.No	Part No.	Description	Q'ty	S.No.	I/C	REMARKS	Weight (kgf)	Weight (lb)
001	99999-99999	BLANK	0				0	0
002	37267-71560	ASSY ADJUSTER,LIFT R	1				3.8	8.36
003	37267-71520	ROD,LIFT UNDER	1				0.955	2.101
004	38247-71590	ASSY JOINT,GEAR CASE	1				0	0
005	38247-71570	JOINT GEAR CASE	1				0	0
006	38247-71550	PIN,LIFT ROD	1				0.11	0.242
007	05411-00532	PIN,SPRING	1				0.003	0.0066
008	32244-71610	HANDLE,LIFT ROD	1				0.229	0.5038
009	32244-71640	GEAR,LIFT ROD 1	1				0.4	0.88
010	32244-71650	GEAR,LIFT ROD 2	1				0.126	0.2772
011	05411-00420	PIN,SPRING	1				0.001	0.0022
012	32244-71670	COLLAR	1				0.027	0.0594
013	05411-00622	PIN,SPRING	2				0.003	0.0066
014	34264-71710	CASE,LIFT ROD GEAR	1				0	0
015	01202-50612	BOLT	1				0.005	0.011
016	34264-71704	PIPE	1				0.49	1.078
017	06613-10675	NIPPLE,GREASE	1				0.003	0.0066
018	31220-71720	SHIM	3				0.001	0.0022
019	32294-71770	BEARING,THRUST BALL	1				0.073	0.1606
020	06311-75045	PLUG,EXPANSION	1				0.026	0.0572
021	06613-10675	NIPPLE,GREASE	1				0.003	0.0066
022	32244-71730	STOPPER	1				0.027	0.0594
023	37267-71540	ROD,LIFT,LH	1				1.81	3.982
024	34354-71580	PIN	2				0.09	0.198
025	05515-51600	PIN,SNAP	2				0.007	0.0154

POWER STEERING

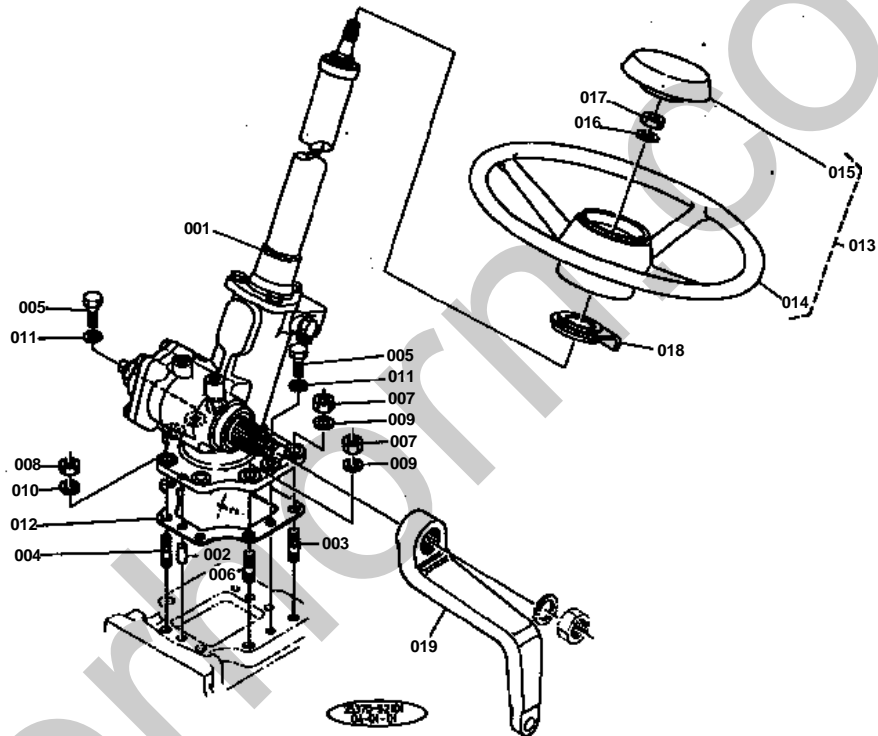



POWER STEERING

↔ Interchangeable; ≠ not interchangeable; ← new for old; → old for new

REF.No	Part No.	Description	Q'ty	S.No.	I/C	REMARKS	Weight (kgf)	Weight (lb)
001	35350-16108	ASSY STEERING,POWER	1				20.9	45.98
002	37150-27370	PIN,SPLIT	2				0.009	0.0198
003	01574-51240	STUD	2				0	0
004	01517-51025	STUD	2				0	0
005	01153-50830	BOLT	2				0	0
006	01574-51225	STUD	2				0.034	0.0748
007	02174-50120	NUT	4				0.01	0.022
008	02118-50100	NUT	2				0.005	0.011
009	04512-50120	WASHER,SPRING	4				0	0
010	04512-50100	WASHER,SPRING	2				0	0
011	04512-50080	WASHER,SPRING	2				0.001	0.0022
012	35370-16800	PACKING	1				0.015	0.033
013	66611-41400	ASSY WHEEL,STEERING	1				0	0
014	99999-99999	BLANK	0			ORDER BY REF.No.013	0	0
015	66611-41420	CAP,STEERING WHEEL	1				0.026	0.0572
016	04512-50120	WASHER,SPRING	1				0	0
017	02174-50120	NUT	1				0.01	0.022
018	37300-16850	HOLDER,POST	1				0.025	0.055
019	35350-43930	ARM,PITMAN	1				2.94	6.468

OIL TANK

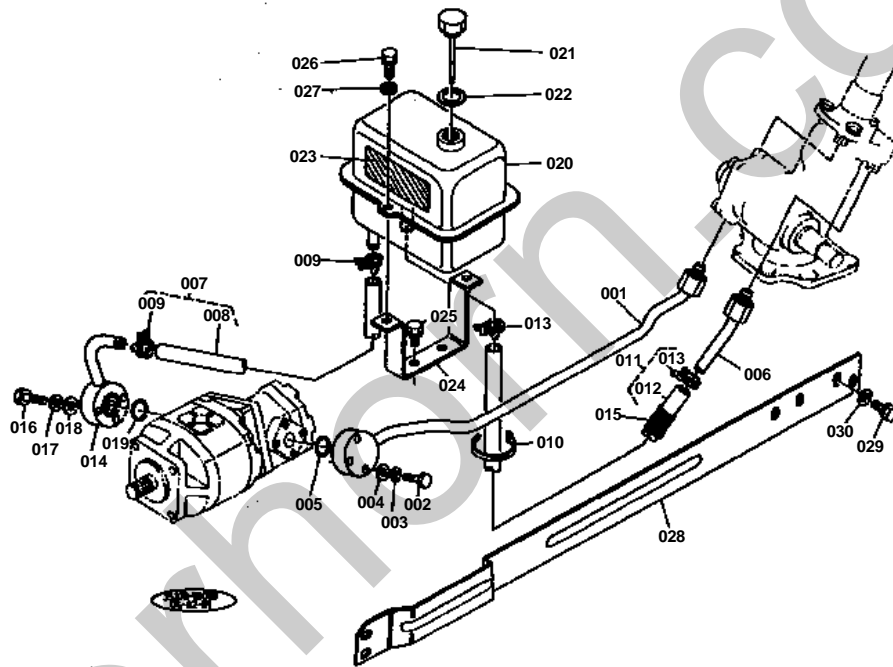



OIL TANK

↔ Interchangeable; ≠ not interchangeable; ← new for old; → old for new

REF.No	Part No.	Description	Q'ty	S.No.	I/C	REMARKS	Weight (kgf)	Weight (lb)
001	35370-16720	COMP PIPE	1				0.42	0.924
002	01053-50635	BOLT	3				0.009	0.0198
003	04512-50060	WASHER,SPRING	3				0	0
004	04013-50060	WASHER,PLAIN	3				0	0
005	04810-00200	O RING	1				0.001	0.0022
006	38430-45300	ASSY PIPE,RETURN 1	1				0.065	0.143
007	38430-45100	ASSY PIPE,INLET	1				0.11	0.242
008	99999-99999	BLANK	0			ORDER BY REF.No.007	0	0
009	38430-45150	CLAMP	2				0.015	0.033
010	34350-29380	BAND,CORD	2				0.001	0.0022
011	38320-45350	ASSY PIPE,RETURN 2	1				0.2	0.44
012	99999-99999	BLANK	0			ORDER BY REF.No.011	0	0
013	38430-45150	CLAMP	2				0.015	0.033
014	35370-45180	FLANGE,PIPE	1				0.28	0.616
015	38430-45390	SPRING,PROTECTOR	1				0.045	0.099
016	01053-50635	BOLT	3				0.009	0.0198
017	04512-50060	WASHER,SPRING	3				0	0
018	04013-50060	WASHER,PLAIN	3				0	0
019	04810-00200	O RING	1				0.001	0.0022
020	38430-45223	TANK,OIL	1				1.2	2.64
021	37810-45260	GAUGE,PLUG	1				0.076	0.1672
022	04717-02000	WASHER,SEAL	1				0.004	0.0088
023	35340-45380	LABEL	1				0.005	0.011
024	38260-45450	STAY,TANK	1				0.405	0.891
025	01123-50820	BOLT	2				0.011	0.0242
026	01023-50616	BOLT	2				0.005	0.011
027	04013-50060	WASHER,PLAIN	2				0	0
028	35340-45370	FRAME UPPER 2	1				0.96	2.112
029	01123-50818	BOLT	4				0.012	0.0264
030	04013-50080	WASHER,PLAIN	4				0	0

FUEL TANK

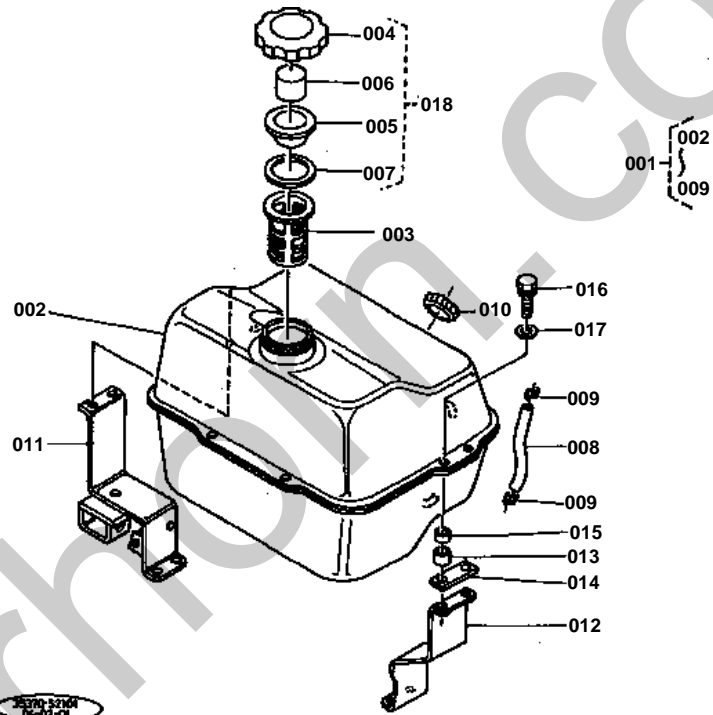



FUEL TANK

↔ Interchangeable; ≠ not interchangeable; ← new for old; → old for new

REF.No	Part No.	Description	Q'ty	S.No.	I/C	REMARKS	Weight (kgf)	Weight (lb)
001	35370-35100	ASSY TANK,FUEL	1				7	15.4
002	99999-99999	BLANK	0			ORDER BY REF.No.001	0	0
003	13251-41060	FILTER,FUEL	1				0.01	0.022
004	99999-99999	BLANK	0			ORDER BY REF.No.018	0	0
005	34150-35230	PACKING	1				0.01	0.022
006	34150-35240	SPONGE	1				0.001	0.0022
007	34150-35180	PACKING	1				0.001	0.0022
008	07935-05741	GAUGE,FUEL	1				0.16	0.352
009	10013-41770	CLIP,PIPE	2				0.005	0.011
010	37300-35550	BUSH	1				0.014	0.0308
011	35370-35280	STAY TANK,FUEL RH	1				1.47	3.234
012	35370-35290	STAY TANK,FUEL LH	1				0.925	2.035
013	37300-35140	SPACER	4				0.006	0.0132
014	37300-35130	CUSHION	2				0.007	0.0154
015	37300-35120	CUSHION	4				0.003	0.0066
016	01120-50830	BOLT	4				0	0
017	04015-50080	WASHER,PLAIN	4				0	0
018	38240-35200	ASSY CAP	1				0.06	0.132

SWING DRAWBAR

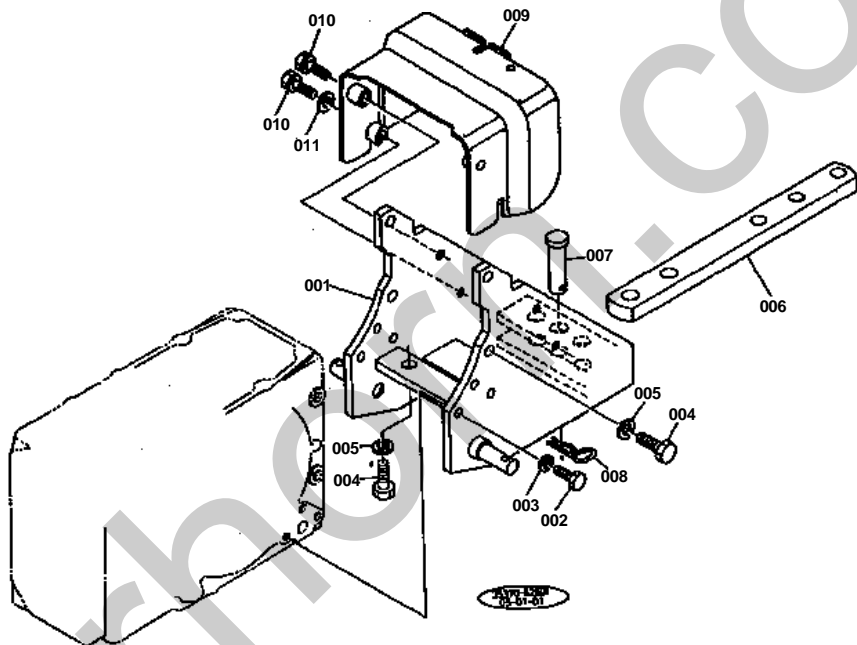



SWING DRAWBAR

↔ Interchangeable; ≠ not interchangeable; ← new for old; → old for new

REF.No	Part No.	Description	Q'ty	S.No.	I/C	REMARKS	Weight (kgf)	Weight (lb)
001	35370-29710	BRACKET,HITCH	1				21.5	47.3
002	01176-51232	BOLT	6				0.041	0.0902
003	04512-50120	WASHER,SPRING	6				0	0
004	01176-51435	BOLT	6				0.056	0.1232
005	04512-50140	WASHER,SPRING	6				0	0
006	99553-78210	DRAWBAR 1	1				5.84	12.848
007	37300-29780	PIN,JOINT	3				0.31	0.682
008	70515-16330	PIN,SPRING	3				0.028	0.0616
009	35370-25420	PROTECTOR,PTO	1				2.6	5.72
010	01133-51040	BOLT	4				0.03	0.066
011	04013-50100	WASHER,PLAIN	2				0	0

TAIL LAMP

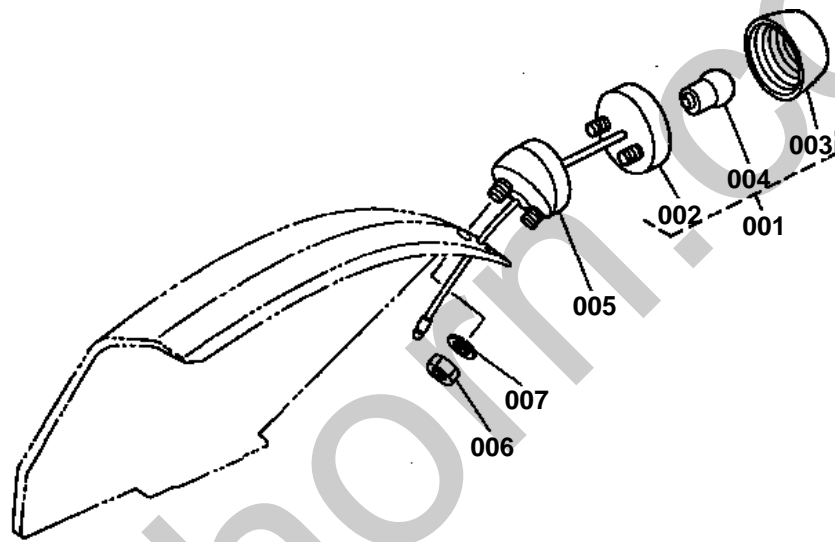

35170-53501
28-01-01



TAIL LAMP

↔ Interchangeable; ≠ not interchangeable; ← new for old; → old for new

REF.No	Part No.	Description	Q'ty	S.No.	I/C	REMARKS	Weight (kgf)	Weight (lb)
001	34350-34100	ASSY LAMP,TAIL	2				0.13	0.286
002	99999-99999	BLANK	0			ORDER BY REF.No.001	0	0
003	34350-34120	LENS,LAMP	2				0.05	0.11
004	34350-34140	BULB,LAMP	2				0.008	0.0176
005	34350-34190	HOLDER,TAIL LAMP	2				0.107	0.2354
006	02014-50060	NUT	4				0.003	0.0066
007	04512-50060	WASHER,SPRING	4				0	0

HAZARD LAMP

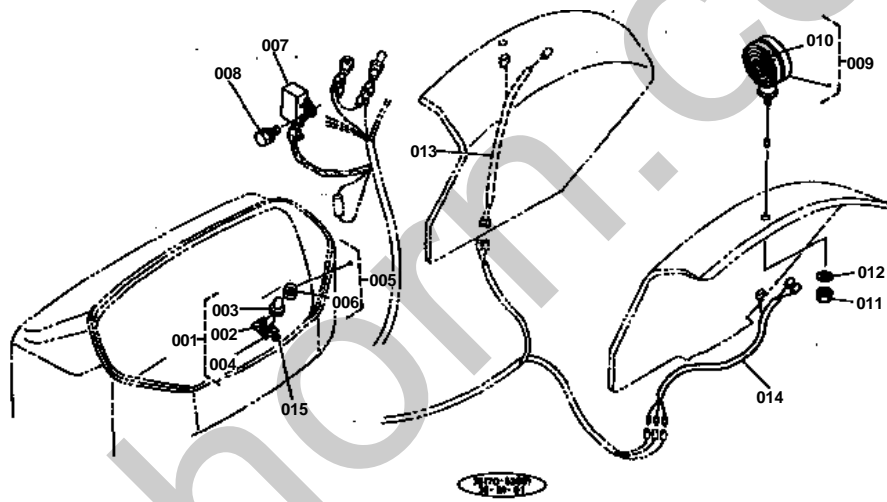



HAZARD LAMP

↔ Interchangeable; ≠ not interchangeable; ← new for old; → old for new

REF.No	Part No.	Description	Q'ty	S.No.	I/C	REMARKS	Weight (kgf)	Weight (lb)
001	54721-41300	ASSY SWITCH	1				0.03	0.066
002	99999-99999	BLANK	0			ORDER BY REF.No.001	0	0
003	54721-22330	CAP	1				0.002	0.0044
004	54721-22340	LABEL	1				0.001	0.0022
005	66711-55290	ASSY OIL LAMP	1				0.016	0.0352
006	34150-34590	BULB	1				0.001	0.0022
007	35170-33700	FLASHER	1				0.06	0.132
008	01202-50616	BOLT	1				0.006	0.0132
009	35450-75010	ASSY LAMP HAZARD FLA	2				0.3	0.66
010	35450-75022	VALVE HAZARD FLASHER	2				0.008	0.0176
011	02114-50100	NUT	2				0.005	0.011
012	04512-50100	WASHER,SPRING	2				0	0
013	35170-34360	WIRE HARNESS 6	1				0.025	0.055
014	35170-34370	WIRE HARNESS 7	1				0.035	0.077
015	35320-31840	LABEL	1				0.005	0.011

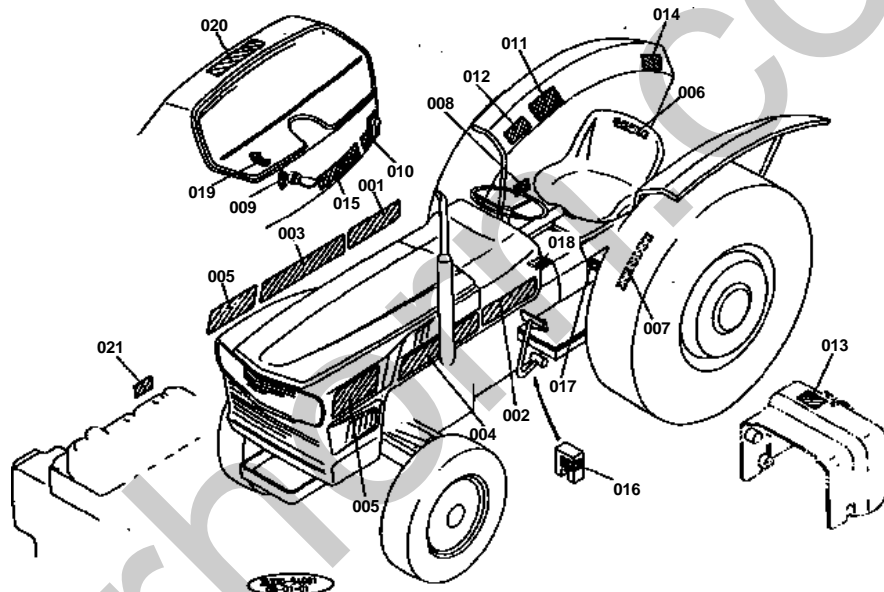

**LABEL**

↔ Interchangeable; ≠ not interchangeable; ← new for old; → old for new

REF.No	Part No.	Description	Q'ty	S.No.	I/C	REMARKS	Weight (kgf)	Weight (lb)
001	35370-18760	MARK,SIDE KUBOTA RH	1				0.007	0.0154
002	35370-18770	MARK,SIDE KUBOTA LH	1				0.015	0.033
003	35370-18780	MARK,FORM RH	1				0.02	0.044
004	35370-18790	MARK,FORM LH	1				0.02	0.044
005	35290-18810	LABEL,4WD	2				0.005	0.011
006	32140-18470	MARK,KUBOTA	1				0.002	0.0044
007	35340-24580	LABEL,AUX S-CHANGE	1				0.001	0.0022
008	35176-26690	LABEL,DIFF LOCK	1				0.001	0.0022
009	35176-31830	LABEL,MAIN SWITCH	1				0.001	0.0022
010	35176-32290	LABEL,STARTER SWITCH	1				0.005	0.011
011	35260-34910	LABEL,SAFETY	1				0	0
012	35260-29780	LABEL,ROPS INSTRUCTI	1				0	0
013	35260-25340	LABEL	1				0.005	0.011
014	35260-29790	LABEL	1				0.002	0.0044
015	35340-34920	LABEL,INSTRUCTION	1				0.025	0.055
016	35176-15930	LABEL,PEDAL	1				0.005	0.011
017	35350-44900	LABEL,CHANGE	1				0.001	0.0022
018	35370-31300	LABEL	1				0.001	0.0022
019	35370-31350	LABEL	1				0.001	0.0022
020	35370-31360	LABEL	1				0	0
021	15222-88210	LABEL,INSTRUCTION	1				0.003	0.0066

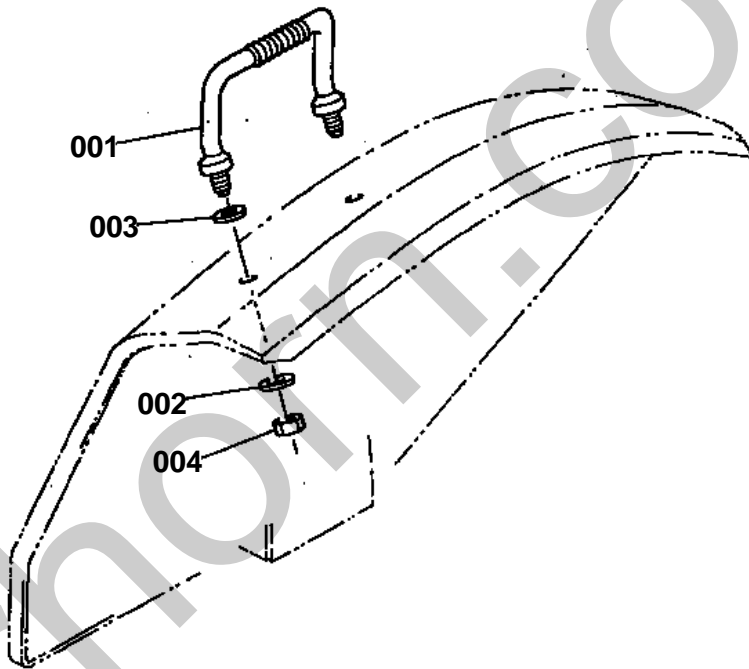

35260-55001
33-01-01



BALUSTRAGE

↔ Interchangeable; ≠ not interchangeable; ← new for old; → old for new

REF.No	Part No.	Description	Q'ty	S.No.	I/C	REMARKS	Weight (kgf)	Weight (lb)
001	35260-29190	RAIL,HAND	2				0.27	0.594
002	04013-50140	WASHER,PLAIN	4				0	0
003	32260-29180	CUSHION	4				0.005	0.011
004	02174-50140	NUT	4				0.014	0.0308

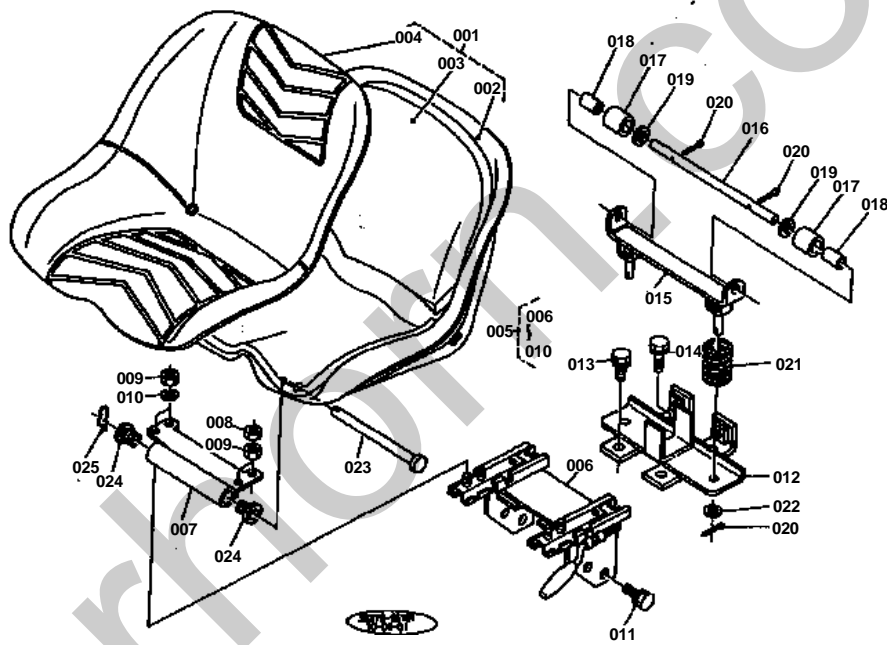

**SEAT**

↔ Interchangeable; ≠ not interchangeable; ← new for old; → old for new

REF.No	Part No.	Description	Q'ty	S.No.	I/C	REMARKS	Weight (kgf)	Weight (lb)
001	35370-85010	ASSY SEAT	1				5.5	12.1
002	99999-99999	BLANK	0			ORDER BY REF.No.001	0	0
003	99999-99999	BLANK	0			ORDER BY REF.No.001	0	0
004	99999-99999	BLANK	0			ORDER BY REF.No.001	0	0
005	35370-18410	ASSY ADJUSTER,SEAT	1				2.65	5.83
006	35370-18420	ADJUSTER,SEAT	1				2.7	5.94
007	35260-18430	SUPPORT,SEAT	1				0.54	1.188
008	02112-50080	NUT	2				0.003	0.0066
009	02114-50080	NUT	4				0.005	0.011
010	04512-50080	WASHER,SPRING	2				0.001	0.0022
011	01133-51020	BOLT	4				0.02	0.044
012	35370-18440	SUPPORT,CUSHION	1				1.29	2.838
013	01133-51020	BOLT	2				0.02	0.044
014	01133-51035	BOLT	2				0.03	0.066
015	35260-18480	BRACKET,CUSHION	1				0.5	1.1
016	35260-18490	SHAFT,CUSHION	1				0.13	0.286
017	38240-18440	CUSHION	2				0.035	0.077
018	35260-18500	COLLAR	2				0.018	0.0396
019	04013-50100	WASHER,PLAIN	2				0	0
020	05511-50315	PIN,SPLIT	4				0.002	0.0044
021	66204-45980	SPRING,SEAT	2				0.1	0.22
022	04012-50080	WASHER,PLAIN	2				0.001	0.0022
023	38240-18470	PIN,SEAT	1				0.085	0.187
024	37150-18490	CUSHION	2				0.014	0.0308
025	05515-51000	PIN,SNAP	1				0	0

S.M.V. EMBLEM BRACKET

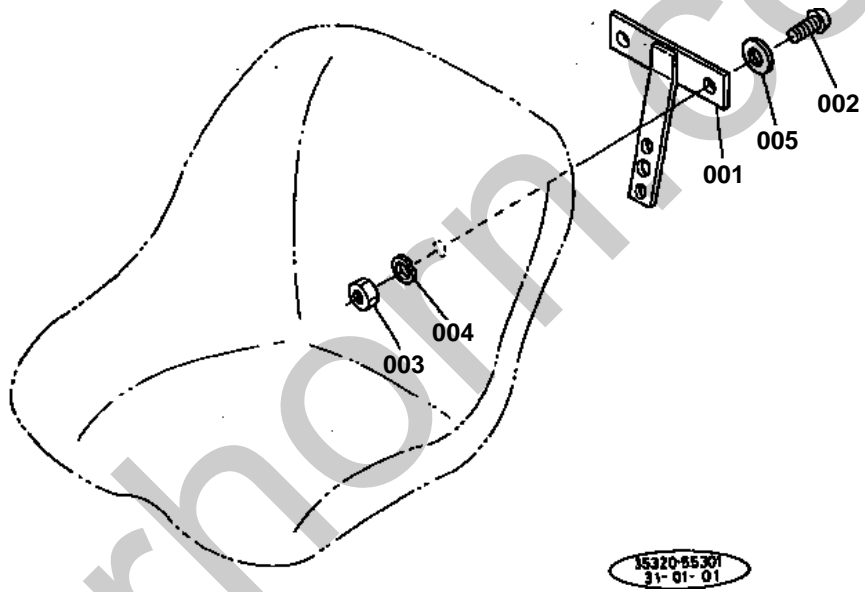

15320-85301
31-01-01



S.M.V.EMBLEM BRACKET

↔ Interchangeable; ≠ not interchangeable; ← new for old; → old for new

REF.No	Part No.	Description	Q'ty	S.No.	I/C	REMARKS	Weight (kgf)	Weight (lb)
001	35320-18480	BRACKET	1				0.22	0.484
002	03014-50616	BOLT	2				0.003	0.0066
003	02014-50060	NUT	2				0.003	0.0066
004	04512-50060	WASHER,SPRING	2				0	0
005	04012-50060	WASHER,PLAIN	2				0.001	0.0022

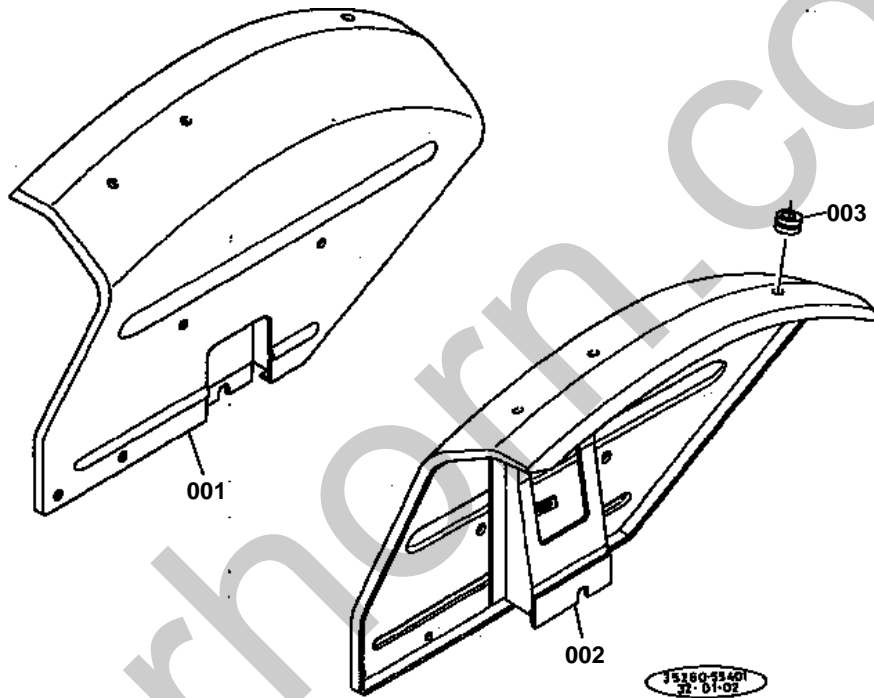



FENDER

↔ Interchangeable; ≠ not interchangeable; ← new for old; → old for new

REF.No	Part No.	Description	Q'ty	S.No.	I/C	REMARKS	Weight (kgf)	Weight (lb)
001	35260-29114	ASSY FENDER RH	1				0	0
002	35260-29123	ASSY FENDER LH	1				6.5	14.3
003	33251-83910	CUSHION	1				0.001	0.0022

Silverhorn.CO.UK

CONTROL VALVE

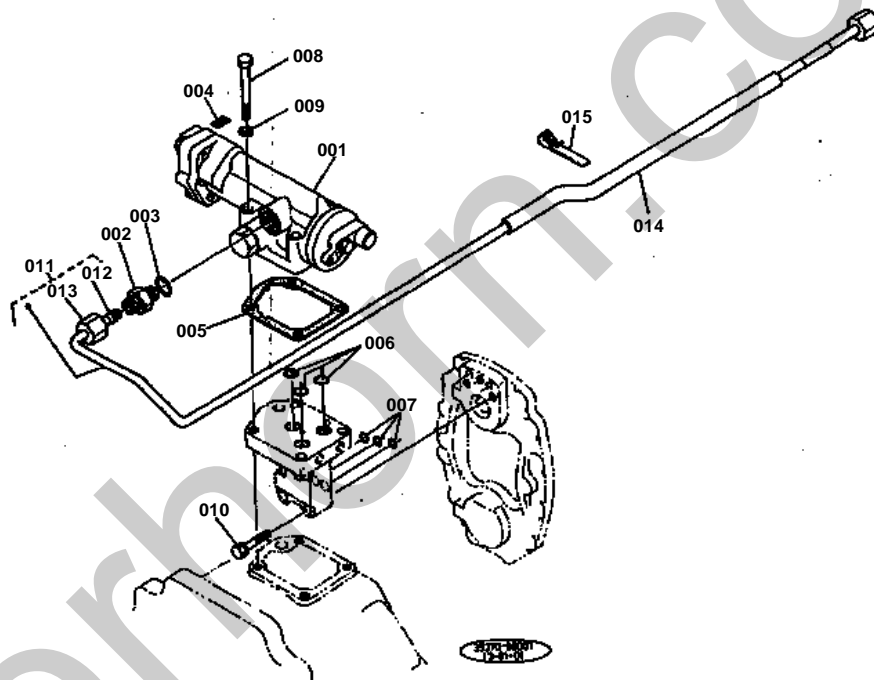



CONTROL VALVE

↔ Interchangeable; ≠ not interchangeable; ← new for old; → old for new

REF.No	Part No.	Description	Q'ty	S.No.	I/C	REMARKS	Weight (kgf)	Weight (lb)
001	35370-46000	VALVE,CONTROL	1				4.7	10.34
002	35270-16790	JOINT,PIPE	1				0.05	0.11
003	04810-00140	O RING	1				0.001	0.0022
004	35370-46370	LABEL,ORIFICE	1				0.001	0.0022
005	35370-46330	PACKING	1				0.004	0.0088
006	04811-00120	O RING	4				0.001	0.0022
007	04811-00090	O RING	3				0.001	0.0022
008	01153-50875	BOLT	4				0.028	0.0616
009	04512-50080	WASHER,SPRING	4				0.001	0.0022
010	01123-50840	BOLT	2				0.018	0.0396
011	35370-46360	COMP PIPE	1				0.34	0.748
012	99999-99999	BLANK	0			ORDER BY REF.No.011	0	0
013	99999-99999	BLANK	0			ORDER BY REF.No.011	0	0
014	35370-46380	HOSE	1				0.06	0.132
015	35370-46390	BAND	3				0.002	0.0044

CONTROL VALVE SECTION PARTS 1

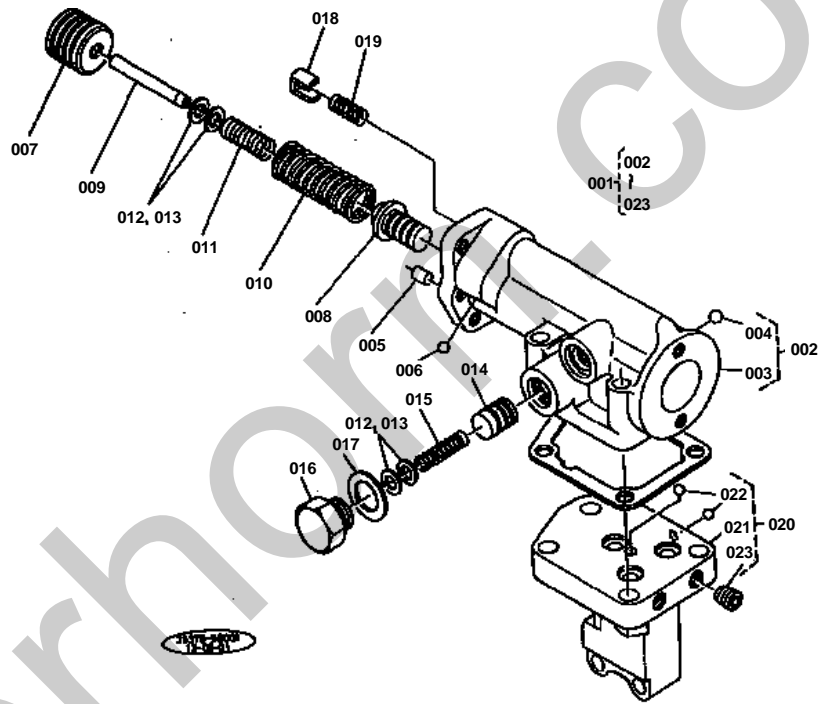



CONTROL VALVE SECTION PARTS 1

↔ Interchangeable; ≠ not interchangeable; ← new for old; → old for new

REF.No	Part No.	Description	Q'ty	S.No.	I/C	REMARKS	Weight (kgf)	Weight (lb)
001	35370-46000	VALVE,CONTROL	1				4.7	10.34
002	35370-46100	ASSY BODY,VALVE	1				3	6.6
003	35370-46110	BODY,VALVE	1				0	0
004	07715-01605	BALL	1				0.003	0.0066
005	05012-00408	PIN,STRAIGHT	2				0.001	0.0022
006	07715-03207	BALL	1				0.001	0.0022
007	35370-46120	PISTON,VALVE	1				0	0
008	35370-46130	VALVE,RELIEF 1	1				0.05	0.11
009	35370-46140	PIN	1				0.01	0.022
010	35370-46150	SPRING	1				0.03	0.066
011	35370-46160	SPRING	1				0.01	0.022
012	35370-46170	SHIM 0.5	3				0.001	0.0022
013	35370-46180	SHIM 1.0	3				0.005	0.011
014	35370-46190	VALVE,RELIEF 2	1				0.02	0.044
015	35370-46200	SPRING	1				0.005	0.011
016	06331-35020	PLUG	1				0.068	0.1496
017	04724-00200	PACKING	1				0.003	0.0066
018	35370-46210	VALVE,CHECK	1				0.005	0.011
019	35370-46220	SPRING	1				0.001	0.0022
020	35370-46500	ASSY SPACE VALVE	1				1.56	3.432
021	35370-46342	SPACE VALVE	1				0	0
022	07715-03207	BALL	2				0.001	0.0022
023	35370-46350	PLUG	3				0.005	0.011

CONTROL VALVE SECTION PARTS 2

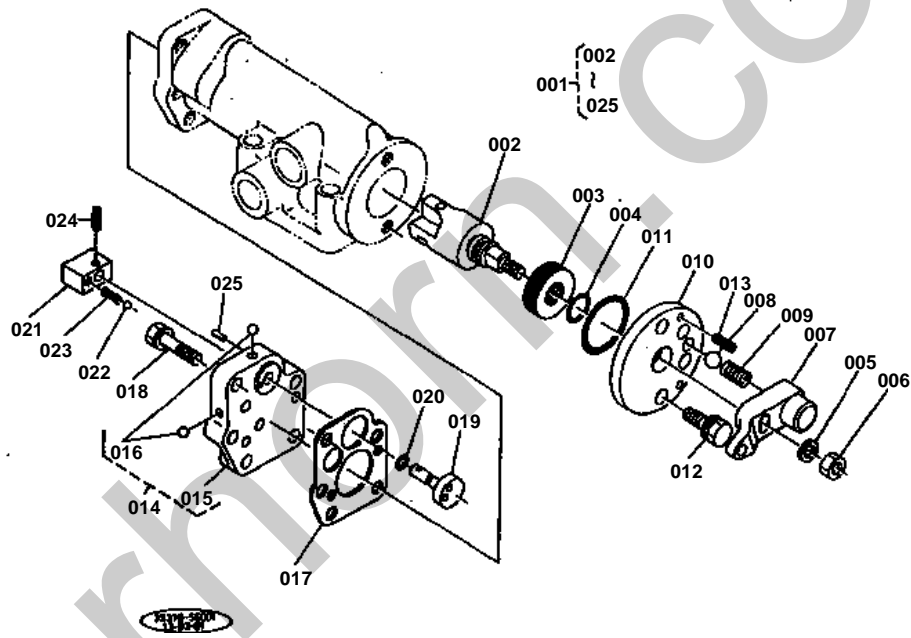



CONTROL VALVE SECTION PARTS 2

↔ Interchangeable; ≠ not interchangeable; ← new for old; → old for new

REF.No	Part No.	Description	Q'ty	S.No.	I/C	REMARKS	Weight (kgf)	Weight (lb)
001	35370-46000	VALVE,CONTROL	1				4.7	10.34
002	35370-46230	SELECTOR	1				0.22	0.484
003	35370-46240	BEARING,THRUST	1				0.013	0.0286
004	04811-00110	O RING	1				0.001	0.0022
005	04512-50080	WASHER,SPRING	1				0.001	0.0022
006	02114-50080	NUT	1				0.005	0.011
007	35370-46250	LEVER,VALVE	1				0.115	0.253
008	07715-00803	BALL	1				0.004	0.0088
009	35370-46260	SPRING	1				0.005	0.011
010	35370-46270	COVER,SELECTOR	1				0.2	0.44
011	04811-16350	O RING	1				0.001	0.0022
012	01123-50825	BOLT	2				0.013	0.0286
013	05411-00414	PIN,SPRING	2				0.001	0.0022
014	35370-46400	ASSY COVER,VALVE	1				0.345	0.759
015	35370-46280	COVER,VALVE	1				0	0
016	07715-03207	BALL	2				0.001	0.0022
017	35370-46290	PACKING	1				0.005	0.011
018	01123-50830	BOLT	5				0.015	0.033
019	35370-46300	ORIFICE,ROTARY	1				0.02	0.044
020	04811-10040	O RING	1				0.001	0.0022
021	35370-46310	LEVER,ORIFICE	1				0.04	0.088
022	07715-00801	BALL	1				0.001	0.0022
023	35370-46320	SPRING	1				0.002	0.0044
024	05411-00216	PIN,SPRING	1				0.001	0.0022
025	05411-00208	PIN,SPRING	1				0.001	0.0022

UPPER MUFFLER

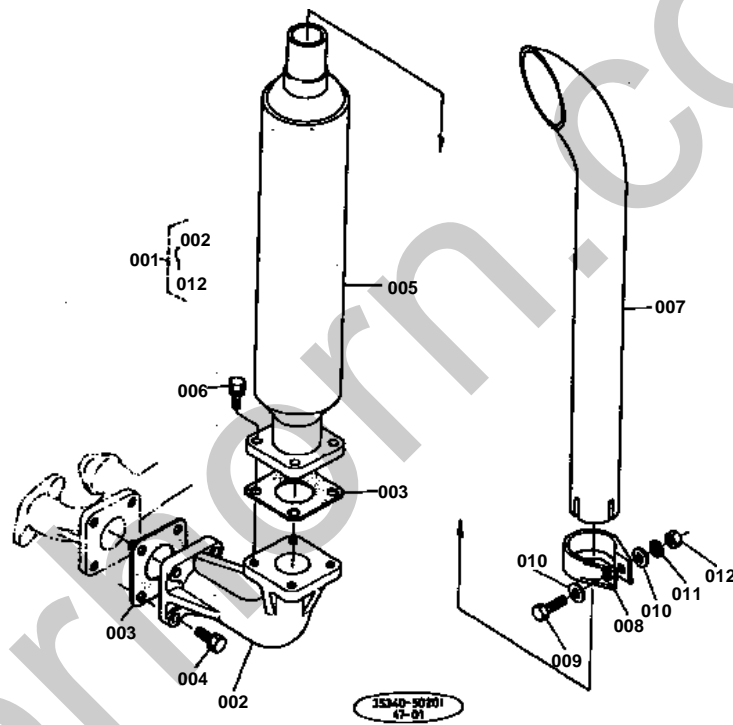



UPPER MUFFLER

↔ Interchangeable; ≠ not interchangeable; ← new for old; → old for new

REF.No	Part No.	Description	Q'ty	S.No.	I/C	REMARKS	Weight (kgf)	Weight (lb)
001	35340-62100	ASSY MUFFLER	1				4.5	9.9
002	15416-12320	FLANGE,MUFFLER	1				1.48	3.256
003	15371-12370	GASKET,M-FLANGE	2				0	0
004	01123-50828	BOLT	4				0.014	0.0308
005	15521-12110	MUFFLER	1				4.7	10.34
006	01123-50825	BOLT	4				0.013	0.0286
007	15416-12410	PIPE,MUFFLER	1				0.73	1.606
008	15416-12130	BAND,MUFFLER	1				0.1	0.22
009	01153-50835	BOLT	1				0.016	0.0352
010	04012-50080	WASHER,PLAIN	2				0.001	0.0022
011	04512-50080	WASHER,SPRING	1				0.001	0.0022
012	02156-50080	NUT	1				0.004	0.0088

TOP LINK HOLDER

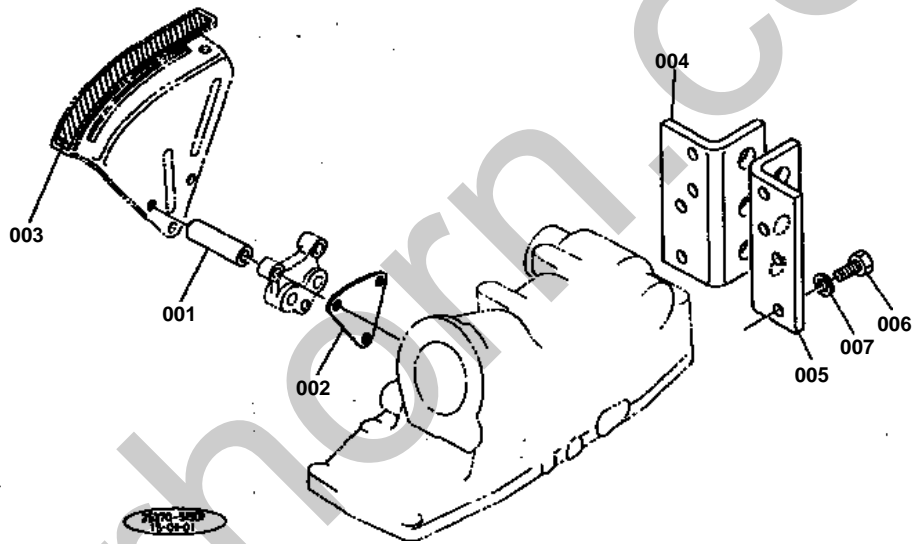



TOP LINK HOLDER

↔ Interchangeable; ≠ not interchangeable; ← new for old; → old for new

REF.No	Part No.	Description	Q'ty	S.No.	I/C	REMARKS	Weight (kgf)	Weight (lb)
001	35300-36870	COLLAR	3				0.069	0.1518
002	34260-37160	PLATE	1				0.04	0.088
003	35300-36980	MARK,CONTROL	1				0.01	0.022
004	37267-71140	HOLDER,TOP LINK RH	1				1.15	2.53
005	37267-71150	HOLDER,TOP LINK LH	1				1.155	2.541
006	01173-51228	BOLT	8				0.036	0.0792
007	04512-50120	WASHER,SPRING	8				0	0

DRAFT CONTROL VALVE

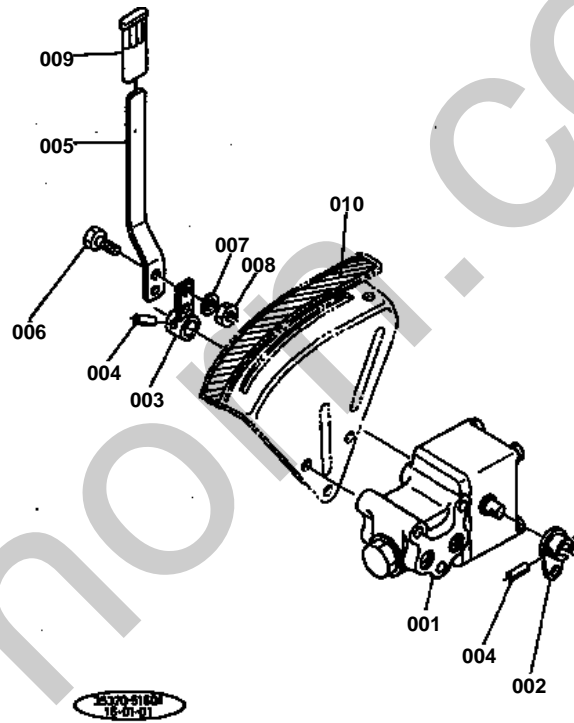



DRAFT CONTROL VALVE

↔ Interchangeable; ≠ not interchangeable; ← new for old; → old for new

REF.No	Part No.	Description	Q'ty	S.No.	I/C	REMARKS	Weight (kgf)	Weight (lb)
001	37300-41100	ASSY VALVE,DRAFT CON	1				3.2	7.04
002	37300-41190	LEVER,FEED BACK	1				0.056	0.1232
003	37300-41220	LEVER,DRAFT CONTROL	1				0.042	0.0924
004	05411-00525	PIN,SPRING	2				0.002	0.0044
005	35212-41230	LEVER,DRAFT CONTROL	1				0.14	0.308
006	01053-50616	BOLT	2				0.005	0.011
007	04512-50060	WASHER,SPRING	2				0	0
008	02056-50060	NUT	2				0.002	0.0044
009	34350-36890	GRIP,LEVER	1				0.016	0.0352
010	35212-36980	LABEL,CONTROL	1				0.005	0.011

DRAFT CONTROL VALVE SECTION PARTS

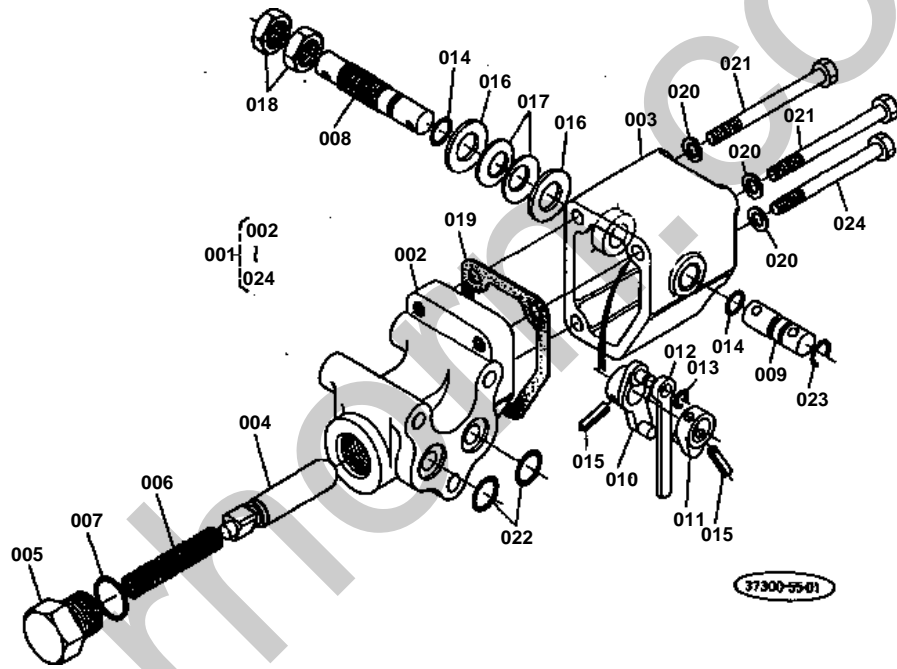



DRAFT CONTROL VALVE SECTION PARTS

↔ Interchangeable; ≠ not interchangeable; ← new for old; → old for new

REF.No	Part No.	Description	Q'ty	S.No.	I/C	REMARKS	Weight (kgf)	Weight (lb)
001	37300-41100	ASSY VALVE,DRAFT CON	1				3.2	7.04
002	99999-99999	BLANK	0			ORDER BY REF.No.001	0	0
003	37300-41120	CAP	1				1.05	2.31
004	99999-99999	BLANK	0			ORDER BY REF.No.001	0	0
005	37300-41140	PLUG	1				0.098	0.2156
006	37300-41150	SPRING	1				0.01	0.022
007	04811-00180	O RING	1				0.001	0.0022
008	37300-41160	SHAFT	1				0.065	0.143
009	37300-41170	SHAFT	1				0.03	0.066
010	37300-41180	ARM	1				0.03	0.066
011	32240-36630	ARM	1				0.015	0.033
012	37300-41270	LINK	1				0.012	0.0264
013	04613-50050	RING,SNAP	1				0.001	0.0022
014	04811-00090	O RING	2				0.001	0.0022
015	05411-00518	PIN,SPRING	2				0.002	0.0044
016	04011-50140	WASHER,PLAIN	2				0.007	0.0154
017	37300-41280	WASHER,SPRING	2				0.005	0.011
018	02172-50140	NUT	2				0.01	0.022
019	37300-41290	GASKET	1				0.001	0.0022
020	04512-50080	WASHER,SPRING	3				0.001	0.0022
021	01150-50875	BOLT	2				0	0
022	04810-00160	O RING	2				0.001	0.0022
023	37300-41360	RING,SNAP	1				0.001	0.0022
024	01150-50870	BOLT	1				0	0

TOP LINK BRACKET

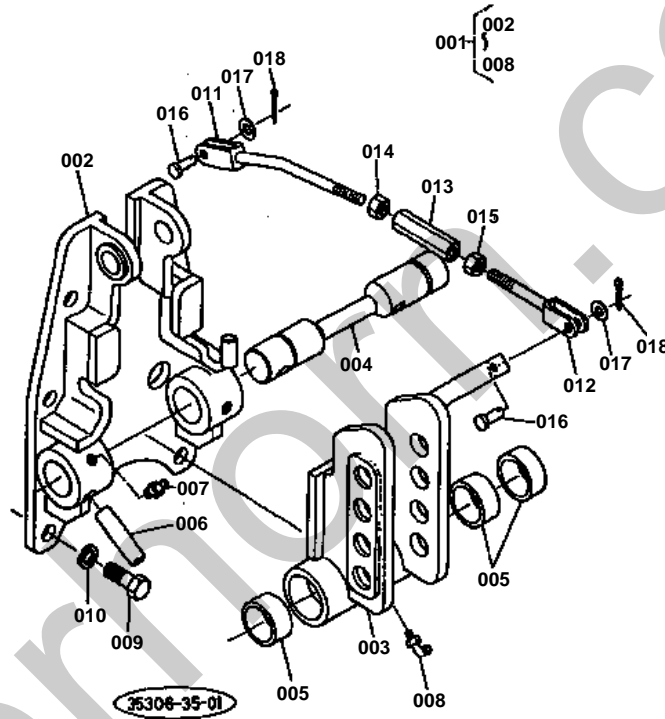



TOP LINK BRACKET

↔ Interchangeable; ≠ not interchangeable; ← new for old; → old for new

REF.No	Part No.	Description	Q'ty	S.No.	I/C	REMARKS	Weight (kgf)	Weight (lb)
001	35300-41400	ASSY BRACKET, TOP LIN	1				0	0
002	99999-99999	BLANK	0			ORDER BY REF.No.001	0	0
003	99999-99999	BLANK	0			ORDER BY REF.No.001	0	0
004	99999-99999	BLANK	0			ORDER BY REF.No.001	0	0
005	37300-41450	BUSH	3				0.03	0.066
006	99999-99999	BLANK	0			ORDER BY REF.No.001	0	0
007	06613-10010	NIPPLE, GREASE	1				0.006	0.0132
008	06613-20010	NIPPLE, GREASE	2				0.01	0.022
009	01173-51228	BOLT	6				0.036	0.0792
010	04512-50120	WASHER, SPRING	6				0	0
011	37300-41310	ROD, DRAFT CONTROL	1				0.07	0.154
012	37300-41320	ROD, DRAFT CONTROL	1				0.04	0.088
013	66591-42410	TURNBUCKLE	1				0.046	0.1012
014	02114-50080	NUT	1				0.005	0.011
015	37300-41330	NUT	1				0.005	0.011
016	05122-50818	PIN, JOINT	2				0.008	0.0176
017	04012-50080	WASHER, PLAIN	2				0.001	0.0022
018	05511-50218	PIN, SPLIT	2				0.001	0.0022

VALVE, FLOW PRIORITY

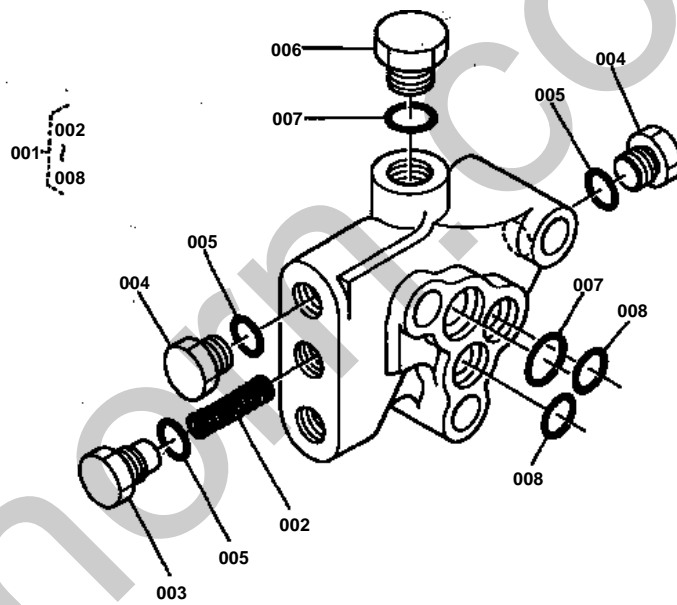

35370-50000
02-43-01

**VALVE, FLOW PRIORITY**

↔ Interchangeable; ≠ not interchangeable; ← new for old; → old for new

REF.No	Part No.	Description	Q'ty	S.No.	I/C	REMARKS	Weight (kgf)	Weight (lb)
001	35370-16710	VALVE, FLOW PRIORITY	1				2.1	4.62
002	35370-67120	SPRING	1				0.007	0.0154
003	35370-67130	PLUG	1				0.04	0.088
004	35370-67140	PLUG	1				0.03	0.066
005	04810-00140	O RING	1				0.001	0.0022
006	35370-67150	PLUG	1				0.135	0.297
007	04810-00160	O RING	2				0.001	0.0022
008	04810-00120	O RING	2				0.001	0.0022

INTEGRAL TYPE POWER STEERING

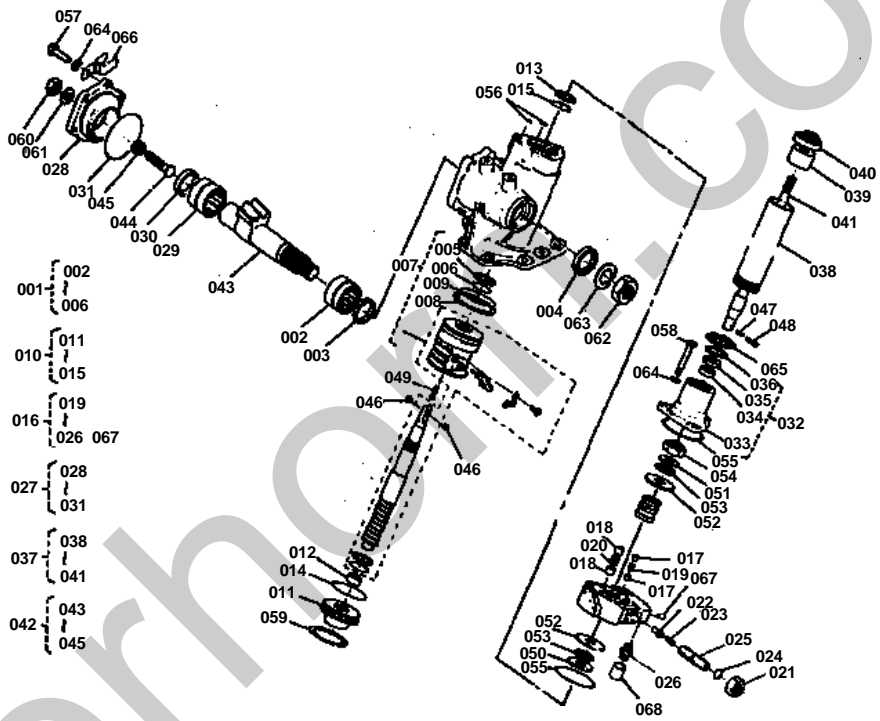



INTEGRAL TYPE POWER STEERING

↔ Interchangeable; ≠ not interchangeable; ← new for old; → old for new

REF.No	Part No.	Description	Q'ty	S.No.	I/C	REMARKS	Weight (kgf)	Weight (lb)
001	35350-16160	ASSY BOX,GEAR	1				7	15.4
002	38430-66120	BEARING,NEEDLE	1				0.195	0.429
003	38430-66130	U PACKING	1				0.005	0.011
004	38430-66140	SEAL,OIL	1				0.02	0.044
005	38430-66150	RING	1				0.002	0.0044
006	04811-10340	O RING	1				0.001	0.0022
007	35350-16200	ASSY BALL NUT	1				3	6.6
008	38430-66220	RING	1				0.005	0.011
009	04811-50600	O RING	1				0.002	0.0044
010	35350-16270	ASSY COVER,FRONT	1				0.34	0.748
011	38430-66250	COVER,FRONT	1				0.34	0.748
012	38430-66260	BEARING,NEEDLE	1				0.015	0.033
013	38430-66150	RING	1				0.002	0.0044
014	04811-50650	O RING	1				0.002	0.0044
015	04811-10340	O RING	1				0.001	0.0022
016	35350-66300	ASSY VALVE	1				2	4.4
017	38430-66320	PISTON 1	4				0.01	0.022
018	38430-66330	PISTON 2	4				0.005	0.011
019	38430-66340	SPRING	2				0.01	0.022
020	38430-66350	SPRING	2				0.003	0.0066
021	38430-66360	PLUG	1				0.03	0.066
022	38430-66370	POPET	1				0.01	0.022
023	38430-66380	SPRING	1				0.015	0.033
024	04811-00180	O RING	1				0.001	0.0022
025	38430-66390	SHIM	1				0.04	0.088
026	38430-45230	NIPPLE	2				0.04	0.088
027	35350-16600	ASSY COVER,SIDE	1				1.365	3.003
028	38430-66470	COVER,SIDE	1				1.22	2.684
029	38430-66480	BEARING,NEEDLE	1				0.12	0.264
030	38430-66130	U PACKING	1				0.005	0.011
031	04811-50800	O RING	1				0.003	0.0066
032	35350-16400	ASSY COVER,REAR	1				1.4	3.08
033	38430-66420	COVER,REAR	1				0.81	1.782
034	38430-66440	BEARING,NEEDLE	1				0.015	0.033
035	38430-66450	SEAL,OIL	1				0.01	0.022
036	04611-00320	CIR-CLIP,EXTERNAL	1				0.002	0.0044
037	35350-16510	ASSY COLUMN	1				0	0
038	38430-66510	COLUMN	1				0.89	1.958
039	38240-16520	BUSH	1				0.04	0.088
040	38240-16390	SEAL,OIL	1				0.03	0.066
041	38430-66520	ASSY SHAFT,STEERING	1				0.57	1.254
042	35350-16700	ASSY SHAFT,SECTOR	1				2.09	4.598
043	35350-66710	SHAFT,SECTOR	1				2.1	4.62
044	38430-66750	SCREW,ADJUSTING	1				0.07	0.154
045	38430-66760	ADJUSTOR	1				0.015	0.033
046	38240-16530	O RING	2				0.001	0.0022
047	05411-00518	PIN,SPRING	1				0.002	0.0044
048	35350-66820	RIVET	1				0.003	0.0066
049	38240-16490	SPRING	1				0.005	0.011
050	38430-66610	RING,DRIVE	1				0.05	0.11
051	38430-66620	RING,DRIVE	1				0.02	0.044
052	38430-66630	RING,DRIVE	2				0.06	0.132
053	38430-66640	BEARING,NEEDLE	2				0.01	0.022
054	38430-66650	NUT	1				0.065	0.143
055	04811-10700	O RING	2				0.001	0.0022



INTEGRAL TYPE POWER STEERING

↔ Interchangeable; ≠ not interchangeable; ← new for old; → old for new

REF.No	Part No.	Description	Q'ty	S.No.	I/C	REMARKS	Weight (kgf)	Weight (lb)
056	04811-00080	O RING	2				0.001	0.0022
057	01173-51028	BOLT	6				0.022	0.0484
058	38430-66660	BOLT	3				0.05	0.11
059	04611-00720	CIR-CLIP,EXTERNAL	1				0.018	0.0396
060	38430-66770	NUT	1				0.02	0.044
061	38430-66780	GASKET	1				0.001	0.0022
062	38430-66720	NUT	1				0.145	0.319
063	38430-66730	WASHER,SPRING	1				0.05	0.11
064	04512-50100	WASHER,SPRING	9				0	0
065	38430-66740	NUT	1				0.02	0.044
066	35350-16780	CLIP	1				0.018	0.0396
067	38430-66790	PLUG	2				0.003	0.0066
068	38430-66800	PLUG,LAPPING	2				0.01	0.022